

UNOPIU'

Outdoor
— 2026

UNOPIU'

Content Index



Collections - Index	5
Products - Index	7
Company	15
Designers	17
Materials & Sustainability	18
Metal Collections	21
Wooden Collections	105
Fibre Collections	197
Sunshades	221
Complements	279
Fabrics	305
Furnishings - Technical Sheets	319
Sunshades - Technical Sheets	379
Complements - Technical Sheets	425
Materials - Maintenance	439

Collections



Salò
p. 23



Igea
p. 35



Pertre
p. 43



Davos
p. 47



Treble
p. 55



Lulù
p. 63



Toscana
p. 65



Aurora
p. 73



Luce
p. 81



Ariete
p. 95



Panarea
p. 99



Fresbee
p. 103



Cora
p. 107



Versilia
p. 115



Synthesis
p. 119



Ginger
p. 133



Amanda
p. 139



Chelsea
p. 143



Welcome
p. 153



Pevero
p. 161



Swing
p. 165



Clio
p. 171



Emy
p. 175



Titanic
p. 177



William
p. 181



C'est La Vie
p. 183



Cosette
p. 191



Agorà
p. 199



Experience
p. 205



Nacre
p. 211































Olimpia
p. 213



































Capri
p. 217

Collections

				
Meridienne p. 223	Shibuya p. 227	Tibisco p. 233	Solaire p. 239	Lipari p. 245
				
Salento p. 249	Damian p. 253	Orangerie p. 255	Manta p. 259	Nagi p. 263
				
Levante p. 267	Riviera p. 269	Covercar p. 271	Dafne p. 275	Aurora p. 76
				
Chelsea p. 150	Egadi p. 281	Symi p. 283	Syros p. 285	Pouf p. 287
				
Rugs p. 289	Vases p. 293	Portofino p. 295	Solare p. 297	Jolly Cushions p. 301
				
Iron Panels p. 417	Wooden Panels p. 393	Iron Planters p. 416	Wooden Flower Pots p. 400	

Products

Sofas

				
Salò p. 23	Igea p. 35	Davos p. 47		
				
Treble p. 55	Toscana p. 65	Aurora p. 73	Luce p. 81	Ariete p. 95
				
Cora p. 107	Synthesis p. 119	Chelsea p. 143	Welcome p. 153	C'est La Vie p. 183
				
Agorà p. 199	Experience p. 205	Olimpia p. 213		
				
	Igea p. 35	Salò p. 23	Salò p. 23	
				
Toscana p. 65	Aurora p. 73	Luce p. 81	Cora p. 107	Synthesis p. 119
				
Ginger p. 133	Chelsea p. 143	Pevero p. 161	William p. 181	Cosette p. 191
				
Experience p. 205	Experience p. 205	Capri p. 217		

Chairs Small armchairs

Products

Armchairs



Salò
p. 23



Igea
p. 35



Davos
p. 47



Treble
p. 55



Lulù
p. 63



Toscana
p. 65



Aurora
p. 73



Luce
p. 81



Ariete
p. 95



Cora
p. 107



Synthesis
p. 119



Synthesis
p. 119



Chelsea
p. 143



Chelsea
p. 143



Welcome
p. 153



Emy
p. 175



C'est La Vie
p. 183



Agorà
p. 199



Experience
p. 205



Nacre
p. 211



Olimpia
p. 213

Stools



Salò
p. 23



Salò
p. 23



Luce
p. 81



Swing
p. 165



Egadi
p. 281

Products

Tables



Salò
p. 23



Salò
p. 23



Salò
p. 23



Igea
p. 35



Igea
p. 35



Pertre
p. 43



Pertre
p. 43



Pertre
p. 43



Pertre
p. 43



Aurora
p. 73



Luce
p. 81



Luce
p. 81



Cora
p. 107



Versilia
p. 115



Versilia
p. 115



Synthesis
p. 119



Synthesis
p. 119



Synthesis
p. 119



Synthesis
p. 119



Chelsea
p. 143



Chelsea
p. 143



Chelsea
p. 143



C'est La Vie
p. 183



C'est La Vie
p. 183



Cosette
p. 191



Experience
p. 205

High Tables



Salò
p. 23



Pertre
p. 43



Pertre
p. 43



Pertre
p. 43



Pertre
p. 43



Luce
p. 81



Luce
p. 81

Products

Coffee tables



Salò
p. 23



Salò
p. 23



Salò
p. 23



Igea
p. 35



Igea
p. 35



Igea
p. 35



Davos
p. 47



Davos
p. 47



Treble
p. 55



Luce
p. 81



Luce
p. 81



Ariete
p. 95



Panarea
p. 99



Feesbee
p. 103



Feesbee
p. 103



Synthesis
p. 119



Synthesis
p. 119



Synthesis
p. 119



Synthesis
p. 119



Chelsea
p. 143



Chelsea
p. 143



Welcome
p. 153



Welcome
p. 153



C'est La Vie
p. 183



Agorà
p. 199



Experience
p. 205



Olimpia
p. 213



Egadi
p. 281



Symi
p. 283



Symi
p. 283



Syros
p. 285

Products

Sunloungers Chaise longues



Salò
p. 23



Igea
p. 35



Igea
p. 35



Davos
p. 47



Aurora
p. 73



Luce
p. 81



Luce
p. 81



Panarea
p. 99



Cora
p. 107



Cora
p. 107



Cora
p. 107



Synthesis
p. 119



Synthesis
p. 119



Synthesis
p. 119



Synthesis
p. 119



Synthesis
p. 119



Amanda
p. 139



Chelsea
p. 143



Swing
p. 165



Clio
p. 171



Titanic
p. 177



C'est La Vie
p. 183



C'est La Vie
p. 183



Cosette
p. 191



Agorà
p. 199



Agorà
p. 199

Products

Sunshades



Meridienne
p. 223

Shibuya
p. 227

Tibisco
p. 233



Tibisco
p. 233

Solaire
p. 233

Solaire
p. 239

Lipari
p. 245

Salento
p. 249



Salento
p. 249

Damian
p. 253

Orangerie
p. 255

Orangerie
p. 255

Manta
p. 259



Nagi
p. 263

Levante
p. 267

Riviera
p. 269

Covercar
p. 271

Dafne
p. 275

Lightings and Complements



Aurora
p. 76

Chelsea
p. 137

Pouf
p. 277



Rugs
p. 279

Vases
p. 283

Portofino
p. 285

Solare
p. 285

Jolly Cushions
p. 291



Iron Panels
p. 297

Wooden Panels
p. 403

Iron Planters
p. 380

Wooden Flower Pots
p. 402

Egadi
p. 281



Symi
p. 283

Symi
p. 283

Syros
p. 285



En -

Unopiù, a leader in the production of outdoor furniture and accessories, was founded in Italy in 1978 ago with the idea of creating "an extra room," a space dedicated to the outdoors.

The company's mission is to furnish outdoor spaces with the same care and passion as interiors, offering elegant, functional, and weather-resistant solutions. Unopiù provides a "total look" for terraces, gardens, resorts, hotels, and yachts, with products made to last over time thanks to superior-quality materials. The company is a reference point in the world of outdoor design, creating spaces that combine comfort, well-being, and style. In 1978, Unopiù was the first brand to design furniture exclusively for outdoor use, becoming an internationally recognized brand for its timeless, customized solutions. Some of its most notable projects include terraces and outdoor spaces at Bulgari Hotel, Four Seasons Resort, Hilton, W Hotel, and many others.

With ten monobrand stores, including in Milan and Paris, Unopiù continues to be a global leader in the outdoor design sector.

It -

Unopiù, leader nella produzione di arredi e accessori di design per esterni, nasce in Italia nel 1978 fa con l'idea di creare "una stanza in più", uno spazio dedicato all'outdoor.

L'azienda ha come missione arredare gli spazi esterni con la stessa cura e passione degli interni, offrendo soluzioni eleganti, funzionali e resistenti agli agenti atmosferici. Unopiù propone un "total look" per terrazze, giardini, resort, hotel e yacht, con prodotti realizzati per durare nel tempo, grazie a materiali di qualità superiore. L'azienda è un punto di riferimento nel mondo dell'outdoor, arredando spazi che uniscono comfort, benessere e design. Nel 1978, Unopiù è stato il primo brand a progettare arredi esclusivamente per l'outdoor fino a diventare un brand riconosciuto a livello internazionale per le sue soluzioni personalizzate e senza tempo. Tra i progetti più noti si annoverano terrazze e spazi esterni di Bulgari Hotel, Four Seasons Resort, Hilton, W Hotel, e molti altri.

Con dieci negozi monomarca, tra cui a Milano e Parigi, Unopiù continua ad essere un protagonista globale nel settore del design outdoor.

Fr -

Unopiù, leader dans la production de mobilier et d'accessoires de design pour l'extérieur, a été fondée en Italie en 1978 avec l'idée de créer "une pièce en plus", un espace dédié à l'outdoor.

L'entreprise a pour mission d'aménager les espaces extérieurs avec la même attention et passion que pour les intérieurs, en offrant des solutions élégantes, fonctionnelles et résistantes aux intempéries. Unopiù propose un "total look" pour terrasses, jardins, resorts, hôtels et yachts, avec des produits conçus pour durer dans le temps grâce à des matériaux de qualité supérieure. L'entreprise est un point de référence dans le monde de l'outdoor, aménageant des espaces alliant confort, bien-être et design. En 1978, Unopiù a été la première marque à concevoir du mobilier exclusivement pour l'extérieur, devenant ainsi une marque reconnue à l'international pour ses solutions personnalisées et intemporelles. Parmi les projets les plus connus figurent les terrasses et espaces extérieurs du Bulgari Hotel, du Four Seasons Resort, du Hilton, du W Hotel et bien d'autres.

Avec dix magasins monomarkets, dont à Milan et à Paris, Unopiù continue d'être un acteur mondial dans le secteur du design extérieur.

Designers



Federica Biasi
Andreucci & Hoisl
Michele Bönan
Daniel Jarefeldt
Ferruccio Laviani
Matteo Nunziati
Keiji Takeuchi
Matteo Thun
& Benedetto Fasciana
Andrea Steidl
Adam D. Tihany
Gianpaolo Venier
Zaven Studio

En -

Unopiù projects its vision of the outdoors through the eyes of designers that, inspired by traditions, give form to the Company's values creating signature products that embody the quality and unique style of Unopiù.

It -

Unopiù interpreta la visione dello stile outdoor attraverso lo sguardo dei designer che, ispirati dalla tradizione, hanno tradotto i valori dell'azienda firmando prodotti capaci di raccontare la qualità e lo stile unico di Unopiù.

Fr -

Unopiù interprète la vision du style outdoor à travers le regard des designers qui, inspirés par la tradition, ont traduit les valeurs de l'entreprise en signant des produits capables de raconter la qualité et le style unique d'Unopiù.

Materials & Sustainability

En -

Unopiù combines the pursuit of excellence and innovation with a constant commitment to sustainability, starting with the responsible selection of raw materials. Each piece of furniture is designed to last, maintaining a timeless appeal thanks to conscious production choices that ensure its longevity.

The teak used, grade A, comes from Indonesian plantations managed by the government in an eco-sustainable manner, with strict reforestation processes. This commitment has allowed Unopiù to obtain FSC (Forest Stewardship Council) certification, ensuring responsible sourcing.

Aluminum, chosen for its strength and infinite recyclability, also contributes to a sustainable production cycle, allowing the material to continually regain new aesthetic and functional value.

Every Unopiù product is designed to withstand the test of time, with elegant and harmonious forms, in full respect of the environment. The furniture is created to last a lifetime, never compromising the commitment to sustainability.

It -

Unopiù unisce ricerca dell'eccellenza e innovazione con un impegno costante per la sostenibilità, partendo dalla selezione responsabile delle materie prime. Ogni arredo è progettato per durare, mantenendo un fascino senza tempo grazie a scelte produttive consapevoli che ne garantiscono la longevità.

Il teak utilizzato, di grado A, proviene da piantagioni indonesiane gestite dal governo in modo eco-sostenibile, con rigorosi processi di riforestazione. Questo impegno ha permesso a Unopiù di ottenere la certificazione FSC (Forest Stewardship Council), che garantisce un approvvigionamento responsabile.

L'alluminio, scelto per la sua resistenza e riciclabilità infinita, contribuisce anch'esso a un ciclo produttivo sostenibile, permettendo al materiale di riacquistare sempre nuovo valore estetico e funzionale.

Ogni prodotto Unopiù è pensato per resistere nel tempo, con forme eleganti e armoniose, nel massimo rispetto dell'ambiente. Gli arredi sono progettati per durare tutta la vita, senza mai compromettere l'impegno verso la sostenibilità.

Fr -

Unopiù allie la recherche de l'excellence et l'innovation avec un engagement constant en faveur de la durabilité, en commençant par la sélection responsable des matières premières. Chaque meuble est conçu pour durer, en conservant un charme intemporel grâce à des choix de production conscients qui en garantissent la longévité.

Le teck utilisé, de grade A, provient de plantations indonésiennes gérées de manière éco-durable par le gouvernement, avec des processus rigoureux de reforestation. Cet engagement a permis à Unopiù d'obtenir la certification FSC (Forest Stewardship Council), garantissant un approvisionnement responsable.

L'aluminium, choisi pour sa résistance et sa recyclabilité infinie, contribue également à un cycle de production durable, permettant au matériau de retrouver toujours une nouvelle valeur esthétique et fonctionnelle.

Chaque produit Unopiù est conçu pour résister dans le temps, avec des formes élégantes et harmonieuses, dans le plus grand respect de l'environnement. Les meubles sont conçus pour durer toute une vie, sans jamais compromettre l'engagement envers la durabilité.



Metal Collections

01.

Igea
Salò
Davos
Treble
Lulú
Toscana
Aurora
Luce
Ariete
Panarea
Conrad
Fresbee

Salò Collection

Design by
Matteo Thun
& Benedetto Fasciana



En

Essential, elegant, and designed to stand the test of time, the Salò collection, created by Matteo Thun and Benedetto Fasciana, expands this year with new pieces tailored to the world of bistros. The existing line is now joined by high tables and stools, available with or without backrests, further broadening its range of uses and making the collection even more complete and versatile. With a clean and functional aesthetic, Salò perfectly meets the needs of contemporary hospitality, offering coordinated solutions for both indoor and outdoor spaces that strike a balance between form, comfort, and durability.

It

Essenziale, elegante e pensata per durare nel tempo, la collezione Salò, firmata da Matteo Thun e Benedetto Fasciana, si arricchisce quest'anno di nuove proposte pensate per il mondo bistro. Alla linea già esistente si aggiungono infatti tavoli alti e sgabelli, disponibili con o senza schienale, ampliando ulteriormente le possibilità di utilizzo e rendendo la collezione ancora più completa e versatile. Con un'estetica sobria e funzionale, Salò risponde perfettamente alle esigenze dell'hospitality contemporanea, offrendo soluzioni coordinate per ambienti indoor e outdoor all'insegna dell'equilibrio tra forma, comfort e resistenza.

Fr

Essentielle, élégante et conçue pour durer dans le temps, la collection Salò, signée par Matteo Thun et Benedetto Fasciana, s'enrichit cette année de nouvelles propositions pensées pour l'univers des bistros. À la ligne déjà existante s'ajoutent en effet des tables hautes et des tabourets, disponibles avec ou sans dossier, élargissant encore les possibilités d'utilisation et rendant la collection encore plus complète et polyvalente. Avec une esthétique sobre et fonctionnelle, Salò répond parfaitement aux exigences de l'hospitalité contemporaine, en offrant des solutions coordonnées pour les espaces intérieurs et extérieurs, alliant forme, confort et résistance.



En -

Its aluminum structure, lightweight and durable, is ideal for adapting to various climatic conditions, from the saltiness of the sea to the colder temperatures of the mountains, maintaining its elegance and functionality in any setting.

It -

La sua struttura in alluminio, leggera e resistente, è ideale per adattarsi a diverse condizioni climatiche, dalla salsedine del mare alle temperature più rigide in montagna, mantenendo intatta la sua eleganza e funzionalità in ogni scenario.

Fr -

Sa structure en aluminium, légère et résistante, est idéale pour s'adapter à diverses conditions climatiques, de la salinité de la mer aux températures plus froides des montagnes, tout en préservant son élégance et sa fonctionnalité dans tous les environnements.







En -

Salò collection becomes more than furniture: It's a place for quiet moments, long lunches, and meaningful connections. A space to gather, to share beauty – of the view, the moment, and being together.

It -

Salò è molto più di un arredo: è un luogo in cui vivere momenti di quiete, lunghi pranzi e connessioni autentiche. Uno spazio in cui ritrovarsi e condividere la bellezza – del paesaggio, dell'attimo, dello stare insieme.

Fr -

La collection Salò est bien plus qu'un simple meuble : c'est un lieu pour savourer le calme, prolonger les repas et créer des liens sincères. Un espace pour se retrouver, partager la beauté – du paysage, de l'instant, de la convivialité.





Igea Collection

Design by
Matteo Thun
& Benedetto Fasciana



En -

Imagine starring in an episode of successful The White Lotus series, surrounded by outstanding Sicilian architecture, or sitting with The Leopard - Don Fabrizio Corbera for a drink on one of the most beautiful terraces in Taormina, Noto or Ortigia. The classic IGEA outdoor furniture collection, with its powder coated galvanized iron structure and elegant proportions, embodies the 'dolce vita' and brings the dream of Sicily to your outdoor space.

It -

Immagina di essere protagonista di un episodio della fortunata serie The White Lotus, circondato dalla straordinaria architettura siciliana, oppure di sorseggiare un drink con Il Gattopardo - Don Fabrizio Corbera - su una delle terrazze più belle di Taormina, Noto o Ortigia. La collezione di arredi da esterno classici IGEA, con la sua struttura in ferro e le proporzioni eleganti, incarna la dolce vita e porta il sogno della Sicilia nel tuo spazio all'aperto.

Fr -

Imaginez-vous dans un épisode de la célèbre série The White Lotus, entouré d'une architecture sicilienne exceptionnelle, ou en train de prendre un verre avec Le Guépard - Don Fabrizio Corbera - sur l'une des plus belles terrasses de Taormine, Noto ou Ortigia. La collection de mobilier d'extérieur classique IGEA, avec sa structure en fer galvanisé thermolaqué et ses proportions élégantes, incarne la dolce vita et apporte le rêve de la Sicile dans votre espace extérieur.



En -

The collection includes everything you need to create the perfect Mediterranean atmosphere. There are dining chairs, some of which are foldable. The graphite frame can be complemented with matching cushions featuring classic stripes. Generous and comfortable armchairs and two- or three-seat sofas can be flanked by two types of dining table and coffee tables.

It -

La collezione include tutto il necessario per ricreare la perfetta atmosfera mediterranea. Ci sono sedie da pranzo, alcune delle quali pieghevoli. La struttura in grafite può essere completata da cuscini coordinati con classiche righe. Ampie e comode poltrone e divani a due o tre posti possono essere affiancati da due tipologie di tavoli da pranzo e tavolini.

Fr -

La collection comprend tout ce qu'il faut pour créer une atmosphère méditerranéenne parfaite. Il y a des chaises de salle à manger, dont certaines sont pliantes. La structure graphite peut être complétée par des coussins assortis à rayures classiques. De généreux fauteuils confortables et des canapés deux ou trois places peuvent être accompagnés de deux types de tables à manger et de tables basses.



En -

IGEA, being an homage to the ancient Greek goddess of health and well-being as well, is accompanied with poufs, sun loungers and inviting cabanas completing the ideal setup for enjoying the typical Sicilian vibe.

It -

IGEA, che rende omaggio anche all'antica dea greca della salute e del benessere, è completata da pouf, lettini prendisole e accoglienti cabane, per un allestimento ideale che invita a vivere la tipica atmosfera siciliana.

Fr -

IGEA, en tant qu'hommage à la déesse grecque antique de la santé et du bien-être, est aussi accompagnée de poufs, de bains de soleil et de cabanes accueillantes, complétant ainsi l'agencement idéal pour profiter de l'ambiance typique sicilienne.



Pertre Collection

Design by
Zaven Studio



En -

Designed by the Zaven studio, the Pertre collection was created to meet the needs of contemporary hospitality, offering versatile solutions that combine functionality with aesthetic identity. The tables, available in round or square versions, easily adapt to a variety of contexts and layouts. The distinctive triangular leg adds character to the structure, while the bases – made of steel or concrete – can be paired with tops in aluminium or teak, offering a wide range of material and colour combinations. Available in two heights – standard h75 and h110 for bistro-style settings – Pertre tables stand out for their modularity, durability, and a contemporary yet understated style designed to enhance any space with elegance.

It -

Disegnata dallo studio Zaven, la collezione Pertre nasce per rispondere alle esigenze dell'hospitality contemporanea, con soluzioni versatili che uniscono funzionalità e identità estetica. I tavoli, disponibili in versione tonda o quadrata, si adattano con facilità a diversi contesti e configurazioni. La distintiva gamba triangolare dona carattere alla struttura, mentre le basi in acciaio o cemento si combinano con piani in alluminio o teak, offrendo un'ampia gamma di combinazioni materiche e cromatiche. Disponibili in due altezze – standard h75 e h110 per soluzioni bistrot – i tavoli Pertre si distinguono per la loro modularità, robustezza e uno stile contemporaneo e discreto, pensato per valorizzare ogni spazio con eleganza.

Fr -

Dessiné par le studio Zaven, la collection Pertre est née pour répondre aux besoins de l'hospitalité contemporaine, avec des solutions polyvalentes qui allient fonctionnalité et identité esthétique. Les tables, disponibles en version ronde ou carrée, s'adaptent facilement à différents contextes et configurations. Le pied triangulaire distinctif donne du caractère à la structure, tandis que les bases en acier ou en ciment se combinent avec des plateaux en aluminium ou en teak, offrant une large gamme de combinaisons de matières et de couleurs. Disponibles en deux hauteurs – standard h75 et h110 pour les configurations bistrot – les tables Pertre se distinguent par leur modularité, leur robustesse et un style contemporain et discret, conçu pour mettre en valeur chaque espace avec élégance.





Davos Collection

Design by
Matteo Nunziati

En -

Design by Matteo Nunziati, Davos is a seating system with infinitely modular elements, designed to be used seamlessly both inside and outdoors, thanks to padding and fabrics that replicate the comfort and softness of indoor furnishings. The very lightweight structure is easy to transport and can be assembled in an intuitive way due to the highly sophisticated and innovative production technology. The name is a tribute to the Swiss city at the centre of the Walser population, which has influenced the design of the collection.

It -

Firmato dal designer Matteo Nunziati, Davos è un sistema di sedute a elementi modulari all'infinito, progettato senza soluzione di continuità tra indoor e outdoor, grazie ad una imbottitura e a tessuti che replicano il comfort e la morbidezza degli arredi da interno. La struttura, molto leggera, è facilmente trasportabile e componibile in modo intuitivo grazie ad una tecnologia di produzione altamente sofisticata ed innovativa. Il nome è un omaggio alla città svizzera al centro della popolazione Walser, che ha influenzato il design della collezione.

Fr -

Signé par le designer Matteo Nunziati, Davos est un ensemble d'éléments modulables à l'infini, conçu de manière à assurer une continuité entre intérieur et extérieur, grâce à un rembourrage et à des tissus qui reproduisent le confort et la douceur du mobilier d'intérieur. La structure, très légère, est facilement transportable et modulable de manière intuitive grâce à une technologie de fabrication hautement sophistiquée et innovante. Le nom est un hommage à la ville suisse au centre de la population Walser, qui a influencé le design de la collection.





En -

The aesthetics of the Davos seating system draw inspiration from the rural architecture of the houses of the Walser population. Easy to handle even the soft part of the sofa: the cushions that are placed and fixed on the frame are easily removed in case of adverse weather events or even only at the end of the season.

It -

L'estetica del sistema di sedute Davos trae ispirazione dall'architettura rurale delle case della popolazione Walser. Di facile gestione anche la parte morbida del divano: i cuscini che vengono appoggiati e inseriti sul telaio sono rimovibili facilmente in caso di eventi atmosferici avversi o anche solo a fine stagione.

Fr -

L'esthétique des éléments modulables Davos s'inspire de l'architecture rurale des maisons locales. La partie souple du canapé est également facile à manipuler : les coussins qui sont posés et fixés sur le cadre peuvent être facilement enlevés en cas d'événements météorologiques défavorables ou même à la fin de la saison.



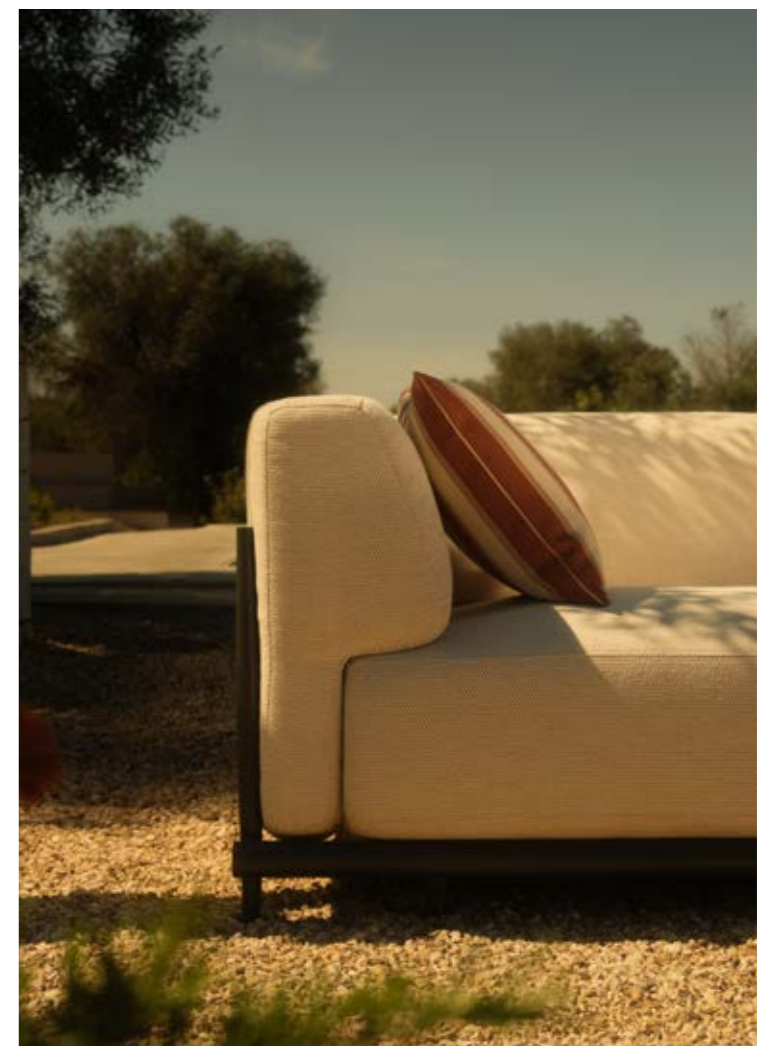

En-
The joints designed for the aluminum structure reflect the wooden ones typical of the historic buildings of this mountain context. The joints present in the structure of the seats are reproduced in the coffee tables.

It-
I giunti studiati per la struttura in alluminio riprendono quelli in legno tipici degli edifici storici di questo contesto montano. I giunti presenti nella struttura delle sedute sono riprodotti nei tavolini in gres porcellanato.

Fr-
Les jointures étudiées pour la structure en aluminium reprennent celles en bois typiques des bâtiments historiques de ce contexte montagnard. Les jointures présentes dans la structure des sièges sont reproduites dans les tables basses en grès cérame.

Treble Collection



En -

Bi-material, the Treble collection is characterised by its lightness, clean lines, high performance when used outdoors and its aesthetic rigour, qualities that make it easily adaptable to urban and residential settings. There are four finishes for the frame and weave: graphite, sage, terracotta and sand. In addition to the modular seating, a rectangular coffee table is also available with a solid teak top.

It -

Bimaterica, in alluminio e corda, la collezione Treble si caratterizza per la leggerezza, la purezza delle linee, l'alta performance nell'utilizzo outdoor e il rigore estetico, qualità che la rendono facilmente adattabile a contesti urbani e residenziali. Quattro le finiture della struttura e dell'intreccio: grafite, salvia, terracotta e sabbia. Oltre alle sedute modulari è disponibile anche un coffee table rettangolare con solido piano in teak.

Fr -

Bi-matière, en aluminium et corde, la collection Treble se caractérise par la légèreté, la pureté des lignes, l'excellente résistance en extérieur et la rigueur esthétique, des qualités qui lui permettent de s'adapter aux contextes urbains et résidentiels. Quatre finitions de la structure et du tressage : graphite, sauge, terracotta et sable. En plus des sièges modulaires, une table basse rectangulaire avec plateau en teck massif complète l'ensemble.



En -

Precious detail, the handcrafted weave of synthetic rope - a material that offers a high performance of weather resistance while recalling to the eye and touch the warmth and softness of natural rope - draws armrests and backrest of the armchair, sofa and modular system.

It -

Prezioso dettaglio, l'intreccio artigianale di corda sintetica - materiale che offre un'elevata performance di resistenza alle intemperie pur richiamando alla vista e al tatto il calore e la morbidezza della corda naturale - disegna braccioli e schienale della poltrona, del divano e del sistema modulare.

Fr -

Détail précieux, le tressage artisanal en corde synthétique - matériau qui offre une grande résistance aux intempéries tout en rappelant à la vue et au toucher la chaleur et la douceur de la corde naturelle - dessine les accoudoirs et le dossier du fauteuil, du canapé et du système modulaire.

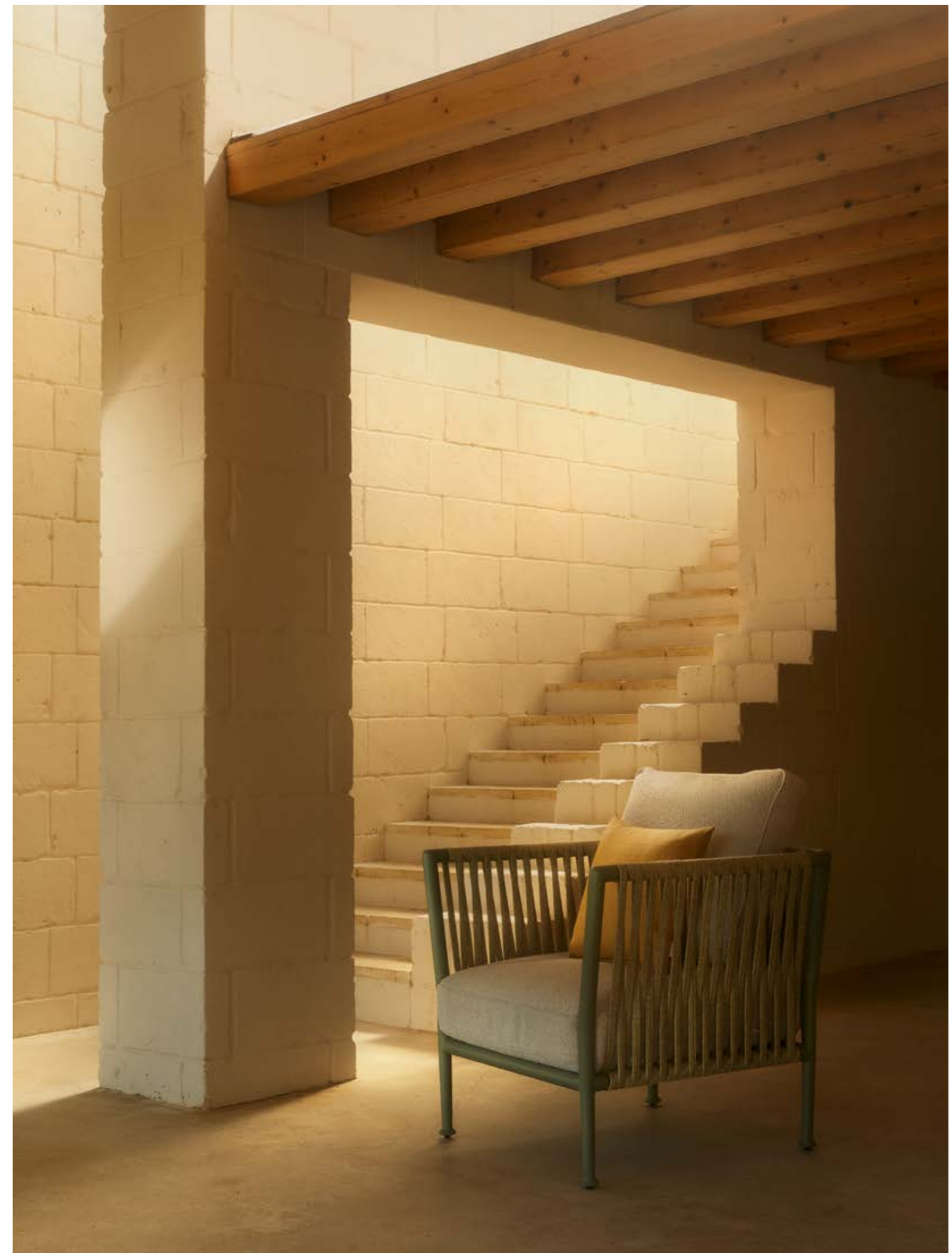



En -

With its elegant and modern style, it is ideal for those seeking versatile solutions that perfectly adapt to both outdoor and indoor spaces, offering an experience of quality and durability.

It -

Con il suo stile elegante e moderno, è ideale per chi cerca soluzioni versatili che si adattano perfettamente sia agli spazi esterni che interni, offrendo un'esperienza di qualità e durabilità.

Fr -

Avec son style élégant et moderne, il est idéal pour ceux qui recherchent des solutions polyvalentes qui s'adaptent parfaitement aux espaces extérieurs et intérieurs, offrant une expérience de qualité et de durabilité.





Lulù Collection

Design by
Daniel Jarefeldt

En

Lulù is a lounge chair, designed by Daniel Jarefeldt, for a wide range of environments, both public and private, outdoor and indoor. Lulù has an elegant and timeless identity but at the same time playful and light, because it resembles a swing. The inspiration initially derives from rattan easy chairs from the 1950s but the form is rationalised into a more contemporary look. The hanging seat in canvas also references classic sun chairs and contributes to a design that gives a light and easy impression. The material palette of coloured metal, warm textile, tactile leather and wooden details contribute to a sophisticated and elegant appearance.

It

Lulù è una poltrona lounge, progettata da Daniel Jarefeldt, per un'ampia gamma di ambienti, sia pubblici che privati, sia indoor che outdoor. Lulù ha un'identità elegante e senza tempo ma al contempo giocosa e leggera, perché ricorda un'altalena. L'ispirazione deriva inizialmente dalle poltrone in rattan degli anni Cinquanta, ma la forma viene razionalizzata in un look più contemporaneo. Anche la seduta sospesa in tela fa riferimento alle classiche sedie a sdraio e conferisce un design che dà un'impressione di leggerezza e semplicità. La palette dei materiali, composta da metallo colorato, tessuto caldo, pelle tattile e dettagli in legno, contribuisce a creare un aspetto sofisticato.

Fr

Lulù est un fauteuil lounge conçu par Daniel Jarefeldt, pour une large gamme d'espaces, à la fois publics et privés, intérieurs et extérieurs. Lulù a une identité élégante et intemporelle, mais aussi ludique et légère, puisqu'elle ressemble à une balançoire. L'inspiration vient initialement des fauteuils en rotin des années 1950, mais la forme est rationalisée dans un look plus contemporain. Le siège suspendu en toile fait également référence aux chaises longues classiques et contribue à distiller un design qui donne une impression de légèreté et de simplicité. La palette des matériaux, composée de métal coloré, de tissu chaud, de cuir tactile et de détails en bois, contribue à créer un aspect sophistiqué.

Toscana Collection



En -

The Toscana collection is a classic icon of handcrafted production in powder-coated galvanized iron. Quality craftsmanship and attention to detail by expert artisans translate into structures with thin and geometric volumes with a contemporary geometric design that characterizes all the elements of the line.

It -

La collezione Toscana è una classica icona di produzione artigianale a mano realizzata in ferro zincato verniciato a polveri. La maestria e l'attenzione al dettaglio di esperti artigiani si traducono in strutture dai volumi geometrici sottili il cui design contemporaneo e geometrico caratterizza tutti gli elementi.

Fr -

La collection Toscana est une icône classique de la production artisanale faite à la main en fer galvanisé et peinture poudre. Le savoir-faire et l'attention au détail d'artisans expérimentés se traduisent par des structures aux volumes géométriques et subtiles, dont le design contemporain et précis caractérise tous les éléments.



En -

A collection that combines tradition and modernity, highlighting the timeless beauty of hand-forged iron.

It -

Una collezione che unisce tradizione e modernità, esaltando la bellezza senza tempo del ferro lavorato a mano.

Fr -

Une collection qui allie tradition et modernité, mettant en valeur la beauté intemporelle du fer travaillé à la main.





En -
The ends of the armrests
of the folding armchair
are curled, giving it a
classic, romantic look.

It -
L'estremità del bracciolo
della poltroncina pieghevole
termina in un motivo
a ricciolo, donandole
un aspetto classico
e romantico.

Fr -
L'extrémité de l'accoudoir
de la chaise pliante
se termine par un motif
de tourbillon, ce qui lui
donne un look classique
et romantique.



Aurora Collection



En

A romantic spirit characterizes this timeless collection: hand-forged and inspired by the Umbrian-Tuscan tradition of the late 1900s, Aurora comes out refined and traditional thanks to its stylishly sinuous shapes. Its powder-coated wrought iron structure is its signature trait, which sums up the perfect combination of elegance and durability.

It

Un'anima romantica caratterizza questa collezione senza tempo: forgiata a mano e ispirata alla tradizione umbro-toscana di inizio '900, Aurora si presenta raffinata e tradizionale grazie alle forme sinuose e chic. La distingue la struttura in ferro battuto verniciata a polveri, che riassume il perfetto connubio tra eleganza e durevolezza.

Fr

Une âme romantique caractérise cette collection intemporelle: forgée à la main et inspirée par la tradition ombro-toscane du début du XXème siècle, Aurora est raffinée et traditionnelle grâce à ses formes sinueuses et chics. Elle se distingue par sa structure en fer forgé peinture poudre, qui résume la combinaison parfaite entre élégance et durabilité.





En -

Timeless beauty and romantic lines, the Aurora collection is rich and complete; it offers all the elements necessary to furnish the outdoors in a timeless style.

It -

Bellezza senza tempo e linee romantiche, la collezione Aurora è ricca e completa; propone tutti gli elementi per arredare l'esterno con uno stile intramontabile.

Fr -

La collection Aurora, riche et complète, se caractérise par sa beauté intemporelle et ses lignes romantiques. Elle propose tous les éléments nécessaires pour aménager vos espaces extérieurs et offre un style intemporel.





Luce Collection



En -

Luce collection is created by the encounter of the aluminium frame with the synthetic rope covering armrests and backrest. The collection gets its name from the effects the light plays off the two materials. The tapered legs, slenderer at the bottom, are a feature of the line that confers a sense of lightness to the furnishings, without forfeiting the stability and solidity ensured by the aluminium.

It -

Luce nasce dall'incontro tra l'alluminio della struttura e la corda sintetica che riveste braccioli e schienale. Il nome della collezione si ispira agli effetti luminosi generati dal gioco tra i due materiali. Le gambe rastremate, che tendono ad assottigliarsi all'estremità, sono la peculiarità della linea: conferiscono leggerezza agli arredi senza rinunciare alla stabilità e solidità garantite dall'alluminio.

Fr -

Luce naît de la rencontre entre l'aluminium de la structure et la corde synthétique qui recouvre les accoudoirs et le dossier. Le nom de la collection s'inspire des effets lumineux générés par le jeu entre les deux matériaux. Les pieds effilés, qui ont tendance à s'amincir à l'extrémité, sont la particularité de la ligne : ils donnent de la légèreté au mobilier sans renoncer à la stabilité et solidité garanties par l'aluminium.



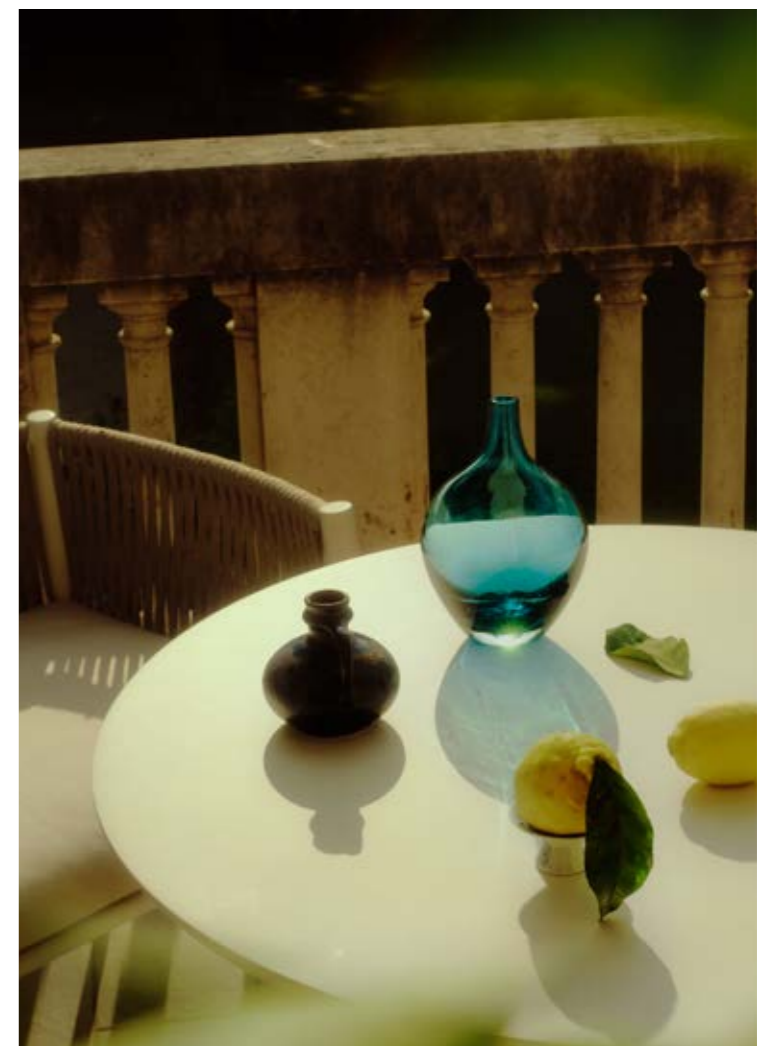

En-
The tables in aluminium
are available in round
or square shapes with
the top in both aluminium
and stoneware finishes

It-
I tavoli in alluminio sono
disponibili nella forma
rotonda o quadrata con
finiture sia nella variante
in alluminio che in gres.

Fr-
Les tables en aluminium
sont disponibles en forme
ronde ou carrée avec
le plateau en aluminium
et en grès.

En -

The collection includes high tables and stools, making it interesting for contract use in pubs, cafes, public dining, and any other entertainment-type venues.

It -

La collezione comprende tavoli alti e sgabelli ideali per l'uso contract in pub, caffè, ristoranti e qualsiasi altro luogo di intrattenimento.

Fr -

La collection comprend des tables hautes et des tabourets. Ceci la rend particulièrement adaptée aux pubs, cafés, restaurants et autres lieux de divertissement.





En -

The Sunbed: ultra-lightweight, versatile, and incredibly comfortable. Its aluminum frame, enhanced by elegant rope detailing, combines aesthetics and functionality. Water- and UV-resistant, it's the ideal choice for outdoor spaces, offering durability and style in every season.

It -

Il lettino: leggerissimo, versatile e incredibilmente comodo. La struttura in alluminio, arricchita da eleganti dettagli in corda, unisce estetica e funzionalità. Resistente all'acqua e ai raggi solari, è la scelta ideale per ambienti outdoor, garantendo durata e stile in ogni stagione.

Fr -

La Chaise Longue: ultra-légère, polyvalente et incroyablement confortable. Sa structure en aluminium, rehaussée de détails élégants en corde, allie esthétique et fonctionnalité. Résistante à l'eau et aux rayons UV, elle est le choix idéal pour les espaces extérieurs, garantissant durabilité et style en toute saison.

En -

The deckchair, a contemporary reinterpretation of the classic sun bed: very lightweight, versatile and comfortable, with a foldable aluminium frame in two colours, graphite and white, and a lightly padded, water and sun resistant cover, in the colours brown and ecru.

It -

La sdraio, una reinterpretazione contemporanea della classica brandina estiva: leggerissima, versatile e comoda, con una struttura pieghevole in alluminio in due tinte, grafite e bianco, e un telo leggermente imbottito e resistente all'acqua e ai raggi solari, nei colori brown ed écru.

Fr -

Un transat intègre la collection Luce, une réinterprétation contemporaine du classique lit de camp d'été : très léger, polyvalent et confortable, avec une structure pliable en aluminium et deux couleurs, graphite et blanc. La toile, légèrement rembourrée et résistante à l'eau et aux rayons du soleil, est dans les couleurs gris/marron et écru.

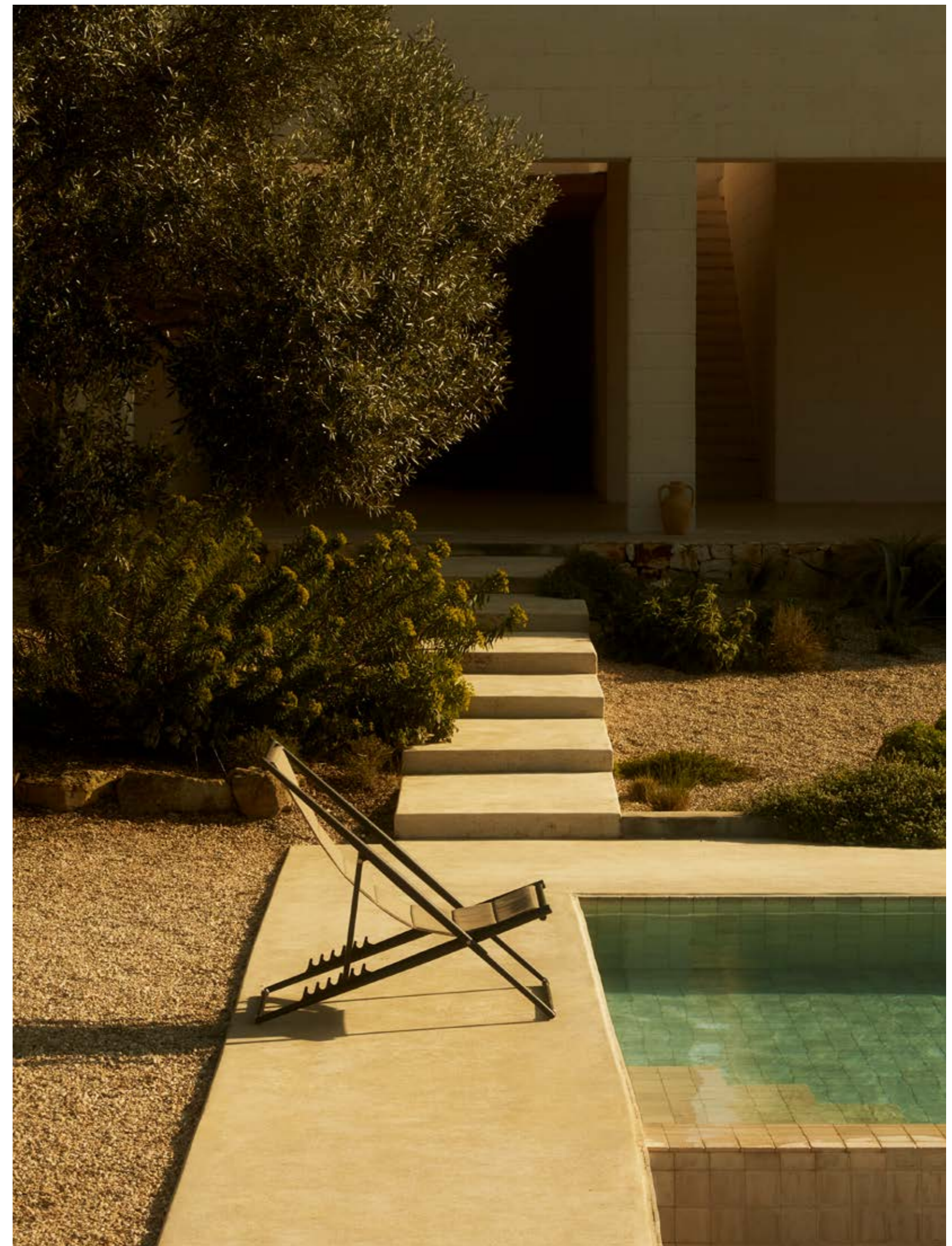

En -

The Luce collection combines modern design, aluminum durability, and rope comfort, offering elegant and functional outdoor solutions. High-quality materials for a refined and lasting style.

It -

La collezione Luce combina design moderno, resistenza dell'alluminio e comfort della corda, offrendo soluzioni eleganti e funzionali per l'outdoor. Materiali di alta qualità per uno stile raffinato e duraturo.

Fr -

La collection Luce allie design moderne, résistance de l'aluminium et confort de la corde, offrant des solutions élégantes et fonctionnelles pour l'extérieur. Des matériaux de haute qualité pour un style raffiné et durable.



Ariete Collection

Design by
Adam D. Tihany



En -

Designed by Adam D. Tihany, Ariete enhances the primary geometry of the circle as a unique feature through which to reinterpret wrought iron work in a contemporary style. The generously sized collection is handcrafted by skilled craftsmen and includes sofas and armchairs that are ideal for decorating environments with timeless elegance.

It -

Disegnata da Adam D. Tihany, Ariete valorizza la geometria primaria del cerchio come tratto peculiare per reinterpretare in chiave contemporanea le lavorazioni in ferro battuto. La collezione dalle proporzioni generose è realizzata a mano da sapienti artigiani, ed include divani e poltrone ideali per arredare gli ambienti con eleganza senza tempo.

Fr -

Conçue par Adam D. Tihany, Ariete valorise la géométrie primaire du cercle et en fait un trait distinctif, tout en modernisant les éléments en fer forgé. Les produits de cette collection aux proportions généreuses sont réalisés à la main par des maîtres artisans et comprennent des canapés, un fauteuil parfaits pour meubler les environnements extérieurs en leur conférant un style élégant et intemporel.



Panarea Collection



En -

This beach lounger is made in aluminum from a technical fabric that combines the resistance of PVC with the softness of weft made from polyester chenille. Available in graphite and white.

It -

Il lettino è realizzato in alluminio con un tessuto tecnico che unisce la resistenza del PVC alla morbidezza della trama composta da ciniglia di poliestere. Disponibile nei colori grafite e bianco.

Fr -

Le bain de soleil est réalisé en aluminium avec un tissu technique qui unit la résistance du PVC à la douceur de la chenille de polyester que composent la trame. Il est disponible dans les couleurs graphite et blanc.



Fresbee Collection



En -

With minimalist and simple lines, the new Fresbee coffee table is the perfect combination of functionality and design. The load-bearing frame is available in two versions, teak or graphite-coloured aluminium. The top, with a diameter of 46 cm, made of graphite-coloured aluminium in both cases, is removable and can therefore be used as a tray. The simple and elegant lines of Fresbee, along with the option to choose the base, enable it to integrate easily with the elements of different Unopiù designer collections.

It -

Minimalista ed essenziale nelle linee, il nuovo coffee table Fresbee rappresenta il perfetto connubio tra funzionalità e design. La struttura portante è disponibile in due versioni, teak oppure alluminio color grafite. Il top, del diametro di 46 cm, realizzato in alluminio color grafite in entrambi i casi, è asportabile e può quindi essere usato come vassoio. Le linee semplici ed eleganti di Fresbee, insieme alla possibilità di scelta della base, gli permettono di integrarsi facilmente con gli elementi di diverse collezioni firmate Unopiù.

Fr -

Minimaliste et épurée dans ses lignes, la nouvelle table basse Fresbee représente la combinaison parfaite entre fonctionnalité et design. La structure portante est disponible en deux versions, teak ou aluminium couleur graphite. Le plateau, d'un diamètre de 46 cm, réalisé en aluminium couleur graphite dans les deux cas, est amovible et peut donc être utilisé comme plateau. Les lignes simples et élégantes de Fresbee, ainsi que la possibilité de choisir la base, lui permettent de s'intégrer facilement aux différentes collections signées Unopiù.

Wooden Collections

02.

Cora
Versilia
Pertre
Synthesis
Ginger
Amanda
Chelsea
Welcome
Pevero
Swing
Clio
Emy
Titanic
William
C'est La Vie
Cosette



Cora Collection

Design by
Federica Biasi

En -

Soft lines, natural materials, and a timeless aesthetic: the Cora family is the perfect blend of comfort and design. Created by Federica Biasi, this outdoor collection combines the strength of teak with the lightness of woven rope, giving life to elegant, inviting, and versatile furniture.

It -

Linee morbide, materiali naturali e un'estetica senza tempo: la collezione Cora è la sintesi perfetta tra comfort e design. Firmata da Federica Biasi, questa famiglia outdoor unisce la solidità del teak alla leggerezza della corda intrecciata, dando vita a un arredo elegante, accogliente e versatile.

Fr -

Lignes douces, matériaux naturels et esthétique intemporelle : la famille Cora est la synthèse parfaite entre confort et design. Signée Federica Biasi, cette collection outdoor associe la solidité du teak à la légèreté de la corde tressée, donnant vie à un mobilier élégant, accueillant et polyvalent.





En -

Designed to make the most of every outdoor moment, Cora features a lounge area with comfortable sofas – perfect for relaxation and socializing – and a dining space enhanced by a round, textured table that brings character to any setting. The collection is completed by single and double sun loungers, as well as a striking sunbed island – ideal for an experience rooted in wellness and style. Cora redefines outdoor living with elegance, functionality, and a truly authentic identity.

It -

Pensata per vivere appieno ogni momento all'aperto, Cora si compone di un'area lounge con divani confortevoli, perfetti per il relax e la convivialità, e una zona dining impreziosita da un tavolo rotondo materico, capace di conferire carattere a qualsiasi ambiente. Completano la collezione i lettini singoli, i lettini doppi e una scenografica isola prendisole, ideali per un'esperienza all'insegna del benessere e dello stile. Cora ridefinisce lo spazio esterno con eleganza, funzionalità e un'identità autentica.

Fr -

Pensée pour profiter pleinement de chaque moment en plein air, Cora se compose d'un espace lounge avec des canapés confortables, parfaits pour la détente et la convivialité, ainsi que d'un espace dining mis en valeur par une table ronde texturée, capable d'apporter du caractère à n'importe quel environnement. La collection est complétée par des bains de soleil simples, doubles, et une spectaculaire île de détente, idéals pour une expérience placée sous le signe du bien-être et du style. Cora redéfinit l'espace extérieur avec élégance, fonctionnalité et une identité authentique.







Versilia Collection

Design by
Keiji Takeuchi

En ▶

The Versilia collection celebrates outdoor conviviality with a design that is both essential and refined. Aluminium frames, available in elegant graphite and chocolate finishes, combine with the natural beauty of teak tops to create a harmonious dialogue between colour and material. The collection includes an extendable rectangular table – perfect for hosting many guests on special occasions – and a round table.

It ▶

La collezione Versilia celebra la convivialità all'aperto con un design essenziale e raffinato. Le strutture in alluminio, declinate nelle eleganti finiture grafite e cioccolato, si combinano con la naturalezza dei piani in teak, creando un dialogo armonico tra colore e materia. La famiglia si compone di un tavolo rettangolare allungabile, perfetto per accogliere numerosi ospiti in occasioni speciali, e di un tavolo rotondo.

Fr ▶

La collection Versilia célèbre la convivialité en plein air avec un design à la fois essentiel et raffiné. Les structures en aluminium, proposées dans les élégantes finitions graphite et chocolat, se marient à la naturalité des plateaux en teak, créant un dialogue harmonieux entre couleur et matière. La gamme se compose d'une table rectangulaire extensible, idéale pour accueillir de nombreux convives lors d'occasions spéciales, et d'une table ronde.



En -
Design, functionality and
comfort come together
in tables created to
experience conviviality
with elegance, every day.

It -
Design, funzionalità e
comfort si fondono in
tavoli pensati per vivere
la convivialità con
eleganza, ogni giorno.

Fr -
Design, fonctionnalité et
confort se fondent dans des
tables conçues pour vivre la
convivialité avec élégance,
chaque jour.

Synthesis Collection



En -

Synthesis is a contemporary collection with an essential design, where the stylish combination of teak and hand-woven WaProLace® synthetic fibre plays a role in enhancing the purity of its lines. Craftsmanship and attention to detail are the identifying features of the many products in the collection.

It -

Synthesis è una collezione contemporanea dal design essenziale: l'elegante connubio tra teak e fibra sintetica WaProLace® intrecciata a mano contribuisce a esaltarne la purezza di linee. Lavorazione artigianale e cura del dettaglio sono tratti identificativi dei molteplici prodotti della collezione.

Fr -

Synthesis est une collection contemporaine au design essentiel : l'élégante combinaison de teck et de fibre synthétique WaProLace® à la main contribue à exalter la pureté des lignes. Le travail artisanal et l'attention donnée aux détails sont des traits distinctifs des nombreux éléments de la collection. une durabilité maximale.





En -
The loungers are
adjustable from both
sides and designed to
meet multiple living needs.

It -
I lettini sono regolabili
da entrambi i lati, pensati
per rispondere alle
molteplici esigenze abitative.

Fr -
Les transats, réglables
de chaque côté, sont
conçus pour s'adapter
aux divers besoins des
espaces d'habitation.



En -

Synthesis is characterised by its versatility and ability to adapt to multiple living solutions. Thanks to the use of fine materials and careful workmanship, the collection transforms each room into an elegant, sophisticated and contemporary landscape.

It -

Synthesis si caratterizza per la sua versatilità e capacità di adattarsi a molteplici soluzioni abitative. Attraverso l'uso di materiali pregiati e l'accurata lavorazione la collezione trasforma ciascun ambiente in un paesaggio elegante, sofisticato e contemporaneo.

Fr -

Synthesis se distingue par sa polyvalence et sa capacité à s'adapter à de multiples solutions d'aménagement. Composée de matériaux précieux et se caractérisant par le soin apporté aux détails, cette collection transforme tout type d'environnement en un cadre élégant, raffiné et contemporain.



En -

The alcove is a truly welcoming and enveloping environment. Both ends are designed to allow its use to be fully customised. The height is adjustable and can be converted into a comfortable backrest. The curtains design the exterior, filtering the sun and creating continuity between the interior space, the surrounding environment and those inhabiting it.

It -

L'alcova costituisce un vero e proprio ambiente accogliente, e avvolgente. Entrambe le estremità sono pensate per lasciare piena personalizzazione nel suo utilizzo. L'altezza è regolabile e trasformabile in un comodo schienale. Le tende disegnano l'esterno, filtrando il sole e creando un continuo dialogo tra lo spazio interno, l'ambiente circostante e chi lo abita.

Fr -

L'alcôve offre un cadre accueillant et chaleureux. Les deux extrémités sont conçues de manière à permettre une totale personnalisation de son utilisation. La hauteur est réglable et permet d'obtenir un dossier confortable. Le voilage protège de l'extérieur, filtrant le soleil et créant un dialogue continu entre l'espace interne, l'environnement et les occupants.

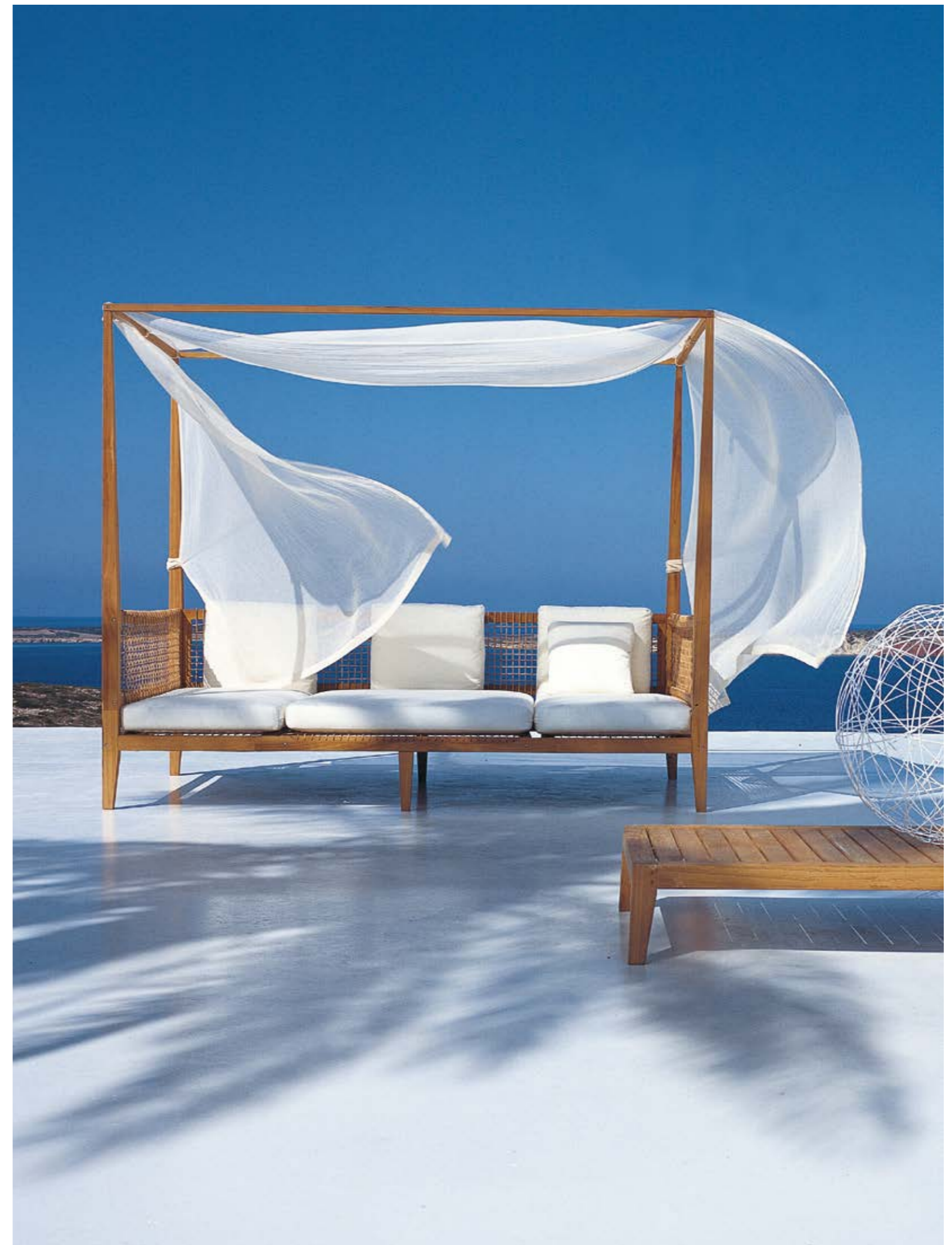



Ginger Collection



En -

Feel like a movie star with the timeless Unopiù director's chair. Ginger is a folding, light and comfortable chair that can be the main character of any decor.

It -

Sentirsi come una star del cinema con l'intramontabile poltroncina da regista di Unopiù. Ginger è una sedia pieghevole, leggera e confortevole che sarà protagonista di qualsiasi tipo di arredo.

Fr -

Se sentir comme une star de cinéma avec l'intemporel fauteuil de réalisateur d'Unopiù. Ginger est une chaise pliante légère et confortable qui sera la star de n'importe quel décor.



En -

It can be customized with all the colors available in the Color Collection, offering a wide range of matching possibilities, even for indoor spaces. Its timeless design blends naturally and elegantly into a variety of settings, combining functionality and style.

It -

Può essere personalizzata con tutti i colori disponibili nella Color Collection, offrendo ampie possibilità di abbinamento anche per gli spazi interni. Il suo design senza tempo si integra con naturale eleganza in diversi contesti, unendo funzionalità e stile.

Fr -

Elle peut être personnalisée avec toutes les couleurs disponibles dans la Color Collection, offrant de nombreuses possibilités d'association, y compris pour les espaces intérieurs. Son design intemporel s'intègre avec une élégance naturelle dans différents contextes, alliant fonctionnalité et style.



En -

Durable, versatile, and timeless in design, Ginger brings a touch of elegance and functionality to any space.

It -

Resistente, versatile e dal design intramontabile, Ginger porta un tocco di classe e funzionalità in ogni spazio.

Fr -

Robuste, polyvalente et au design intemporel, Ginger apporte une touche de classe et de fonctionnalité à chaque espace.



Amanda Collection



En -

Among the most iconic products of the Unopiù brand, the Amanda hammock harmoniously brings together comfort, design, and excellence of craft. The self-supporting structure in curved laminated wood in shades of walnut effortlessly manages to transform any environment into an elegant personal space, a place to indulge in relaxation.

It -

Tra i prodotti più iconici del brand Unopiù, l'amaca Amanda coniuga armoniosamente comfort, design ed eccellenza artigianale. La struttura autoportante in legno lamellare curvato, nei toni del noce, riesce a trasformare qualsiasi ambiente in un elegante spazio personale, un luogo dove abbandonarsi al relax.

Fr -

Parmi les produits les plus emblématiques de la marque Unopiù, le hamac Amanda allie harmonieusement confort, design et excellence artisanale. La structure autoportante en bois lamellé courbé, dans les tons Noyer, réussit à transformer n'importe quel environnement en un élégant espace personnel, un lieu où s'abandonner à la détente.

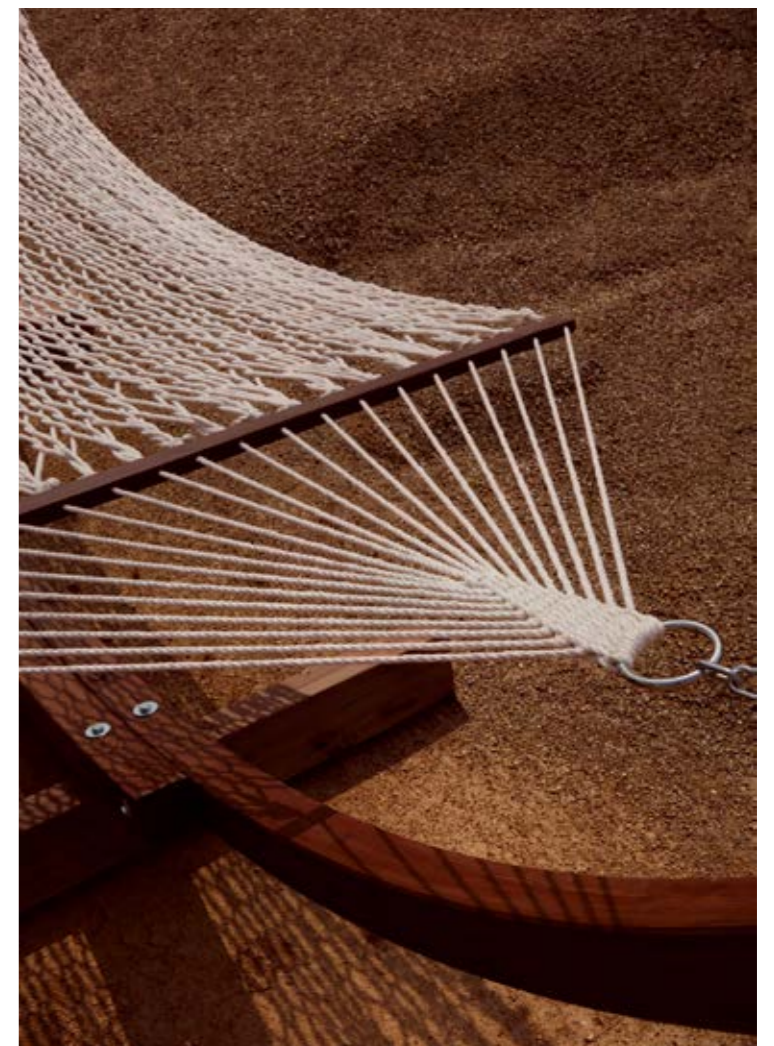

En -

The woven rope net can be either white or in shades of grey and can accommodate up to two people. Comfortable and ideal for a moment's relaxation, it establishes a harmonious dialogue with nature.

It -

La rete dalla corda intrecciata può essere di colore bianco o grigio mélange e permette di ospitare fino a due persone. Confortevole e ideale per un momento di relax, instaurando un armonioso dialogo con la natura.

Fr -

Le filet en corde tressée est proposé en blanc ou gris chiné et permet d'accueillir jusqu'à deux personnes. Confortable et idéal pour profiter d'un moment de détente, il instaure un harmonieux dialogue avec la nature.

Chelsea Collection



En

The Chelsea line is classic and traditional, entirely made of honey-coloured teak, a shade that enhances the naturalness and warmth of the material. This highly articulated collection includes sofas, tables, chairs, loungers and deck chairs, allowing the outdoor space to be transformed into a welcoming, familiar landscape.

It

Chelsea è una linea dal gusto classico e tradizionale, interamente realizzata in teak color miele, tonalità che valorizza la naturalezza ed il calore del materiale. La collezione molto articolata include divani, tavoli, sedute, lettini e sdraio, per permettere di trasformare lo spazio esterno in un paesaggio accogliente e familiare.

Fr

Chelsea est une ligne au style classique et traditionnel entièrement réalisée en teck de couleur miel, une tonalité qui met en valeur l'aspect naturel et chaleureux de ce matériau. Cette collection très structurée inclut des canapés, des tables, des sièges, des transats et des chaises longues et permet de transformer son espace extérieur en un cadre accueillant et intime.





En -

The sofas and armchairs stand out due to their solid shapes and harmonious forms, which enhance the technical and aesthetic characteristics of the teak. The coffee table is characterised by a pattern of elegant horizontal slats, which lighten the compact, basic structure.

It -

I divani e le poltrone si distinguono per le forme dolci e armoniose che esaltano le caratteristiche tecniche ed estetiche del teak. Il tavolino è caratterizzato da una trama di eleganti doghe orizzontali, che alleggeriscono la struttura compatta ed essenziale.

Fr -

Les canapés et les fauteuils présentent des volumes solides et des formes harmonieuses qui exaltent les caractéristiques techniques et esthétiques du teck. La table basse se caractérise par l'élégante trame formée par les lattes horizontales qui allègent la structure compacte et épurée.



En -

The table with horizontal slats is extendable, to allow different sized spaces to be furnished.

It -

Il tavolo dalle doghe orizzontali è allungabile, per permettere di arredare spazi di diverse dimensioni.

Fr -

La table aux lattes horizontales est extensible et permet d'aménager des espaces de différentes dimensions.



En -

The trunk that completes the line: from above and from the front. Made of solid teak with stainless steel hardware, it is essential for storing cushions and objects.

It -

Il baule che completa la linea è realizzato in teak massello con ferramenta in acciaio inox. Fondamentale per riporre cuscini ed oggetti.

Fr -

Le coffre qui complète cette ligne, réalisé en teck massif et doté d'une quincaillerie en acier inoxydable. Il est très pratique pour ranger les coussins et des objets.

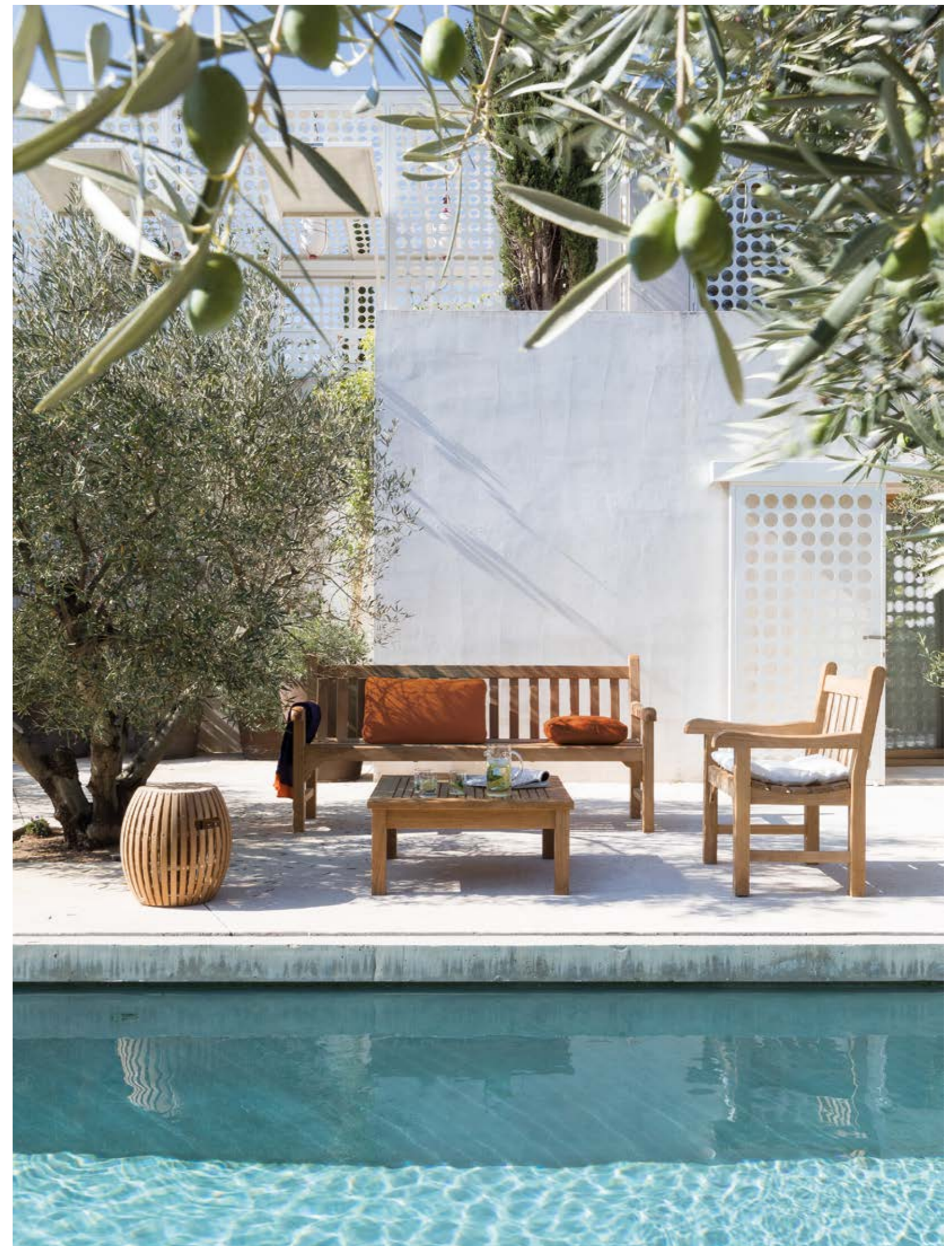

Welcome Collection



En -

Elegant and timeless in style, the Welcome line is offered in a refined teak version. Its modular design allows for the flexible arrangement of areas dedicated to relaxation and socializing, adapting to personal needs and blending harmoniously into any outdoor space.

It -

Elegante e dallo stile senza tempo, la linea Welcome è proposta nella raffinata versione in teak. La modularità degli arredi consente di configurare liberamente zone dedicate al relax e alla convivialità, adattandosi alle esigenze personali e integrandosi con naturale armonia negli spazi outdoor.

Fr -

Élégante et au style intemporel, la ligne Welcome est proposée dans une version raffinée en teck. La modularité des éléments permet d'aménager librement des espaces de détente et de convivialité, en s'adaptant aux besoins de chacun et en s'intégrant harmonieusement dans tout environnement extérieur.



En -

The line mainly consists of generously proportioned teak sofas mounted on aluminium legs, a detail that adds finesse and personality.

It -

La linea si compone principalmente da divani in teak dalle proporzioni generose montati su piedi in alluminio, dettaglio che aggiunge preziosità e personalità.

Fr -

Cette ligne se compose principalement de canapés en teck aux dimensions généreuses montés sur pieds en aluminium, un détail qui ajoute une touche de raffinement et de caractère.





Pevero Collection



En

Pevero is an outstanding example of Unopiù's expertise in teak craftsmanship – a fine material known for its excellent technical qualities. The collection is defined by the geometric design of the frames and by interlocking joints inspired by Eastern tradition, enhanced by the wood's natural finish, which follows the lines and highlights every formal detail.

It

Pevero è un eccellente esempio dell'expertise di Unopiù nella lavorazione del teak, materiale pregiato dalle ottime caratteristiche tecniche. La collezione è contraddistinta dalla geometria dei telai e dalle lavorazioni a incastro ispirate al mondo orientale e valorizzate dalla finitura naturale del legno, che segue le linee e ne esalta i dettagli formali.

Fr

Pevero est un excellent exemple du savoir-faire d'Unopiù dans le travail du teck, un matériau noble aux excellentes qualités techniques. La collection se distingue par la géométrie de ses structures et par les assemblages à tenon et mortaise inspirés de la tradition orientale, sublimés par la finition naturelle du bois qui en suit les lignes et en accentue les détails formels.



En -

Offered in two versions, the collection includes a chair fully made of teak with wide slats and a version with a rope seat and backrest, combining comfort and visual lightness.

It -

Proposta in due versioni, la collezione comprende una sedia interamente in teak con larghe doghe e una variante con seduta e schienale in corda, per unire comfort e leggerezza estetica.

Fr -

Proposée en deux versions, la collection comprend une chaise entièrement en teak avec de larges lattes et une variante avec assise et dossier en corde, alliant confort et légèreté esthétique.



Swing Collection



En -

Soft, elegant lines and an ergonomic shape make Swing collection ideal for moments of relaxation. The skillful crafting of thermo-curved teak wood slats gives sinuous and welcoming look to the elements of the Swing line.

It -

Linee elegantemente morbide e forma ergonomica rendono la collezione Swing ideale per momenti di relax. La sapiente lavorazione dei listelli in legno di teak termo-curvato dona un aspetto sinuoso e accogliente agli elementi della linea Swing.

Fr -

Des lignes élégamment douces et une forme ergonomique rendent la collection Swing idéale pour des moments de détente. Le travail habile des lattes en bois de teck thermo-courbé donne un aspect sinueux et accueillant aux éléments de la ligne Swing.





En -
The chaise-longue, with its soft lines and ergonomic shape, is ideal for moments of relaxation.

It -
La chaise-longue dalle linee dolci e dalla forma ergonomica è ideale per momenti di relax.

Fr -
La chaise-longue, qui offre des lignes douces et une forme ergonomique, est idéale pour les moments de relaxation.





Clio Collection

En -

The subtle, classic elegance of Clio, the folding teak deckchair, brings to mind sophisticated atmospheres, chic and slightly retro – the decking of very exclusive swimming pool and spas, the deck of a cruise ship, Mediterranean promenades, any outdoor relaxation area.

It -

La sottile, classica raffinatezza di Clio, sdraio pieghevole in teak, porta alla mente atmosfere sofisticate, chic e un po' retrò – il bordo di piscine e terme molto esclusive, il ponte di una nave da crociera, in lungomare del Mediterraneo, qualsiasi area di relax all'aperto.

Fr -

Le raffinement subtil et classique de Clio, transat pliant en teck, évoque des ambiances sophistiquées, chics et légèrement rétro - le bord des piscines et des spas très exclusifs, le pont d'un bateau de croisière, un front de mer méditerranéen, tout espace de détente en plein air.



En
The 100% cotton fabric is fitted with a handy pocket for a pillow.

It
Il telo in cotone è dotato di una pratica apertura dove è possibile inserire un cuscino.

Fr
La toile en coton est dotée d'une ouverture pratique où il est possible d'y insérer un coussin.

Emy Collection



En -

Timeless elegance and comfort describe the Emy folding armchair, inspired by the classic Tripoline, brought to fame in the 19th century by English officers who made use of it on safaris and military campaigns. The seat with large pockets rests on a honey-colored teak structure, equipped with an ingenious mechanism that allows it to be closed.

It -

Eleganza e praticità senza tempo per la poltroncina pieghevole Emy, ispirata alla classica Tripolina, resa celebre dagli ufficiali Inglesi che la utilizzavano nei safari e nelle campagne militari del XIX secolo. La seduta con grosse tasche appoggia su gambe in teak, dotate di un ingegnoso meccanismo che ne permette la chiusura.

Fr -

Élégance intemporelle et praticité pour le fauteuil pliant Emy, inspiré du fauteuil classique Tripolina, rendu célèbre par les officiers britanniques qui l'utilisaient lors des safaris et des campagnes militaires au XIXe siècle. Le siège, doté de grandes poches, repose sur des pieds en teck, dotés d'un ingénieux mécanisme qui permet de le fermer, ce qui le rend particulièrement adapté aux environnements extérieurs.



Titanic Collection

En -

Inspired by century-old deckchairs typical of the first luxury ocean liners, the Titanic chaise longue in teak and brass is foldable, adjustable in three positions and equipped with a removable footrest.

It -

Ispirata al design d'antan delle sdraio da ponte apparse sui primi transatlantici da crociera, la chaise longue Titanic, in teak e ottone, è pieghevole, regolabile in tre posizioni ed è dotata di un poggiatesta amovibile.

Fr -

Inspirée du design désuet des chaises longues apparues sur les premiers paquebots de croisière, la chaise longue Titanic, en teck et laiton, est pliable, réglable en trois positions et dotée d'un repose-pied amovible.



En -

The Chaise longue has a removable footrest. The reclining backrest, enriched by a soft cushion, offers a special kind of comfort. Its traditional lines lend it an air of timelessness.

It -

La Chaise longue è composta dal poggiatesta amovibile. Lo schienale reclinabile arricchito dal soffice cuscino offre un comfort speciale. Le sue linee tradizionali la rendono un pezzo dal sapore senza tempo.

Fr -

La chaise longue est composée d'un repose-pied amovible. Le dossier inclinable orné d'un coussin moelleux offre un confort inimitable. Ses lignes classiques en font un meuble au style intemporel.



William Collection



En -

Using tradition as a reference point, the William chair enhances the sinuous variations typical of teak wood, creating refined and timeless atmospheres. Folding chair made from the original "Viken" design of Madame G. Norin.

It -

Facendo della tradizione il suo riferimento, la sedia William valorizza le sinuose declinazioni proprie del legno di teak, creando atmosfere raffinate e senza tempo. Realizzata su disegno originale "Viken" di Madame G. Norin.

Fr -

Faisant de la tradition sa référence, la chaise William met en valeur les déclinaisons sinueuses propres au bois de teck, en créant des atmosphères raffinées et intemporelles. Le modèle original "Viken" a été dessiné par Madame G. Norin.



C'est La Vie Collection

Design by
Michele Bönan

En

Designed by Michele Bönan, the C'est La Vie collection stands out due to its construction in precious polished sapelli mahogany, a material that lends elegance, solidity and harmony to each element. Polishing enhances its lines, making the material pleasant to the touch and generating an alluring complicity between the piece of furniture and the reflections of the natural environment.

It

Disegnata da Michele Bönan, C'est La Vie è una collezione che si distingue per la sua realizzazione in pregiato legno di mogano Sapelli lucidato, materiale che conferisce eleganza, solidità ed armoniosità a ciascun elemento che la compone. La lucidatura esalta le sue linee, rendendo il materiale piacevole al tatto e generando un affascinante dialogo tra il mobile e i riflessi dell'ambiente naturale.

Fr

Conçue par Michele Bönan, C'est La Vie est une collection qui se distingue par l'utilisation de bois précieux d'acajou Sapelli poli, un matériau qui confère un style élégant et harmonieux ainsi qu'une grande robustesse à tous les éléments qui la composent. Les lignes sont mises en valeur par la brillance du bois, un matériau agréable au toucher qui permet de créer un dialogue fascinant entre le mobilier et les reflets de l'environnement naturel.

En -

The natural veins draw delicate motifs that complement the geometric lines of the collection, giving the furnishings a timeless class.

It -

Le venature naturali disegnano motivi delicati che completano le linee geometriche della collezione, donando agli arredi una classe senza tempo.

Fr -

Les veinures naturelles dessinent des motifs délicats qui viennent enrichir les lignes géométriques de cette collection et qui lui confère un style luxueux intemporel.





En -

The collection stands out due to its careful attention to every little detail: from the removable table tops and loungers with adjustable backrests, to the polished stainless-steel legs that decorate and enrich each element.

It -

La collezione si distingue per la cura attenta a ciascun minimo dettaglio: dai piani estraibili del tavolo e lettini con lo schienale regolabile, sino ai piedini in acciaio inossidabile lucido che decorano e arricchiscono ogni elemento.

Fr -

Cette collection se caractérise par le soin minutieux apporté au moindre détail, des plateaux de table coulissants aux transats au dossier réglable et aux pieds en acier inoxydable brillant, qui décorent et mettent en valeur chaque élément.



Cosette Collection



En -

The collection consists of an extendable rectangular table, a deck chair and folding armchairs, available in both aluminium and teak with a cover in dove grey synthetic fabric or in white hemp and soft grey technical fabric. Both choices guarantee maximum durability and weather resistance.

It -

La collezione si compone di un tavolo rettangolare allungabile, uno sdraio e poltroncine pieghevoli, disponibili sia in alluminio che in teak con rivestimento in tessuto sintetico color tortora o in tessuto tecnico bianco canapa e grigio tenue. Entrambe le scelte garantiscono massima durabilità e resistenza agli agenti atmosferici.

Fr -

La collection se compose d'une table rectangulaire extensible, un transat et des fauteuils pliants, disponibles en aluminium ou en teck avec revêtement en tissu synthétique couleur tourterelle ou en tissu technique blanc chanvre et gris tendre. Les deux choix garantissent une durabilité et une résistance maximales aux agents atmosphériques.



En -

Lightweight and versatile, the small armchairs combine the warmth of teak and the practicality of technical fabric with solid and precious materials.

It -

Leggere e versatili, le sedie abbinano il calore del teak e la praticità del tessuto tecnico con materiali solidi e pregiati.

Fr -

Légers et polyvalents, les petits fauteuils allient la chaleur du teck et la praticité du tissu technique avec des matériaux solides et précieux.



Fibre
Collections

03.

Agorá
Experience
Nacre
Olimpia
Capri

Agorà Collection



En -

Agorà stands out due to its soft, organic forms. The rounded, enveloping character found in each product in the collection expresses a sense of comfort. The aluminium frame is as light as it is sturdy and its combination with the fibre, which is resistant to any atmospheric agent, gives it a sense of timelessness.

It -

Agorà si distingue per le sue forme morbide ed organiche. Il carattere tondeggiante e avvolgente ricorre in ciascun prodotto della collezione esprimendo un senso di comfort. La struttura in alluminio è tanto leggera quanto robusta e la combinazione con la fibra, resistente a tutti gli agenti atmosferici, le conferisce un sapore senza tempo.

Fr -

Agorà se distingue par ses formes souples et naturelles. La rondeur et la douceur se retrouvent dans tous les éléments de la collection et lui confèrent un style douillet et confortable. La structure en aluminium, aussi légère que robuste, se combine à la fibre, qui résiste à tous les agents atmosphériques, et confère un style intemporel.





En ~

Agorà consists of versatile, modular furnishings that allow the creation of linear and L-shaped configurations and linear sofas, customising outdoor spaces according to any need.

It ~

Agorà si compone di arredi versatili e modulari che permettono di creare configurazioni lineari ed a L, personalizzando gli spazi esterni in base a ogni esigenza.

Fr ~

Agorà se compose de meubles polyvalents et modulaires qui permettent de créer des configurations linéaires et de personnaliser les espaces extérieurs en fonction des diverses exigences.

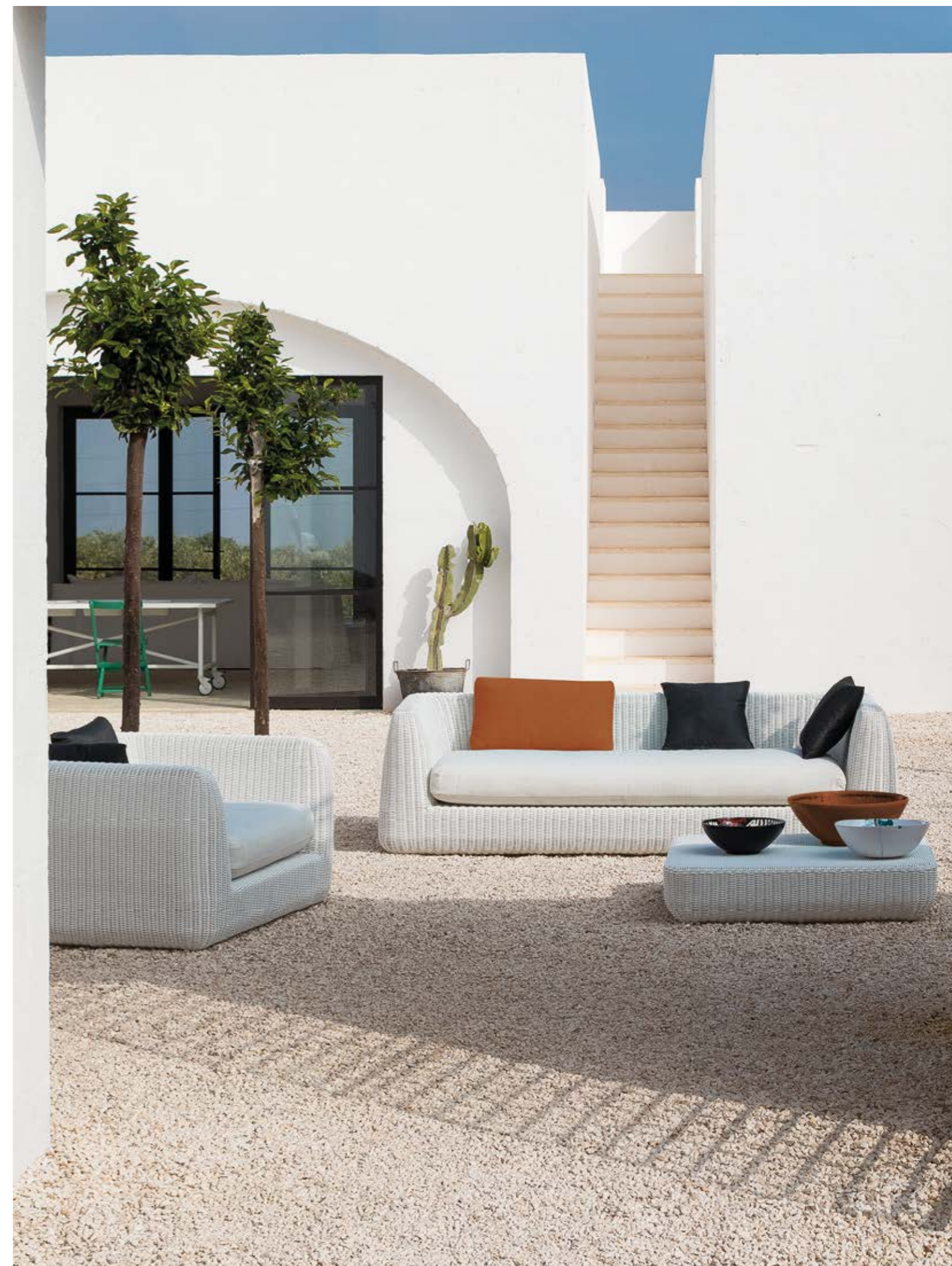

Experience Collection



En

This monochromatic collection is characterized by the coming together of graphite-colored aluminum and expertly hand woven WaProLace® fibre.

It

La collezione monocromatica è caratterizzata dall'accostamento di alluminio color grafite e fibra sintetica WaProLace®, sapientemente tessuta a mano.

Fr

La collection monochrome se caractérise par la combinaison de l'aluminium graphite et de la fibre synthétique WaProLace®, savamment tissée à la main.



En -
The light, slender structure
mixed with the craftsmanship
of the weave make
Experience an elegant,
sophisticated line.

It -
La struttura leggera
e slanciata mescolata
all'artigianalità dell'intreccio,
rendono Experience una
linea elegante e raffinata.

Fr -
La structure légère et
élancée et le tressage
de style artisanal apportent
une touche élégante et
raffinée à la ligne Experience.



En -

Clean lines and the contrast of materials provide visual lightness and sophistication. Perfect for those seeking comfort without sacrificing contemporary design and long-lasting durability.

It -

Le linee pulite e il contrasto tra materiali donano leggerezza visiva e raffinatezza. Perfetta per chi cerca comfort senza rinunciare a design contemporaneo e durabilità nel tempo.

Fr -

Les lignes épurées et le contraste des matériaux apportent légèreté visuelle et raffinement. Parfaite pour ceux qui recherchent le confort sans renoncer au design contemporain et à la durabilité dans le temps.

Nacre Collection



En

Perfect for chilling out, relaxing and socialising. Inspired by the French term "nacre", meaning mother of pearl, this armchair features soft lines of the profile and rounded shapes reminiscent of a shell. The conical truncated legs, made of graphite-coloured aluminium, give it stability and lightness. The seat is wrapped in a recyclable WaProLace® synthetic fibre rope, in a warm antique brown colour, which gives it a refined feel.

It

Chillout, rilassante e conviviale. Ispirata al significato del termine francese "nacre", ossia madreperla, Nacre è una poltroncina che si caratterizza per le linee morbide del profilo e le forme tondeggianti che richiamano una conchiglia. Le gambe a tronco conico, realizzate in alluminio color grafite, conferiscono stabilità e leggerezza al prodotto. La seduta è avvolta da una corda in fibra sintetica WaProLace® riciclabile, dal caldo colore antique brown, che le dona un tocco ricercato.

Fr

Chillout, délassante et conviviale. Prenant pour source d'inspiration le sens du terme français «nacre», cette chaise de jardin arbore lignes douces et formes arrondies qui évoquent un coquillage. Les pieds coniques, réalisés en aluminium de couleur graphite, sont un emblème de stabilité et de légèreté. L'assise est enveloppée par une corde de fibres synthétiques recyclables WaProLace® de couleur antique brown, qui lui apporte une touche raffinée.

Olimpia Collection



En -

The collection revisits Mediterranean traditional aesthetic criteria. Supple, sinuous shapes characterize all the elements in this collection, its distinctive feature being the hand-woven weave of WaProLace® synthetic fibre. This elegant pattern covers up the aluminum frame, enhancing its voluptuous, enveloping contours.

It -

La collezione nasce come rivisitazione delle linee tradizionali mediterranee. Le forme dolci e sinuose ricorrono in tutti gli elementi della serie, il cui tratto caratteristico è l'intreccio a mano in fibra sintetica WaProLace®. La trama elegante ricopre interamente la struttura in alluminio, valorizzandone i volumi lussuosi e avvolgenti.

Fr -

La collection est née comme une réinterprétation des lignes traditionnelles méditerranéennes. Les formes douces et sinueuses se retrouvent dans tous les éléments de la série, dont le trait caractéristique est le tressage à la main en fibre synthétique WaProLace®. La trame élégante recouvre entièrement la structure en aluminium, mettant ainsi en valeur les volumes voluptueux et enveloppants.



Capri Collection



En -

Colourful and comfortable, Capri is a collection of armchairs made from WaProLace® synthetic fibre, skilfully hand-woven by decorator craftsmen, with aluminium tubing. It is practical, light and versatile, while the stonewashed fibre recreates an evocative atmosphere with a retro feel.

It -

Colorata e confortevole, Capri è una collezione di poltroncine in fibra sintetica WaProLace®, sapientemente intrecciata a mano da artigiani decoratori, con tubolare in alluminio. È pratica, leggera e versatile, la fibra delavée ricrea una suggestiva atmosfera dal gusto rétro.

Fr -

Colorée et confortable, Capri est une collection de fauteuils en fibre synthétique WaProLace® soigneusement tressée à la main par des artisans décorateurs à l'aide de tubes en aluminium. Pratique, légère et polyvalente, la fibre délavée crée une ambiance pittoresque au style rétro.



Sunshades

04.

Meridienne

Shibuya

Tibisco

Solaire

Lipari

Salento

Damian

Orangerie

Manta

Nagi

Levante

Riviera

Covercar

Dafne



Meridienne Collection

En -

Clean lines, a solid structure, and maximum versatility: the Meridienne pergola, made entirely of aluminium, is the ideal solution to enhance and complete any outdoor space. Available in both wall-mounted and freestanding versions, it stands out for its modular design and exceptional functionality, making it perfectly suited to the diverse needs of both residential and contract settings.

It -

Linee pulite, struttura solida e massima versatilità: la pergola Meridienne, realizzata interamente in alluminio, è la soluzione ideale per completare e valorizzare ogni spazio outdoor. Disponibile sia in versione adossata che autoportante, si distingue per il suo design modulare e l'estrema funzionalità, che la rendono perfetta per rispondere alle diverse esigenze del mondo residenziale e contract.

Fr -

Lignes épurées, structure solide et polyvalence maximale : la pergola Meridienne, entièrement réalisée en aluminium, est la solution idéale pour compléter et valoriser tout espace extérieur. Disponible en version adossée ou autoportante, elle se distingue par son design modulaire et sa grande fonctionnalité, la rendant parfaite pour répondre aux différentes exigences des univers résidentiels et contract.



En -
Meridienne defines
space with elegance
and precision, offering
a comfortable open-air
refuge in perfect harmony
with its surroundings.

It -
Meridienne definisce
lo spazio con eleganza
e rigore, offrendo un
rifugio confortevole all'aria
aperta, in perfetta armonia
con l'ambiente circostante.

Fr -
Meridienne définit
l'espace avec élégance
et rigueur, offrant un abri
confortable en plein air,
en parfaite harmonie
avec l'environnement.



Shibuya® Collection

Design by
Ferruccio Laviani



En

Designed by Ferruccio Laviani, Shibuya is the first mobile pergola introducing the concept of dynamism, thus revolutionizing the static architectural canons of traditional structures. The aluminum structure is available as a unit that can be secured to the ground. Otherwise, Shibuya can be fitted with four locking wheels for maximum freedom of movement.

It

Disegnata da Ferruccio Laviani, la pergola mobile Shibuya è stata la prima a introdurre il concetto di dinamismo, rivoluzionando il principio architettonico di staticità delle strutture tradizionali. La struttura in alluminio è disponibile come unità fissa da ancorare al suolo; in alternativa, la si può fissare su quattro ruote con blocco, per dare la massima libertà di movimento.

Fr

Dessinée par Ferruccio Laviani, la pergola mobile Shibuya a été la première à introduire le concept de dynamisme, révolutionnant le principe architectural des structures traditionnelles statiques. La structure en aluminium est disponible comme unité fixe à ancrer au sol; alternativement, elle peut être fixée sur quatre roues avec blocage, pour donner une liberté maximale de mouvement.





En ~

Free-standing or wall-mounted, the pergola is completed by different types of roofs, which guarantee excellent shelter from the sun, designing light, elegant shadows in the environment.

It ~

Autoportante o addossata, la pergola si completa con diverse tipologie di coperture, che garantiscono un ottimo riparo dal sole, disegnando ombre leggere ed eleganti nell'ambiente.

Fr ~

Autoportante ou adossée, la pergola peut être complétée de divers types de couvertures offrant une protection optimale contre le soleil et créant des ombres légères et élégantes dans l'environnement.

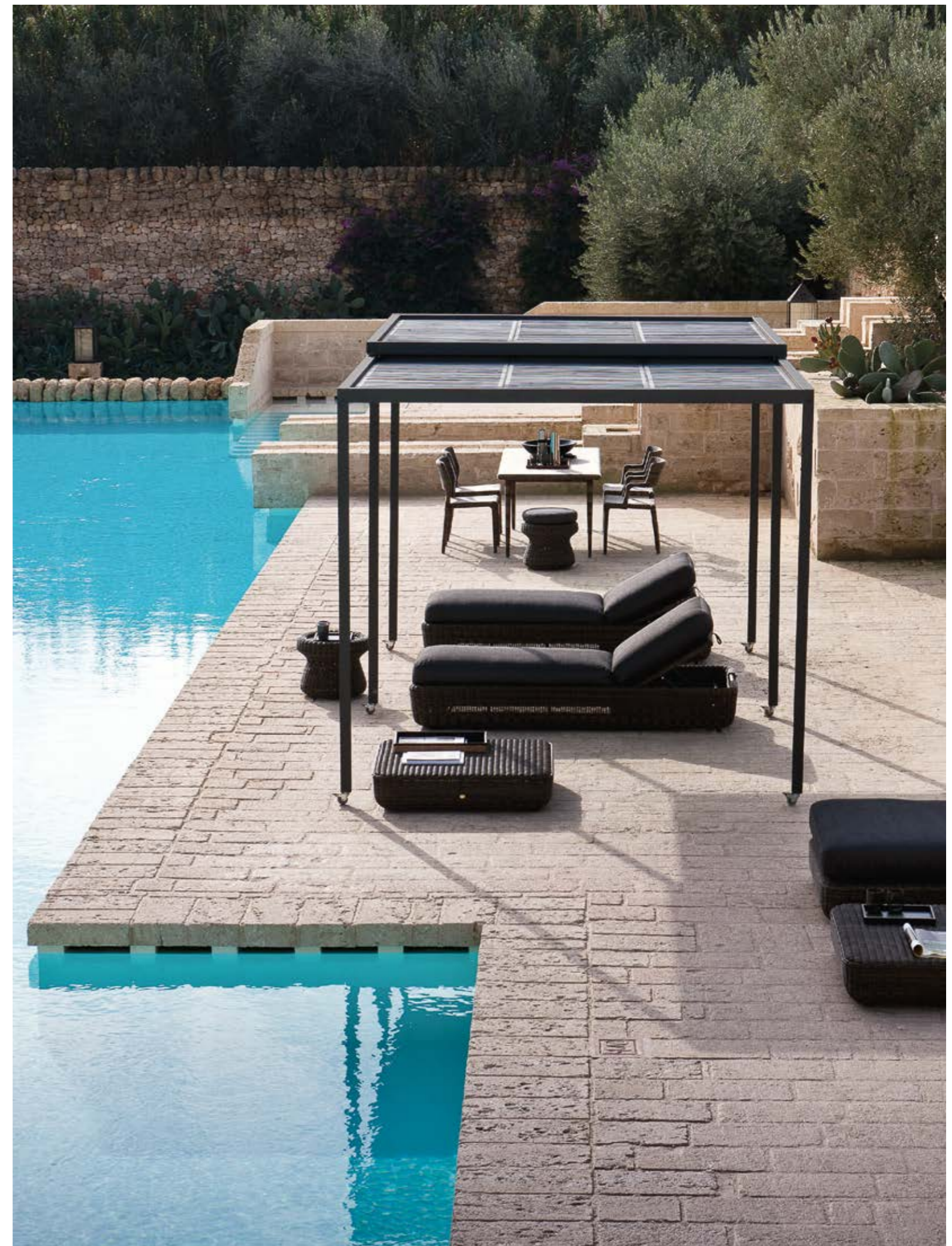



Tibisco Collection

En

Tibisco reinterprets the historic structures found in ancient Cistercian monasteries, offering a line of pergolas in a classic, traditional style. The romantic, ornamental style is conveyed by the circular patterns of the front beams, which interact harmoniously with the slim, delicate structure made from powder-coated galvanised iron.

It

Tibisco reinterpreta le storiche strutture presenti negli antichi monasteri cistercensi, proponendo una linea di pergole dallo stile classico e tradizionale. Il sapore romantico e ornamentale si distingue nei motivi circolari delle travi frontali, che dialogano armoniosamente con la struttura sottile e delicata in ferro zincato verniciato a polveri.

Fr

Tibisco réinterprète les structures historiques présentes dans les anciens monastères cisterciens et propose une ligne de pergolas au style classique et traditionnel. Le style romantique et ornemental se distingue par ses motifs circulaires des traves frontales qui complètent harmonieusement la structure fine et délicate en fer galvanisé peint revêtu de poudre.





En -
Available lean-to, self-supporting and in the form pavilion form, the collection can be complemented with decorations and semicircles in the plinths, to add details of style and timeless elegance.

It -
Disponibile addossata, autoportante e sotto forma di padiglione, la collezione può essere integrata con decori e semicerchi nei basamenti, per aggiungere dettagli di stile ed eleganza senza tempo.

Fr -
Disponibles en version autoportante sous forme de pavillon et adossée, les pergolas d'arceaux et bases décorées pour ajouter des détails de style et d'élégance intemporelle.



Solaire Collection

En -

The Solaire pergola collection stands out due to its traditional, ornamental style, which is reminiscent of the classical lines of historic Italian garden architecture. Its characteristics make it an intermediate indoor/outdoor complement suited to every home, with which it generates a harmonious dialogue. Its timeless style makes it the ideal complement to the historic Unopiù lines.

It -

La collezione di pergole Solaire si distingue per il sapore tradizionale ed ornamentale, che richiama lo stile classico delle storiche architetture dei giardini all'italiana. La sua funzione la rende un complemento intermedio tra interno ed esterno necessario per ciascuna abitazione, con cui genera un armonioso dialogo. Il suo stile senza tempo la rende il completamento ideale delle storiche linee di Unopiù.

Fr -

La collection de pergolas Solaire se distingue par son caractère traditionnel et ornemental qui rappelle le style classique des architectures historiques des jardins à l'italienne. La pergola est un élément intermédiaire entre l'extérieur et l'intérieur de la maison, avec laquelle elle instaure un dialogue harmonieux. Son style intemporel en fait un complément idéal des lignes historiques d'Unopiù.



En -

The solid frame in powder-coated galvanised iron becomes a decorative element and is available on all models: wall-mounted, free-standing or in the form of a pavilion with a round or octagonal floorplan. The many coverings, available in various finishes, adapt to all the different types, completing the product with sophistication and elegance.

It -

Lo scheletro solido in ferro zincato verniciato a polveri diventa elemento decorativo ed è disponibile in tutti i modelli: addossata, autoportante e sotto forma di padiglione a pianta rotonda o ottagonale. Le molteplici coperture, disponibili in diverse finiture si adattano a tutte le tipologie, completando con raffinatezza ed eleganza il prodotto.

Fr -

La structure solide en fer galvanisé peint revêtu de poudre devient un élément décoratif. Il est disponible dans tous les modèles : adossée, autoportante et sous forme de pavillon rond ou octogonal. Les couvertures, proposées avec diverses finitions, s'adaptent à tous les types de structure et y apportent une touche de raffinement et d'élégance.





Lipari Collection

En -

The Lipari parasol collection is designed to complete and customize outdoor spaces by combining practicality and functionality with elegant aesthetics. The fabric covering, available in various colors, is water-repellent and resistant to fading caused by U.V. rays. Available in various sizes and finishes, Lipari allows the utmost freedom to create and choose the best solution.

It -

Una collezione di ombrelloni pensata per completare e personalizzare gli spazi esterni, coniugando praticità e funzionalità a un'elegante estetica. Il telo in tessuto è idrorepellente e resistente allo sbiadimento dovuto all'azione dei raggi U.V. Disponibile in numerose dimensioni e finiture, la linea Lipari lascia la massima libertà di comporre e scegliere la soluzione migliore, in base alle proprie esigenze.

Fr -

Une collection de parasols conçue pour compléter et personnaliser les espaces extérieurs, alliant praticité et fonctionnalité à une esthétique élégante. La toile en tissu acrylique est hydrofuge et résistante à la décoloration due à l'action des rayons U.V. Disponible dans de nombreuses dimensions et finitions, la ligne Lipari laisse la plus grande liberté pour composer et choisir la meilleure solution en fonction de vos besoins.



En -

The materials range from ash wood to the central pole made from beech or aluminum, the base made from stone, stainless-steel or galvanized iron, right up to a circular base made from concrete and an adjustable iroko wood top, designed by Studio Adolini.

It -

I materiali variano dal legno di frassino o di faggio, all'alluminio per il palo centrale, alla base in pietra, acciaio inox o ferro zincato fino ad una base circolare con struttura in cemento e ripiano in legno di iroko regolabile, disegnata dallo Studio Adolini.

Fr -

Les matériaux utilisés sont très variés. On peut y trouver un mât central en bois de frêne, ou en aluminium, un socle en pierre, ou en fer galvanisé, et une base circulaire en béton dotée d'une étagère en bois d'iroko réglable, conçue par Studio Adolini.

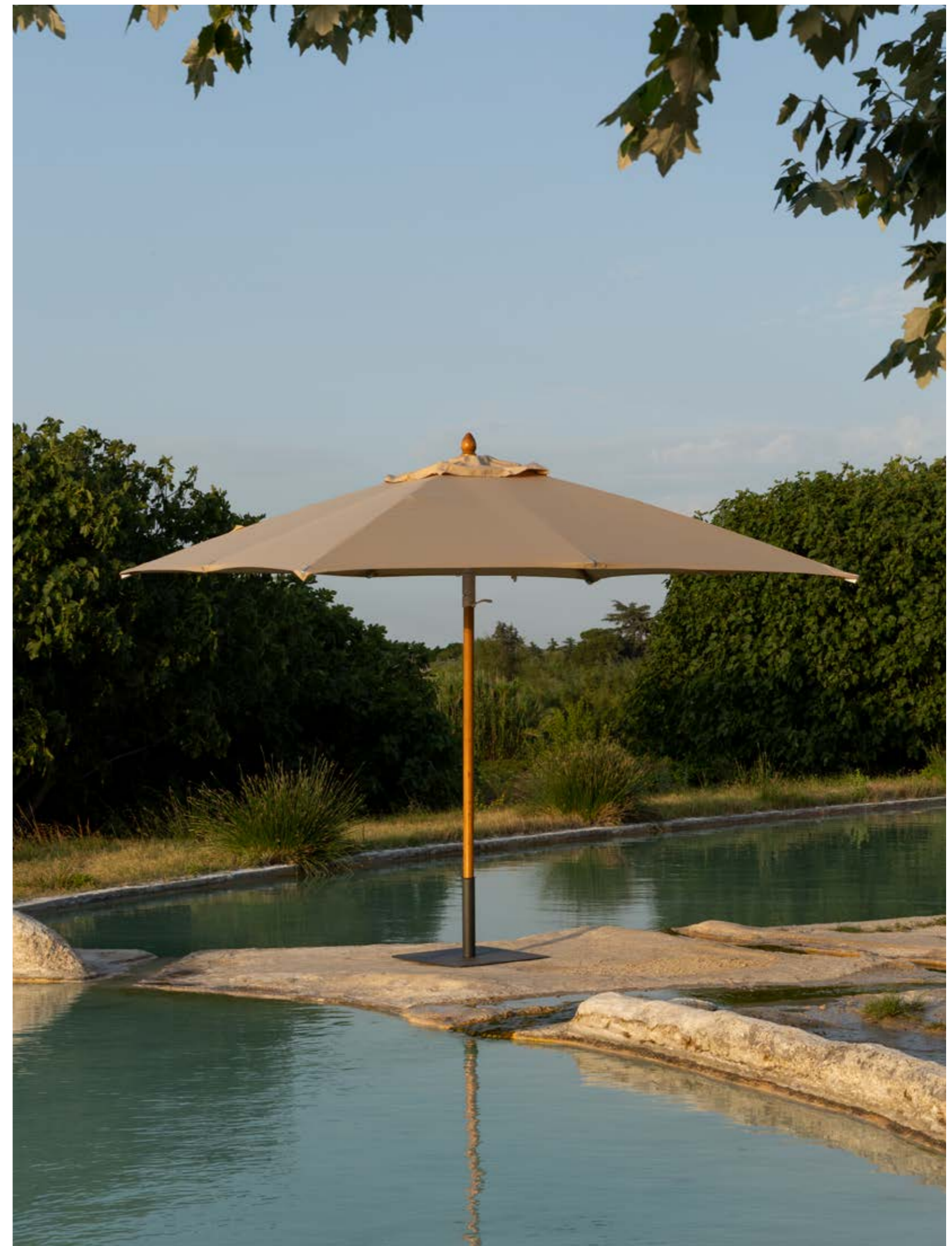

Salento Collection



En -

Salento is a collection of parasols with a contemporary style, featuring a practical lateral support pole. The opening of the awning is available in both motorised and manual versions, to meet different functional and aesthetic needs.

General catalogue

It -

Salento è una collezione di ombrelloni dallo stile contemporaneo, caratterizzati dal pratico palo di sostegno laterale. L'apertura della tenda da sole è disponibile sia motorizzata che manuale, per rispondere alle diverse esigenze funzionali ed estetiche.

Fr -

Salento est une collection de parasols au style contemporain, caractérisés par un mât de soutien latéral très pratique. L'ouverture de la toile est disponible en version motorisée ou manuelle pour répondre aux diverses exigences fonctionnelles et esthétiques.

249



En -

The base is designed to be used with concrete tiles, sold separately from the structure, which guarantee the equilibrium and balance of the product without invading the space below the covering.

It -

La base è pensata per poter accogliere le piastrelle in cemento che garantiscono l'equilibrio e il bilanciamento del prodotto senza invadere lo spazio sottostante alla copertura.

Fr -

La base est conçue pour pouvoir accueillir les contrepoids en béton qui garantissent l'équilibre du produit sans empiéter sur l'espace abrité par la couverture.

Damian Collection

Design by
Andreucci & Hoisl



En -

The new Damian outdoor parasol by Unopiù brings to mind time spent relaxing and warm elegance with a colonial feel: the structure is entirely made of ash wood. This large parasol is made of acrylic fabric which is resistant to stains, salt and UV rays, and comes in a square or round version. Created by hand, Damian has a rope opening and refined and sophisticated details such as the leather hub runner with visible stitching. Damian is available in the version with brown leather hub runner and ecru cloth with brown piping, or with navy blue leather hub runner and ecru cloth with blue piping. This new versatile outdoor furnishing by Unopiù is ideal for the garden, terrace, beach, boats and poolside.

It -

Il nuovo ombrellone da esterno Damian di Unopiù porta alla mente momenti di relax e un'eleganza calda dal sapore coloniale: la struttura è interamente in legno di frassino. Il grande ombrellone è realizzato in tessuto acrilico resistente alle macchie, alla salsedine e all'azione dei raggi UV, disponibile in versione quadrata o rotonda. Realizzato artigianalmente, Damian ha un'apertura tramite corda e dettagli raffinati e sofisticati come il muscolo in pelle con cucitura a vista. Damian è disponibile nella versione con muscolo in pelle marrone e telo écru con piping marrone, oppure con muscolo in pelle blu navy e telo écru con piping blu. Un nuovo, versatile arredo da esterni firmato Unopiù, ideale per giardino, terrazzo, spiaggia, barche e bordo piscina.

Fr -

Le nouveau parasol Damian d'Unopiù porte à l'esprit des moments de détente et une élégance chaleureuse : la structure est entièrement en bois de frêne. La grande toile est réalisée en tissu acrylique résistant aux taches, au sel et à l'action des rayons UV et disponible en version carrée ou ronde. Fabriqué à la main, Damian a une ouverture manuelle avec corde et des détails raffinés et sophistiqués tels que le coulant en cuir avec couture apparente. Damian est disponible dans la version avec coulant en cuir marron et toile écru avec passepoil marron, ou avec coulant en cuir bleu marine et toile écru avec passepoil bleu. Un nouveau mobilier d'extérieur polyvalent signé Unopiù, idéal pour jardin, terrasse, plage, bateaux et piscine.



Orangerie Collection

En -

Orangerie is a classically inspired greenhouse system made from galvanised and powder-coated iron with a polycarbonate covering designed to recreate a green environment that is ideal for growing and nurturing plants outside their natural environment.

It -

Orangerie è un sistema di serre d'ispirazione classica, in ferro zincato e verniciato a polveri con copertura in polycarbonato pensata per ricrearsi un'ambiente verde, ideale per coltivare e prendersi cura delle piante fuori dal loro ambiente naturale.

Fr -

Orangerie est une serre d'inspiration classique en fer galvanisé peint revêtu de poudre. Dotée d'une couverture en polycarbonate, elle permet de recréer un espace vert idéal pour cultiver et prendre soin des plantes en dehors de leur environnement naturel.



En ~

Offered in two models, free-standing and wall-mounted, it can adapt to any space. The structure features large polycarbonate surfaces, which are effective at allowing natural, continuous lighting inside. Most of them can be opened to allow the regulation of air flow and to ensure ventilation for the plants.

It ~

Proposta in due modelli, autoportante e addossata, è capace di soddisfare ogni esigenza di spazio. La struttura è caratterizzata da ampie superfici in polycarbonato, efficaci per permettere una naturale e costante illuminazione all'interno. La maggior parte di esse sono apribili, per consentire la regolazione dell'aria e garantire la ventilazione delle piante.

Fr ~

Proposée en deux modèles, autoportante et adossée, elle répond à tous les besoins en terme d'espace. La structure se caractérise par de grandes surfaces en polycarbonato qui permettent d'obtenir un éclairage naturel et constant à l'intérieur. La plupart des modèles sont ouvrables, ce qui assure une régulation de l'air et une bonne ventilation des plantes.





Manta Collection

En -

Manta is a sail with an architectural connotation, designed to generate shaded spaces with practicality and simplicity.

General catalogue

It -

Manta è una vela dalla connotazione architettonica, pensata per generare spazi d'ombra con praticità ed essenzialità.

Fr -

Manta est une voile à connotation architecturale conçue pour créer des espaces ombragés de manière très pratique et simple.

259

En -

Its structure of Nordic pine in Bangkirai colour combined with PVC coated fabric for the hexagonal shape and acrylic for the rhomboid shape is certified to withstand winds with an intensity of up to 50 km per hour.

It -

La sua struttura composta da pino nordico color Bangkirai combinato al tessuto spalmato di PVC per la forma esagonale, e acrilico per la forma romboidale è certificata per la resistenza a venti di intensità sino a 50 km orari.

Fr -

Sa structure, composée de pin nordique de couleur Bangkirai, se combine à une toile enduite de PVC pour la forme hexagonale et acrylique pour la forme en losange, et elle garantit une résistance à des vents d'une intensité allant jusqu'à 50 km / heure.





Nagi Collection

En

Nagi is a complete system of outdoor structures that can be customised with the utmost freedom, made of impregnated Nordic pine wood in Bankirai or white colour to ensure solidity and durability. Inspired by Japanese aesthetics, the modern circular section profiles instill a sense of airiness and the grids with their geometric striped, diagonal or perpendicular patterns create a balanced play of light and shadow, of full and empty spaces, lending it a sophisticated, contemporary feel.

It

Nagi è un sistema completo di strutture per l'outdoor da personalizzare con massima libertà, realizzato in legno di pino nordico impregnato color Bankirai o bianco per garantire solidità e durevolezza. Ispirato all'estetica giapponese, i profili moderni a sezione circolare infondono un senso di grande leggerezza e i grigliati dai motivi geometrici a righe, diagonali o perpendicolari creano un equilibrato gioco di luci e ombre, pieni e vuoti, donandole un'aria raffinata e contemporanea.

Fr

Nagi est un système complet de structures pour extérieur à personnaliser en toute liberté, réalisé en pin nordique traité de couleur Bankirai ou blanc qui assure solidité et durabilité. Inspiré de l'esthétique japonaise, les profils modernes à section ronde apportent une impression de grande légèreté. Les treillis aux motifs géométriques à rayures, diagonaux ou perpendiculaires créent un jeu d'ombre et de lumière, de pleins et de vides, et confèrent un style raffiné et contemporain.

En -

The structure offers the utmost compositional freedom, allowing the creation of tailor-made solutions, both wall-mounted and freestanding, according to the various needs.

It -

La struttura offre la massima libertà compositiva, dando la possibilità di creare soluzioni su misura, adossate o autoportanti, in base alle diverse esigenze.

Fr -

La structure offre une liberté de composition optimale et permet de créer des solutions sur mesure, adossées ou autoportantes, en fonction des diverses exigences.

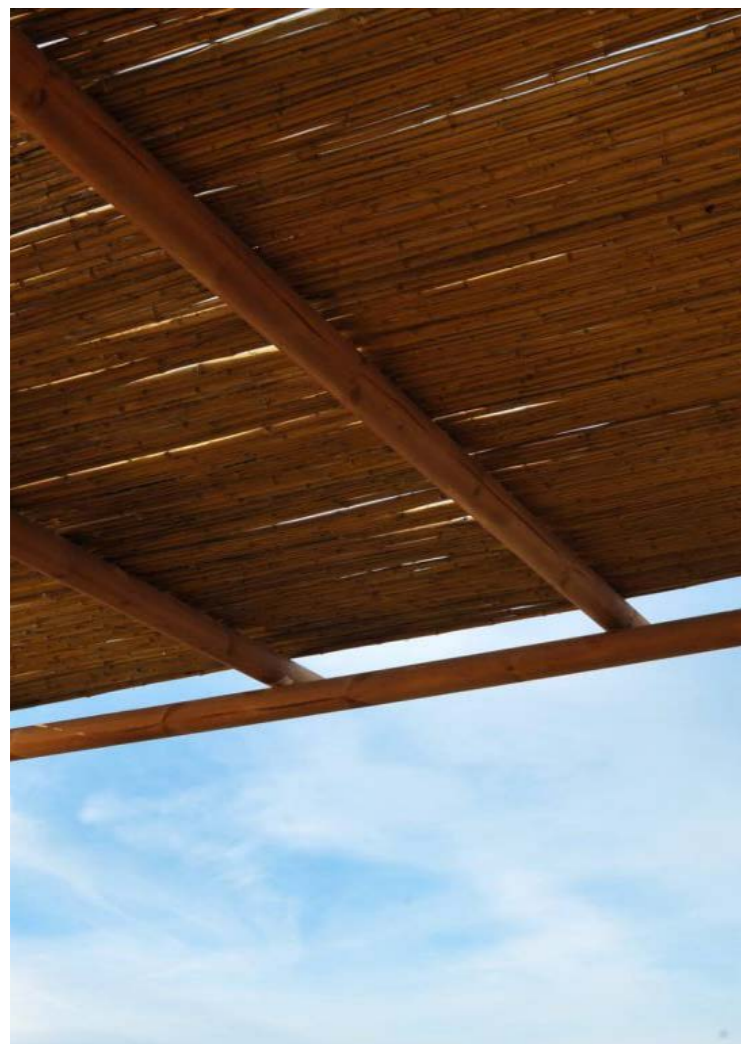

Levante Collection



266

En -

Levante garden umbrella features the Motion Mechanical Opening System which facilitates its use, making it intuitive, practical and lightweight. The solid base and side arm guarantees a secure anchoring stability and provide a pleasant, and newly restored look, which can diffuse shade to the underlying areas.

General catalogue

It -

L'ombrellone Levante è caratterizzato dal sistema di apertura meccanica Motion, che ne facilita l'utilizzo, rendendolo intuitivo, pratico e leggero. La solida base e il braccio laterale ne assicurano l'ancoraggio e garantiscono all'ambiente sottostante una piacevole ombra diffusa.

Fr -

Le parasol Levante est équipé du système d'ouverture mécanique Motion, qui facilite son utilisation, le rendant à la fois intuitif, pratique et léger. La base solide et le bras latéral assurent son ancrage et fournissent à l'environnement sous-jacent une ombre diffuse agréable.

267

Riviera Collection



En -

Joining the collection is the Riviera umbrella, an elegant round umbrella with a 100% acrylic canopy, available in olive green and raw white with an ecru contrasting border. With its classic style, it is the ideal solution for contract settings, combining practicality and sophistication.

It -

Entra a far parte della collezione, l'ombrellone Riviera, un elegante ombrellone rotondo con telo 100% acrilico, disponibile nelle colorazioni verde oliva e bianco grezzo con bordino a contrasto ecru. Dallo stile classico, è la soluzione ideale per contesti contract, combinando praticità e raffinatezza.

Fr -

Faisant partie de la collection, le parasol Riviera est un élégant parasol rond avec toile 100% acrylique, disponible dans les coloris vert olive et blanc brut avec un bord contrasté écru. D'un style classique, il est la solution idéale pour les environnements contractuels, alliant praticité et raffinement.



Covercar Collection

En

The coverings made specially for cars are handcrafted from impregnated Nordic pine in Bangkirai or white color, a wood capable of withstanding all atmospheric agents and temperatures.

It

Le coperture dedicate alle auto sono realizzate artigianalmente in pino nordico impregnato color Bangkirai o bianco un legno resistente a tutti gli agenti atmosferici e temperature.

Fr

Les abris de voiture de fabrication artisanale sont composés de pin nordique imprégné de couleur Bangkirai ou blanc, un bois résistant à tous les agents atmosphériques, quelles que soient les températures.



Dafne Collection



274

En

Its perimeter decoration made from graphite-coloured powder-coated galvanised iron makes the traditionally styled Dafne projecting roof stand out. Extensions make it possible to configure the best solution for every need. The embossed polycarbonate covering is an excellent solution for sheltering from bad weather.

General catalogue

It

La pensilina Dafne dal sapore tradizionale, si distingue per il decoro perimetrale realizzato in ferro zincato verniciato a polveri color grafite. Le estensioni permettono di configurare a piacere la soluzione migliore in base ad ogni esigenza. La copertura in polycarbonato gofrato è un'ottima soluzione per riparare dalle intemperie.

Fr

Le auvent Dafne de style traditionnel se distingue par le design soigné de sa décoration latérale, réalisée en fer galvanisé peint revêtu de poudre de couleur graphite. Les extensions permettent d'obtenir la configuration la mieux adaptée en fonction des besoins. La couverture en polycarbonate gaufré offre une solution parfaite pour se protéger des intempéries.

275



En -

The canopy boasts different shapes and sizes: a flat one with rounded ends measuring 217x60 cm or 317x60 cm with the option of extending up to 201 or 301 cm; and a more geometric and square-shaped one with a length of 240, 280 or 320 cm and a height of 104 cm.

It -

La pensilina vanta diverse forme e dimensioni: una piatta con estremità arrotondate di 217x60 cm o 317x60 cm con possibilità di estensione fino a 201 o 301 cm; e una più geometrica e squadrata dalla lunghezza di 240, 280 o 320 cm e altezza di 104 cm.

Fr -

L'auvent se décline sous différentes formes et dimensions : plat aux extrémités arrondies mesurant 217x60 cm ou 317x60 cm avec possibilité d'extension jusqu'à 201 ou 301 cm ; et un plus géométrique et à trois pentes avec une longueur de 240, 280 ou 320 cm et une hauteur de 104 cm.



05.

Egadi
Symi
Syros
Pouf
Rugs
Vases
Portofino
Solare
Jolly Cushions

Egadi

Design by
Andrea Steidl



En

Made of fibre with a glossy glazed finish, designed for outdoor use, these side tables come as a pair of complementary volumes: one cylindrical, the other a truncated pyramid, joined by a clean line that marks the meeting point of the two geometries. Available in two sizes and in refined shades of chocolate, dove, stone, and terracotta, they convey a strong sense of materiality and a sculptural presence.

It

Realizzati in fibra con finitura smaltata lucida e pensati per l'outdoor, i tavolini si presentano in una coppia di due volumi che si completano a vicenda: uno cilindrico, l'altro a tronco di piramide, uniti da una linea netta che segna il punto d'incontro tra le due geometrie. Disponibili in due dimensioni e nelle raffinate tonalità cioccolato, dove, stone e terracotta, esprimono una forte matericità e una presenza scultorea.

Fr

Réalisés en fibre avec une finition émaillée brillante, conçus pour l'extérieur, ces petites tables se présentent en duo de volumes complémentaires: l'un cylindrique, l'autre en tronc de pyramide, reliés par une ligne nette qui marque le point de rencontre entre les deux géométries. Disponibles en deux dimensions et dans les teintes raffinées chocolat, dove, stone et terracotta, elles expriment une forte matérialité et une présence sculpturale.

Symi

Design by
Gianpaolo Venier



En -

Symi is a collection of coffee tables designed by Gianpaolo Venier, available in two sizes. The teak structure is paired with a textured top in the refined Stone and Dove finishes. Elegant and natural, Symi coffee tables are designed to enhance any outdoor setting with warmth and understated sophistication.

It -

Symi è una collezione di coffee table disegnata da Gianpaolo Venier, disponibile in due dimensioni. La struttura in teak si abbina a un piano materico proposto nei raffinati colori Stone e Dove. Eleganti e naturali, i coffee table Symi sono pensati per arricchire ogni ambiente outdoor con un tocco di calore e sobria ricercatezza.

Fr -

Symi est une collection de coffee tables dessinée par Gianpaolo Venier, disponible en deux dimensions. La structure en teck est associée à un plateau texturé, décliné dans les tons élégants Stone et Dove. Naturelles et raffinées, les coffee tables Symi apportent une touche chaleureuse et sophistiquée à tous les espaces extérieurs.

Syros

Design by
Gianpaolo Venier



En

Syros is an iron side table, available in elegant Graphite and Terracotta finishes. Designed by Gianpaolo Venier, it combines aesthetics and functionality in a versatile piece, created to enhance any outdoor setting. Lightweight, durable, and easy to move, Syros fits seamlessly into terraces, gardens, verandas, and poolside areas.

It

Syros è un tavolino ausiliario in ferro, disponibile nelle eleganti finizioni Antracite e Terracotta. Disegnato da Gianpaolo Venier, unisce estetica e funzionalità in un complemento versatile, pensato per valorizzare ogni ambiente outdoor. Leggero, resistente e facile da spostare, Syros si adatta con naturalezza a terrazze, giardini, verande e spazi a bordo piscina.

Fr

Syros est une table d'appoint en fer, disponible dans les élégantes finitions Anthracite et Terracotta. Dessinée par Gianpaolo Venier, elle allie esthétique et fonctionnalité dans un meuble polyvalent, conçu pour sublimer tous les espaces extérieurs. Légère, résistante et facile à déplacer, Syros s'intègre naturellement aux terrasses, jardins, vérandas et espaces au bord de la piscine.

Pouf



En -

The new rope pouf, available in anthracite grey and light gray, with a diameter of 50 cm and compact dimensions, is a versatile piece that fits any setting, perfect for completing and enriching any space with elegance and functionality.

It -

Il nuovo pouf in corda, disponibile nelle varianti grigio antracite e grigio chiaro, con un diametro di 50 cm e dimensioni compatte, è un elemento versatile che si adatta a ogni contesto, perfetto per completare e arricchire qualsiasi spazio con eleganza e funzionalità.

Fr -

Le nouveau pouf en corde, disponible dans les variantes gris anthracite et gris clair, avec un diamètre de 50 cm et des dimensions compactes, est un élément polyvalent qui s'adapte à tous les contextes, idéal pour compléter et enrichir n'importe quel espace avec élégance et fonctionnalité.



Rugs

En -

Unopiù presents two new outdoor rugs with exclusive designs, created to enhance outdoor spaces with elegance and durability. The striped rug in ecru and terracotta combines subtle lines in warm tones, perfectly in tune with the furnishings, creating a harmonious and refined atmosphere. The graphite and ecru rug, on the other hand, thanks to its sophisticated weave, offers a color contrast that adds character and style to outdoor spaces.

It -

Unopiù presenta due nuovi tappeti outdoor dal design esclusivo, pensati per arricchire gli spazi esterni con eleganza e resistenza. Il tappeto rigato in ecru e terracotta combina linee sottili in tonalità calde, perfettamente in sintonia con gli arredi, creando un'atmosfera armoniosa e raffinata. Il tappeto intrecciato grafite ed ecru invece, grazie al suo intreccio sofisticato, offre un contrasto di colori che conferisce carattere e stile agli ambienti esterni.

Fr -

Unopiù présente deux nouveaux tapis outdoor au design exclusif, pensés pour enrichir les espaces extérieurs avec élégance et résistance. Le tapis rayé en écru et terracotta combine des lignes subtiles dans des tons chauds, parfaitement en harmonie avec les meubles, créant une atmosphère harmonieuse et raffinée. Le tapis graphite et écru, quant à lui, grâce à son tissage sophistiqué, offre un contraste de couleurs qui apporte caractère et style aux espaces extérieurs.

En -

Both are made with high-quality materials, designed to ensure resistance and long-lasting performance, even in the harshest outdoor conditions.

It -

Entrambi sono realizzati con materiali di alta qualità, progettati per garantire resistenza e prestazioni durature, anche nelle condizioni esterne più difficili.

Fr -

Les deux sont fabriqués avec des matériaux de haute qualité, conçus pour garantir résistance et performance durable, même dans les conditions extérieures les plus exigeantes.

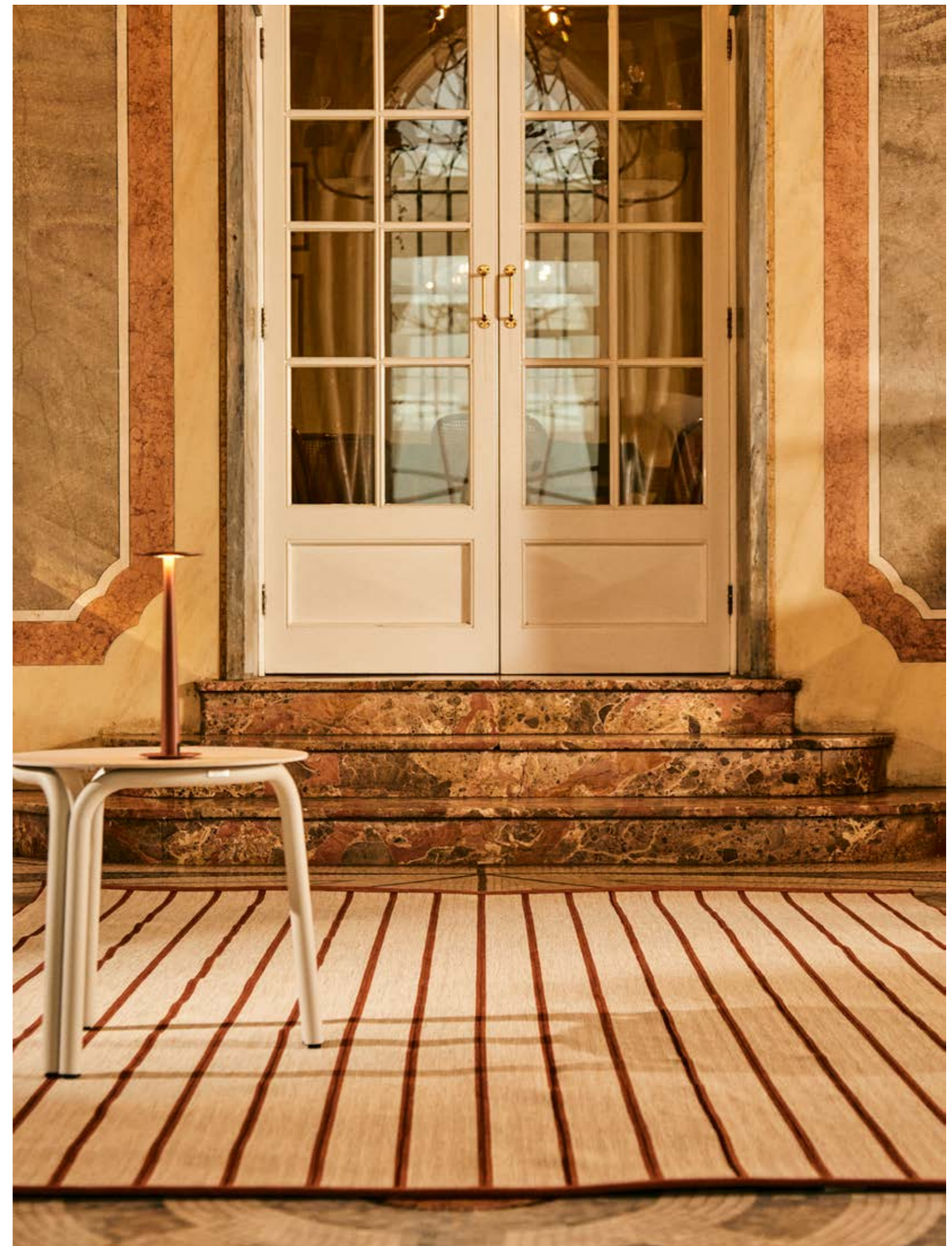



Vases

En -

Essential accessories to complete the outdoors, Unopiù vases are characterised by discreet shapes and classic colours, so that the surrounding environment may be decorated without sacrificing style.

It -

Complementi immancabili per completare l'outdoor, i vasi Unopiù sono caratterizzati da forme discrete e colori classici, per permettere di corredare l'ambiente che li ospita senza rinunciare allo stile.

Fr -

Éléments incontournables pour compléter les espaces extérieurs, les vases Unopiù se caractérisent par leurs formes discrètes et leurs couleurs classiques, qui permettent de les coordonner à l'environnement sans renoncer au style.

Portofino



En -

The Portofino table lamp, designed by Valerio Sommella for Nemo, comes to life in an exclusive terracotta version thanks to the collaboration with Unopiù. Light and compact, it is perfect for illuminating the dining and lounge areas, both indoors and outdoors, creating a cozy atmosphere while combining elegance and functionality.

It -

La lampada da tavolo Portofino, firmata da Valerio Sommella per Nemo, prende vita in una versione esclusiva color terracotta grazie alla collaborazione con Unopiù. Leggera e compatta, è perfetta per illuminare la zona dining e lounge, sia all'interno che all'aperto, creando un'atmosfera accogliente e unendo eleganza e funzionalità.

Fr -

La lampe de table Portofino, signée par Valerio Sommella pour Nemo, prend vie dans une version exclusive couleur terracotta grâce à la collaboration avec Unopiù. Légère et compacte, elle est parfaite pour éclairer la zone dining et lounge, à l'intérieur comme à l'extérieur, créant une atmosphère chaleureuse et alliant élégance et fonctionnalité.

Solare Collection



En -

Solare is a collection of lamps and lanterns where the versatility of the lines is expressed through materials, colours and shapes designed to respond to various functional and aesthetic needs. All the models share the same light source: an LED solar panel integrated into the structure that is rechargeable and adjustable in terms of intensity and diffuses an intense light that transforms any room into a warm, domestic landscape.

It -

Solare è una collezione di lampade e lanterne dove la versatilità delle linee si esprime attraverso materiali, colori e forme immaginate per rispondere a diverse esigenze funzionali ed estetiche. Ciò che unisce tutti i modelli è la fonte luminosa: il LED a pannelli solari integrato nella struttura, ricaricabile e regolabile nell'intensità, diffonde una luce intensa che trasforma ciascun ambiente in un caldo paesaggio domestico.

Fr -

Solare est une gamme de lampes et de lanternes présentant une grande variété de lignes à travers les matériaux, les couleurs et les formes, conçus pour répondre à diverses exigences fonctionnelles et esthétiques. Le point commun de tous ces modèles est la source lumineuse : le panneau solaire LED intégré à la structure, rechargeable et à l'intensité réglable, diffuse une lumière intense qui transforme tous les lieux en un cadre chaleureux et intime.

En -

Solare lanterns made of natural teak wood have been designed in two different styles and can be enjoyed in different settings to illuminate the area, while creating a warm and relaxing atmosphere in outdoor spaces through an enveloping light. The adjustable LED light allows you to create an intimate and relaxing atmosphere, while the handle enables them to be mounted and easily moved from one place to another.

It -

Le lanterne Solare in legno di teak naturale sono state progettate in due diverse forme e possono essere collocate in diversi ambienti per illuminare e riscaldare gli spazi outdoor attraverso una luce avvolgente. Il LED regolabile consente di creare un'atmosfera intima e rilassante, la maniglia inoltre permette di appenderle e trasportarle con facilità.

Fr -

Les lanternes Solare en bois de teck, proposées sous deux formes différentes, trouveront leur place dans les environnements les plus divers. Leur lumière enveloppante éclaire les espaces extérieurs en apportant une ambiance chaleureuse. La LED réglable permet de créer une atmosphère intime et relaxante, et la poignée est très pratique pour les suspendre et les transporter facilement.



Jolly cushions Collection



En -

Jolly cushions, available in various sizes, are essential to enriching and completing all Unopiù collections with elegance and harmony. Functionality and aesthetics nevertheless allow the linings to be removed for proper maintenance and customised in the various shades of the Unopiù colour collection.

It -

I cuscini Jolly, disponibili in diversi formati, sono indispensabili per arricchire e completare con eleganza ed armonia tutte le collezioni Unopiù. Funzionalità ed estetica si distinguono nella possibilità di sfoderarli per permetterne la corretta manutenzione, e personalizzarli nelle diverse cromie della Colour Collection Unopiù.

Fr -

Les coussins Jolly, disponibles en divers formats, sont indispensables pour enrichir et compléter avec élégance et harmonie toutes les collections Unopiù. À la fois esthétiques et fonctionnels, ils sont déhoussables, ce qui facilite leur entretien et permet de les personnaliser grâce à la vaste palette de coloris de la Colour Collection Unopiù.

En -

The use of mass-dyed technical fabrics, which are very resistant to wear and UV rays, also make the cushions perfect for indoor solutions, thanks to innovative finishing techniques that ensure the colours do not fade over time.

It -

L'utilizzo di tessuti tecnici tinti in massa, dall'alta resistenza all'usura ed i raggi UV, rendono i cuscini perfetti anche per soluzioni indoor, grazie agli innovativi trattamenti di finissaggio che garantiscono il mantenimento dei colori inalterato nel tempo.

Fr -

L'utilisation de tissus techniques teintés dans la masse, hautement résistants à l'usure et aux rayons UV, rend ces coussins parfaits également pour le mobilier d'intérieur, grâce au traitement innovant de finition qui garantit la conservation des couleurs au fil du temps.

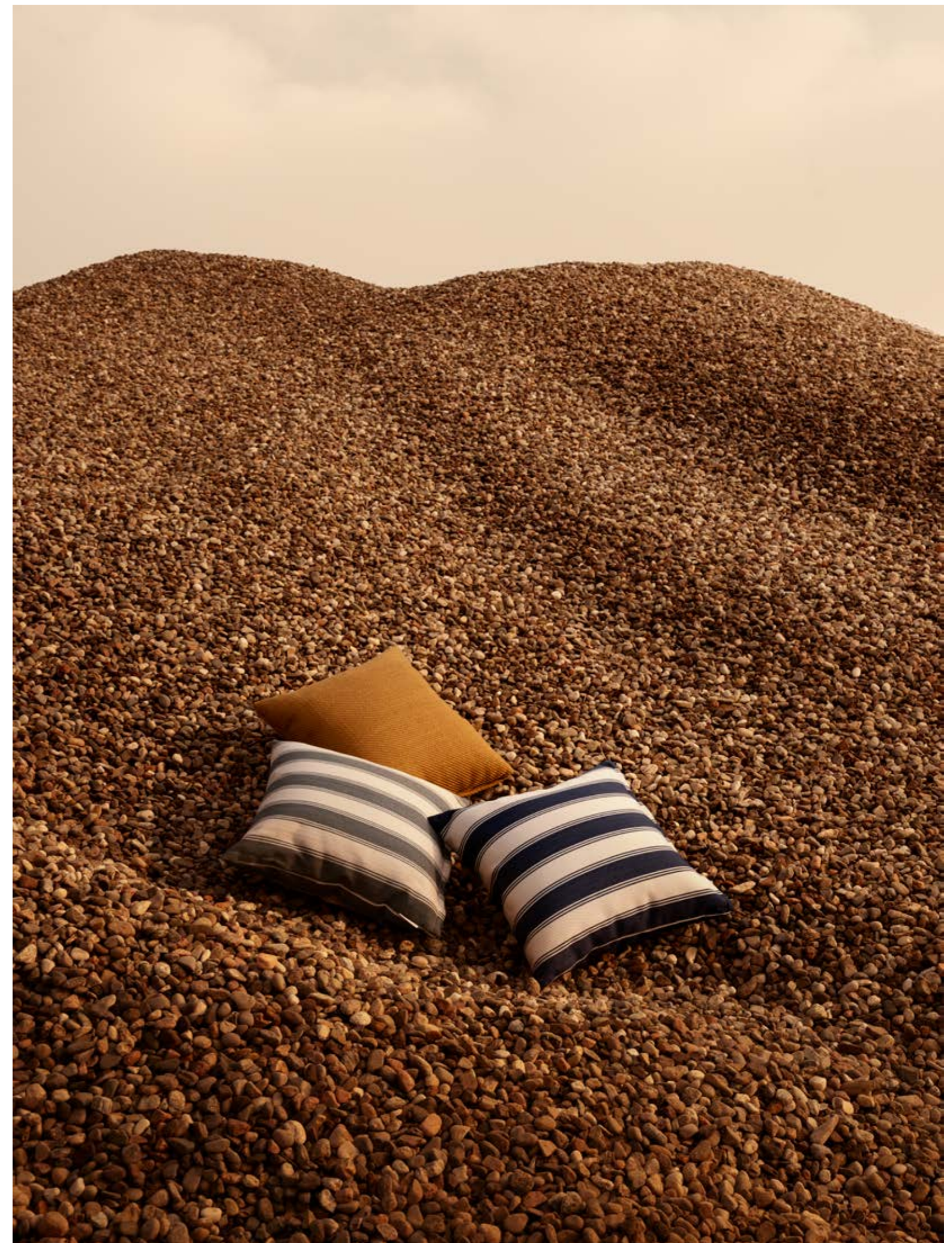



Fabrics

En -

All fabrics in the Unopiù collection are specifically designed for outdoor use. In addition to their particularly soft touch, they offer maximum resistance to UV rays and ensure long-lasting durability. A special treatment protects them from liquids and dirt, making them easy to clean with a soft sponge and neutral soap, or in the washing machine at low temperatures. In particular, the Waterproof fabrics are coated with a PVC film that makes them 100% waterproof.

It -

Tutti i tessuti della collezione Unopiù sono specifici per l'uso esterno. Oltre ad una particolare morbidezza al tatto, offrono la massima resistenza ai raggi UV e garantiscono una lunga durata. Un trattamento specifico li protegge dai liquidi e dallo sporco e li rende facili da pulire, con una spugna morbida e sapone neutro, oppure in lavatrice a basse temperature. In particolare i tessuti Waterproof sono spalmati con una pellicola di PVC che li rende impermeabili al 100%.

Fr -

Tous les tissus de la collection Unopiù sont spécialement conçus pour une utilisation en extérieur. En plus d'une douceur particulière au toucher, ils offrent une résistance maximale aux rayons UV et garantissent une longue durée de vie. Un traitement spécifique les protège des liquides et de la saleté, ce qui les rend faciles à nettoyer, soit avec une éponge douce et du savon neutre, soit en machine à basse température. En particulier, les tissus Waterproof sont enduits d'un film en PVC qui les rend 100 % imperméables.

Masterline Collection

NUVOLA by MANIFATTURA CORTI LATTE by MANIFATTURA CORTI SABBIA by SUNBRELLA

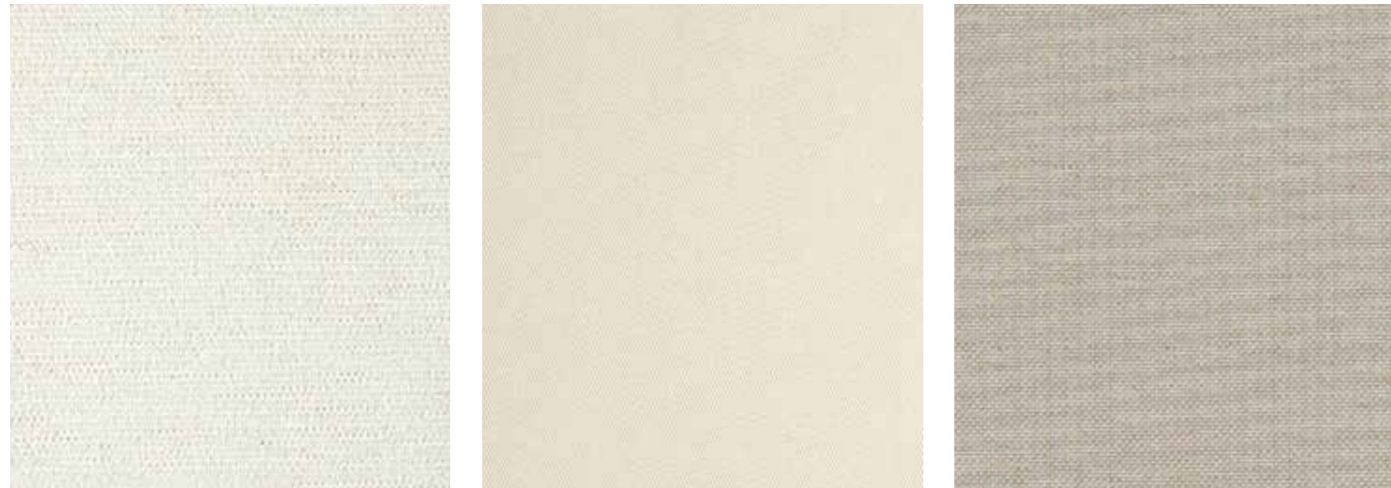

C01 ACRYLIC 360 gr/m² 04 ACRYLIC 270 gr/m² S01 ACRYLIC 290 gr/m²

BISCOTTO by MANIFATTURA CORTI NOCCIOLA by SUNBRELLA ONICE BIANCO by TUVATEXIL



153 ACRYLIC 380 gr/m² 115 ACRYLIC 275 gr/m² 147 WATERPROOF 290 gr/m²

PERLA DELICATO by CREVIN PERLA INTENSO by CREVIN CAMMEO DELICATO by CREVIN



130 WATERPROOF 390 gr/m² 120 WATERPROOF 390 gr/m² 131 WATERPROOF 390 gr/m²

Masterline Collection

CAMMEO INTENSO by CREVIN GRANITO by TUVATEXIL RAFIA DELICATO by CREVIN



121 WATERPROOF 390 gr/m² 129 WATERPROOF 290 gr/m² 186 WATERPROOF 390 gr/m²

GAROFANO by CREVIN CORTECCIA DELICATO by CREVIN BOSCO DELICATO by CREVIN



180 WATERPROOF 390 gr/m² 187 WATERPROOF 390 gr/m² 188 WATERPROOF 390 gr/m²

COBALTO DELICATO by CREVIN ARDESIA DELICATO by TUVATEXIL



189 WATERPROOF 390 gr/m² 138 WATERPROOF 390 gr/m²

Masterline Collection

STRIPES SAND by TUVATEXTIL STRIPES SUN by TUVATEXTIL STRIPES SEA by TUVATEXTIL

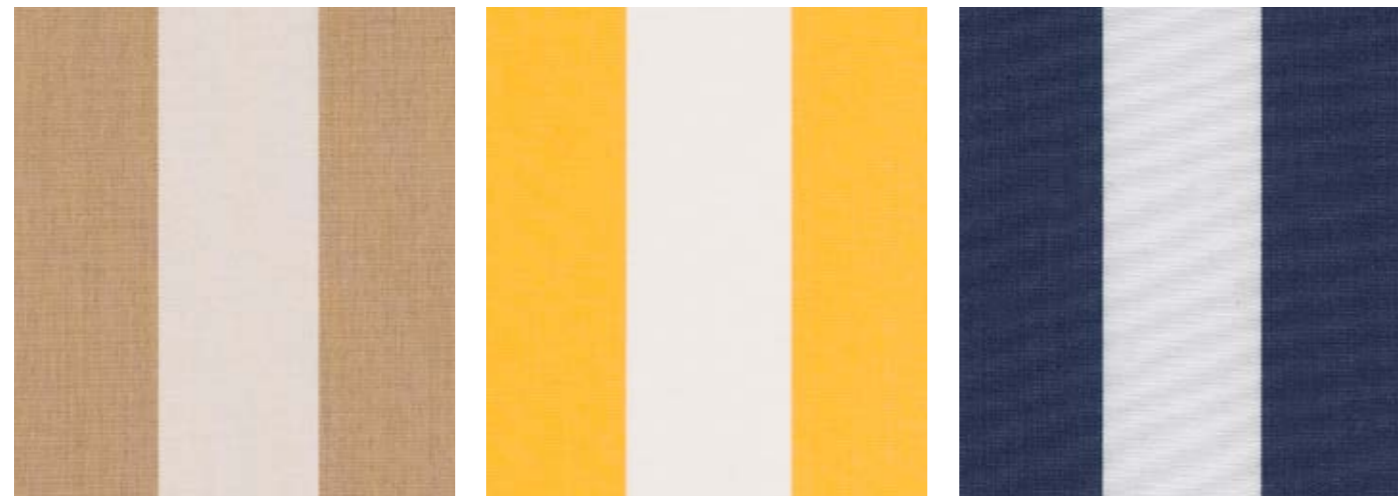

190 ACRYLIC 260 gr/m² 191 ACRYLIC 260 gr/m² 192 ACRYLIC 260 gr/m²

Essential Collection

PAPIRO by SUNBRELLA CIOTOLO by MANIFATTURA CORTI GHIAIA by MANIFATTURA CORTI



156 RECYCLED ACRYLIC 335 gr/m² 193 ACRYLIC 485 gr/m² 158 ACRYLIC 530 gr/m²

ARGILLA by MANIFATTURA CORTI GESSO by MARIA FLORA VANILLA by MARIAFLORA

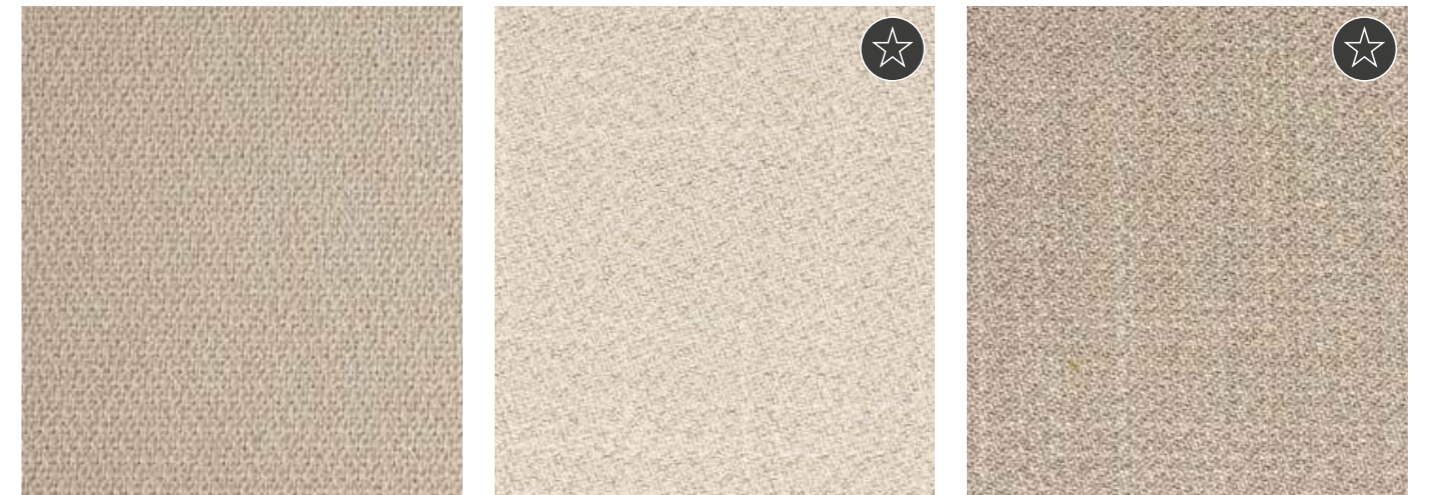

157 ACRYLIC 530 gr/m² 194 ACRYLIC 500 gr/m² 195 ACRYLIC 500 gr/m²

COTTO by SUNBRELLA MOSTO by MANIFATTURA CORTI RUST by MARIAFLORA



155 RECYCLED ACRYLIC 335 gr/m² 196 ACRYLIC 485 gr/m² 197 ACRYLIC 500 gr/m²

Essential Collection

PORFIDO by MANIFATTURA CORTI TABACCO by MARIA FLORA CINNAMON by TUVATEXIL



159 ACRYLIC 530 gr/m²



198 ACRYLIC 600 gr/m²



199 ACRYLIC 445 gr/m²

CARAMELLO by SUNBRELLA MUSCHIO by SUNBRELLA ALPE by MANIFATTURA CORTI



200 ACRYLIC 435 gr/m²



154 RECYCLED ACRYLIC 335 gr/m²



201 ACRYLIC 485 gr/m²

EUCALIPTO by MARIA FLORA OLIVINA by MANIFATTURA CORTI KENT by MARIA FLORA

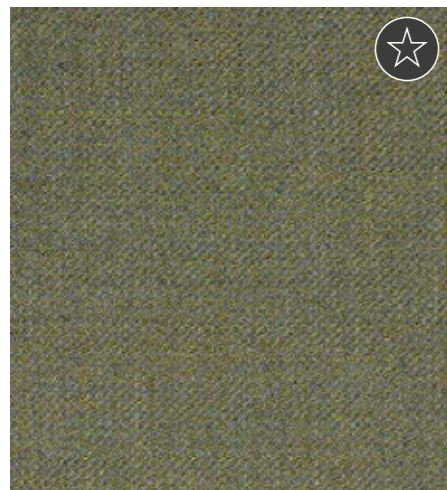

202 ACRYLIC 500 gr/m²



160 ACRYLIC 530 gr/m²



203 ACRYLIC 600 gr/m²

Essential Collection

MASAI by TUVATEXIL AGORA FONDENTE by SUNBRELLA ARIZONA by MARIA FLORA

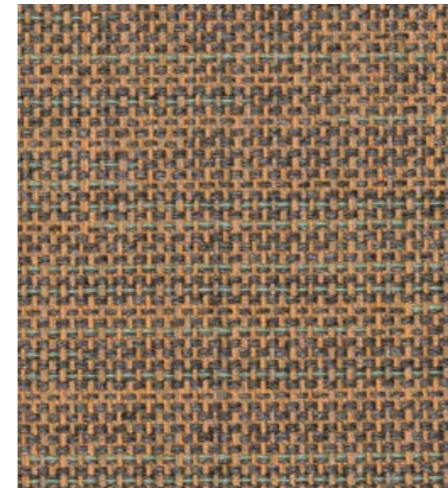

204 ACRYLIC 445 gr/m²



205 ACRYLIC 435 gr/m²

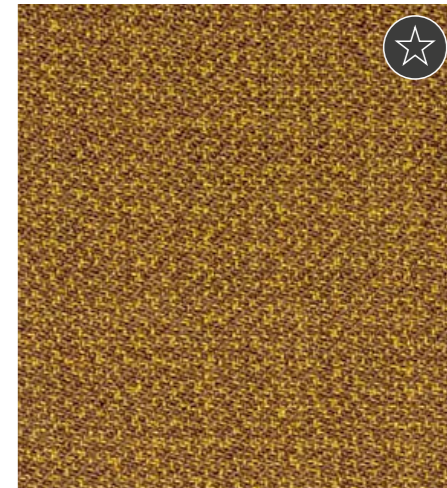

206 ACRYLIC 500 gr/m²

SENAPE MELANGE by MARIAFLORA DENIM by SUNBRELLA ARTICA by MANIFATTURA CORTI



183 ACRYLIC 450 gr/m²



185 RECYCLED ACRYLIC 335 gr/m²

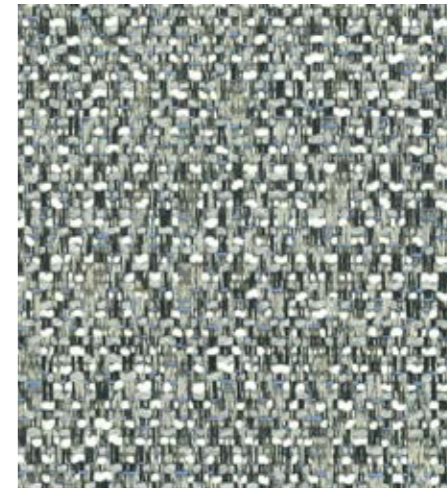

207 ACRYLIC 485 gr/m²

OCEANO by MARIA FLORA DELFT by MANIFATTURA CORTI DOVER by MARIA FLORA

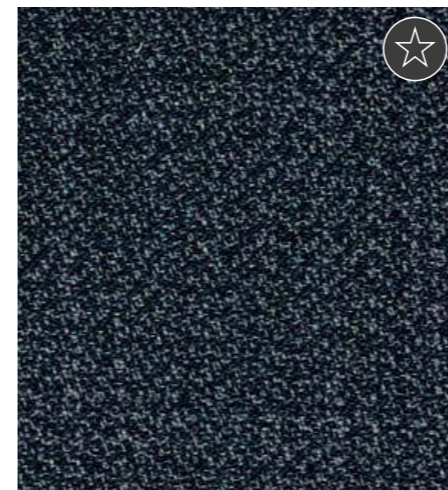

208 ACRYLIC 500 gr/m²



162 ACRYLIC 530 gr/m²



209 ACRYLIC 600 gr/m²

Essential Collection

OLTREMARE by TUVATEXIL AGORA ISCHIA by MANIFATTURA CORTI PORTOFINO by MANIFATTURA CORTI



210 ACRYLIC 445 gr/m²

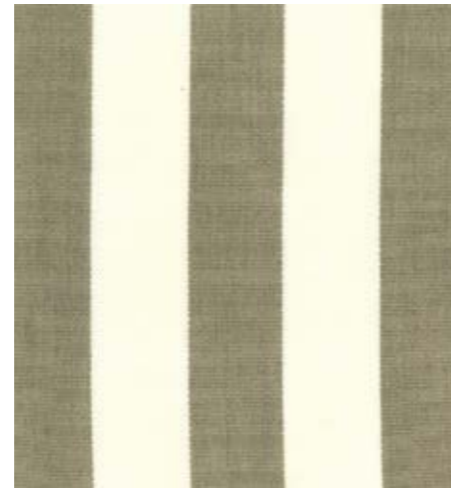

211 ACRYLIC 370 gr/m²



212 ACRYLIC 370 gr/m²

Tailored Collection

DEHORS GRIMAUD BIANCORE by LORO PIANA DEHORS GRIMAUD GINGER by LORO PIANA DEHORS BEAULIEU GINGER by LORO PIANA

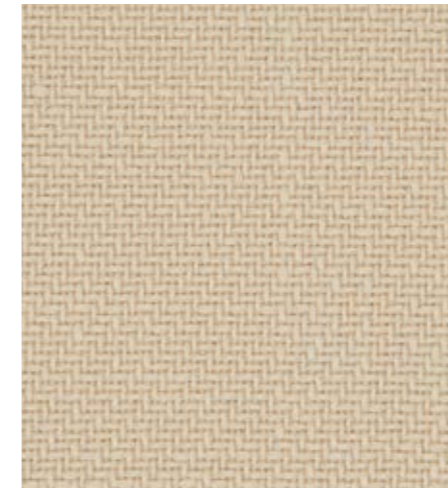

DGBIS POLYESTER 643 gr/m²



DGGIS POLYESTER 553 gr/m²



DBGIS POLYESTER 553 gr/m²

DEHORS GRIMAUD COWES by LORO PIANA

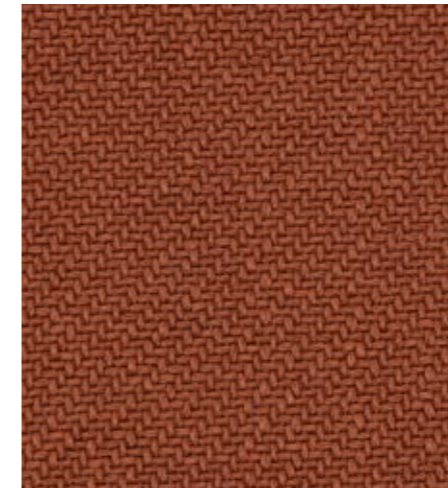

DGCOS POLYESTER 643 gr/m²

DEHORS BEAULIEU COWES by LORO PIANA



DBCOS POLYESTER 553 gr/m²

DEHORS GRIMAUD INDIGO by LORO PIANA



DGINS POLYESTER 643 gr/m²

DEHORS BEAULIEU INDIGO by LORO PIANA



DBINS POLYESTER 553 gr/m²

DEHORS GRIMAUD MALACHITE by LORO PIANA

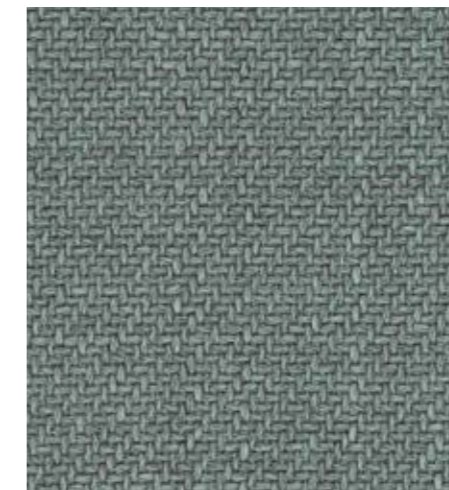

DGMAS POLYESTER 643 gr/m²

DEHORS BEAULIEU MALACHITE by LORO PIANA



DBMAS POLYESTER 553 gr/m²

Tailored Collection

DEHORS CAP FERRAT
MALACHITE by LORO PIANA



DCFMAS POLYESTER 523 gr/m²

DEHORS EZE
KUMMEL by LORO PIANA



DEKKS POLYESTER 842 gr/m²

DEHORS EZE
KASHA-MALACHITE by LORO PIANA



DEKMS POLYESTER 842 gr/m²

CIELO AZZURRO by DEDAR



YL001S POLYPROPYLENE 286 gr/m²

ROUGE MARINIERE by DEDAR



YL002S POLYPROPYLENE 286 gr/m²

CHIAROSCURO by DEDAR



YL003S POLYPROPYLENE 286 gr/m²

FORESTA by DEDAR



YL004S POLYPROPYLENE 286 gr/m²

BUCANEVE NATURALE by DEDAR



BNS POLYPROPYLENE 726 gr/m²

Tailored Collection

SUPER YACHT
STRIPE GREEN by RALPH LAUREN

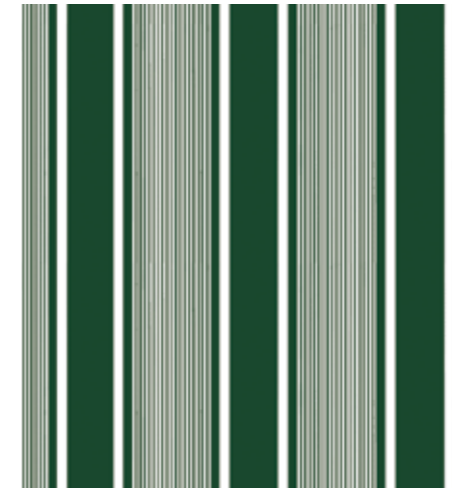

RLSYSG ACRYLIC 371 gr/m²

COURTSIDE
STRIPE GREEN by RALPH LAUREN



RLCOSG POLYESTER 265 gr/m²

CRICKET
STRIPE GREEN by RALPH LAUREN

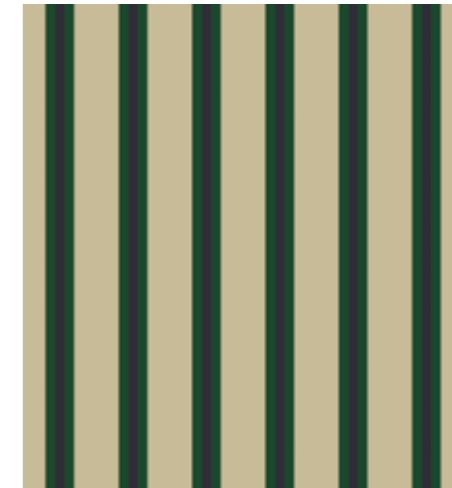

RLCRSG ACRYLIC 280 gr/m²

SUPER YACHT
STRIPE BLUE by RALPH LAUREN

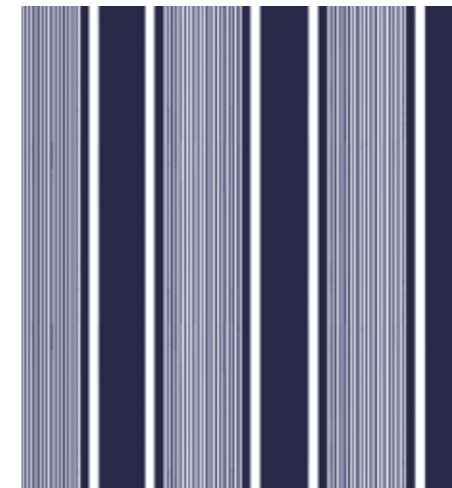

RLSYSB ACRYLIC 371 gr/m²

COURTSIDE
STRIPE BLUE by RALPH LAUREN



RLCOSB POLYESTER 265 gr/m²

FR Colour Collection

WHITE



12i

CORD



21i

DOVE GREY



19i

GREY



15i

SKY BLUE



17i

BRIGHT BLUE



18i

ACID GREEN



13i

ORANGE



01i

La Uk Color Collection è una ricca gamma di tessuti in poliestere ignifugo (British Standards) che ti consente di scegliere i cuscini per l'esterno. Questi tessuti sono ideali per giardini, terrazzi, spiagge e piscine.

Composition
100% High tenacity Polyester

Roll length
25 mt ± 5%

Weight
400 g/m² ± 15

Abrasion Resistance
> 200000 Martindale cycles

Width
140 cm ± 2

Light Fastness
(EN ISO 105-B02) 4

Colour
Slight colour differences between one lot and another have to be considered within commercial tolerance

Fastness to Rubbing
(EN ISO 105-X12) Wet: 4 - Dry: 4

Flammability
EN 1021-1:2006
EN 1021-2:2006
BS 5852:2006 (CRIB 5) M1
California
Technical Bulletin 117:2013

FR Fabrics

PERLA INTENSO

by CREVIN



120 - Waterproof & FR

PERLA DELICATO

by CREVIN

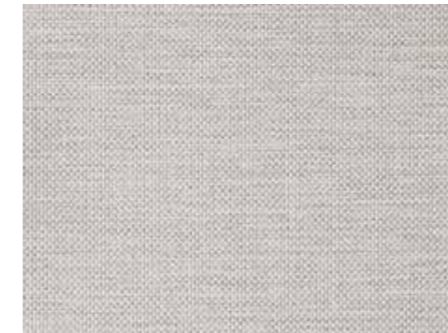

130 - Waterproof & FR

NOCCIOLA

by SUNBRELLA



115 - FR

275 gr/m²

CAMMEO DELICATO

by CREVIN

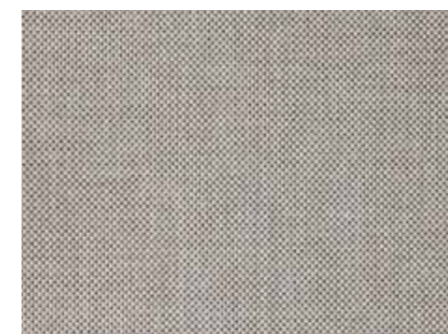

131 - Waterproof & FR

CAMMEO INTENSO

by CREVIN

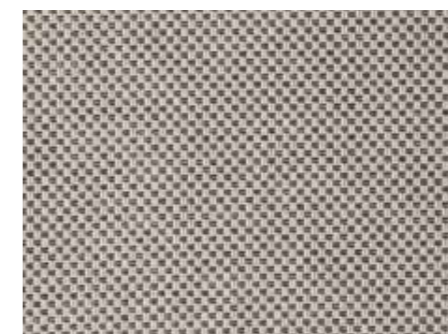

121 - Waterproof & FR

390 gr/m²

ARDESIA DELICATO

by CREVIN

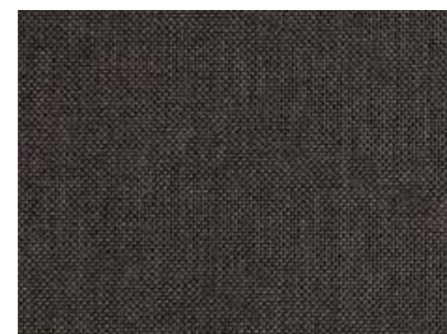

138 - Waterproof & FR

390 gr/m²

Flammability
EN 1021-1:2006
BS 5852 PART1 SOURCE 0
CAL TB 117:2013
NFPA 260 CLASSE 1

Essential Fabrics, Flame Retardant (FR)

MUSCHIO

by SUNBRELLA



154 - Recycled Acrylic & FR

COTTO

by SUNBRELLA



155 - Recycled Acrylic & FR

355 gr/m²

PAPIRO

by SUNBRELLA



156 - Recycled Acrylic & FR

335 gr/m²

Furnishings
Technical
Sheets

Agorà
Amanda
Ariete
Aurora
Capri
Clio
C'est La Vie
Chelsea
Cora
Cosette
Davos
Emy
Experience
Fresbee
Ginger
Igea

Luce
Lulù
Nacre
Olimpia
Panarea
Pertre
Pevero
Salò
Synthesis
Swing
Titanic
Toscana
Treble
Versilia
Welcome
William

Agorà

SITTING AND LOUNGE / SEDUTA E LOUNGE / ASSISE ET LOUNGE / SITZMÖBEL

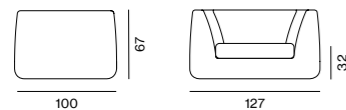

Armchair / Poltrona / Fauteuil / Sessel

AGPOB White / Bianco / Blanc / Weiß
AGPOT Tropical brown
AGCUPO Cushion / Cuscino
 Coussin / Sitzpolster

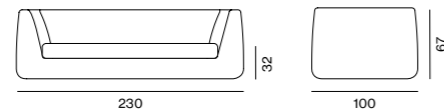

Sofa / Divano / Canapé / Sofa

AGDIB White / Bianco / Blanc / Weiß
AGDIT Tropical brown
AGCUDI Cushion / Cuscino
 Coussin / Sitzpolster

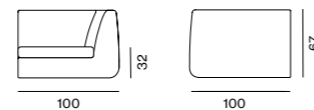

Corner Module / Modulo angolare
 Module angulaire / Eckmodul

AGANB White / Bianco / Blanc / Weiß
AGANT Tropical brown
AGCUAN Cushion / Cuscino
 Coussin / Sitzpolster

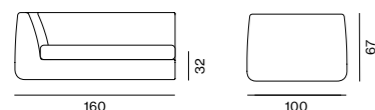

R end module / Modulo finale dx
 Module terminal d / Endmodul rechts

AGMFBD White / Bianco / Blanc / Weiß
AGMFTD Tropical brown
AGCUMF Cushion / Cuscino
 Coussin / Sitzpolster

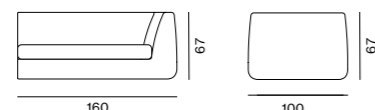

L End module / Modulo finale sx
 Module terminal g / Endmodul links

AGMFBS White / Bianco / Blanc / Weiß
AGMFTS Tropical brown
AGCUMF Cushion / Cuscino
 Coussin / Sitzpolster

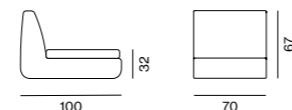

Backrest module / Modulo spalla
 Module dossier / Rückenlehnmodul

AGSPB White / Bianco / Blanc / Weiß
AGSPT Tropical brown
AGCUSP Cushion / Cuscino
 Coussin / Sitzpolster

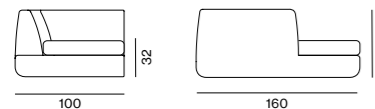

R Lounge module / Modulo lounge dx
 Module lounge d / Lounagemodul rechts

AGMLBD White / Bianco / Blanc / Weiß
AGMLTD Tropical brown
AGCUMLD Cushion / Cuscino
 Coussin / Sitzpolster

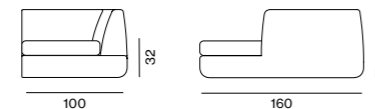

L lounge module / Modulo lounge sx
 Module lounge g / Lounagemodul links

AGMLBS White / Bianco / Blanc / Weiß
AGMLTS Tropical brown
AGCUMLS Cushion / Cuscino
 Coussin / Sitzpolster

SUNLOUNGER / LETTINO / BAIN DE SOLEIL / SONNENLIEGE

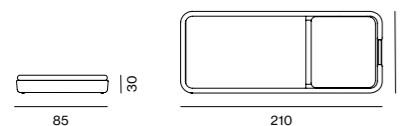

Sunlounger / Lettino / Bain de soleil / Sonnenliege

AGLEB White / Bianco / Blanc / Weiß
AGLET Tropical brown
AECU Cushion / Cuscino
 Coussin / Polsterauflage

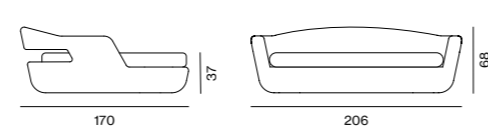

Island / Struttura isola / Îlot / Sonneninsel

EDISTB White / Bianco / Blanc / Weiß
EDIST Tropical brown
EDCUIS Cushion / Cuscino
 Coussin / Sitzpolster

TABLES / TAVOLI / TABLES / TISCHE

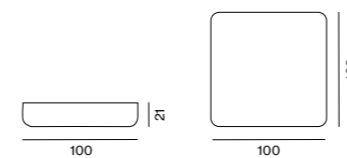

Square coffee table / Tavolo basso quadrato
 Table basse carrée / Quadratischer Couchtisch

BAGTAB White / Bianco / Blanc / Weiß
AGTAB Tropical brown
AGCUPU Cushion pouf / Cuscino pouf
 Coussin pouf / Kissenauflage für Hocker

FINISHES / FINITURE / FINITIONS / AUSFÜHRUNGEN



WaProLace® Synthetic fibre tropical brown
 Fibra sintetica WaProLace® tropical brown
 Fibre synthétique WaProLace® tropical brown
 WaProLace® Synthetikfaser tropical brown



Synthetic fibre white
 Fibra sintetica bianca
 Fibre synthétique blanche
 Synthetikfaser weiß

→ Aluminum / Alluminio / Aluminium / Aluminium

→ WaProLace® synthetic fibre / Fibra sintetica WaProLace® / Fibre synthétique WaProLace® / WaProLace® Synthetikfaser

Amanda

HAMMOCK / AMACA / HAMAC / HÄNGEMATTE

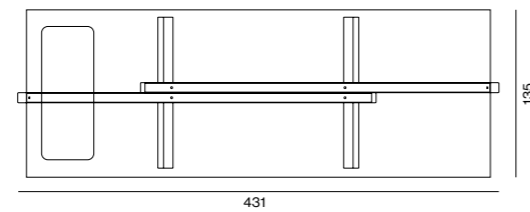
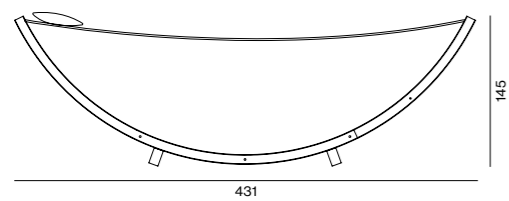

Wooden hammock / Amaca in legno / Hamac en bois / Hängematte mit Holzgestell

- AMACA** 100% cotton off white / Cotone bianco naturale
Coton blanc 100% naturel / 100% Baumwolle naturfarben
- AMACAGM** Polypropylene grey mélange / Polipropilene grigio mélange
Polypropylène gris chiné / Polypropylen graumeliert

COMPLEMENTS / COMPLEMENTI / COMPLÉMENTS / ZUBEHÖR

Net 100% cotton off-white	Rete in corda di cotone bianco grezzo	Filet en corde de coton blanc écru	Netz aus Baumwolle naturfarben	RETE
Net in grey mélange polypropilene	Rete in corda in polipropilene grigio mélange	Filet de corde en polypropylène gris chiné	Netz aus Polypropylen graumeliert	RETEGM
Cushion in quarzo fumé	Cuscino in quarzo fumé	Coussin quartz fumé	Kissen aus Stoff "quarzo fumé"	AMACACUSA002

FINISHES / FINITURE / FINITIONS / AUSFÜHRUNGEN

100% cotton off white
Cotone bianco naturale
Coton blanc 100% naturel
100% Baumwolle naturfarben

Polypropylene grey mélange
Polipropilene grigio mélange
Polypropylène gris chiné
Polypropylen grau meliert

Treated lamellar wood walnut
Legno lamellare impregnato tinto noce
Bois lamellé imprégné couleur noyer
Behandeltes Schichtholz nussfarben

- Treated lamellar wood / Legno lamellare impregnato / Bois lamellaire recourbé / Behandeltes Schichtholz
- 100% cotton / Cotone grezzo / coton blanc / 100% Baumwolle
- Polypropylene / Polipropilene / Polypropylène / Polypropylen

Ariete

LOUNGE / LOUNGE / LOUNGE / LOUNGE

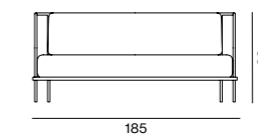
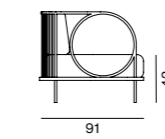
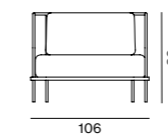
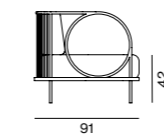

- ARIPOLGBR** Armchair / Poltrona / Fauteuil / Sessel
CUARIPOL Cushion / Cuscino
Coussin / Polster

- ARIDIVGBR** Sofa / Divano / Canapé / Sofa
CUARIDIV Cushion / Cuscino
Coussin / Polster

TABLES / TAVOLI / TABLES / TISCHE

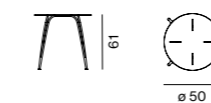

- ARITBROT** Round coffee table / Tavolo basso rotondo
Table basse ronde / Runder Couchtisch

FINISHES / FINITURE / FINITIONS / AUSFÜHRUNGEN

Powder coated galvanized iron bronze
Ferro zincato verniciato a polveri bronzo
Fer galvanisé enduit de poudre bronze
Verzinktes, pulverbeschichtetes Eisen bronze

- Powder coated galvanized iron / Ferro zincato verniciato a polveri / Fer galvanisé enduit de poudre / Verzinktes, pulverbeschichtetes Eisen

Aurora

SITTING / SEDUTE / ASSISES / SITZMÖBEL

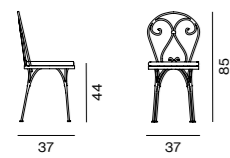

AUSN Chair / Sedia / Chaise / Stuhl
CUABA Cushion / Cuscino / Coussin / Kissen

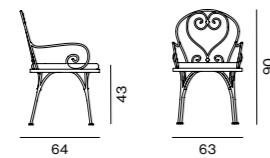

AUPOLG Small armchair / Poltroncina
Petit fauteuil / Armstuhl
CUPAUBA-S2 Cushion / Cuscino / Coussin / Kissen

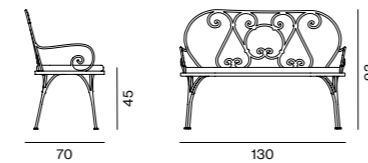

AUDIG Bench / Panchetta / Banc / Bank
CUDAUBA-S2 Cushion / Cuscino / Coussin / Kissen

LOUNGE / LOUNGE / LOUNGE / LOUNGE

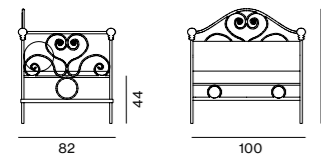

MORPOS Armchair / Poltrona / Fauteuil / Sessel
CUSMOPOA Cushion / Cuscino / Coussin / Polster

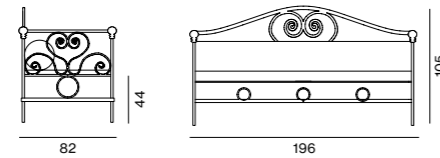

MORDIS Sofa / Divano / Canapé / Sofa
CUSMORA Cushion / Cuscino / Coussin / Polster

SUNLOUNGER / LETTINO / BAIN DE SOLEIL / SONNENLIEGE

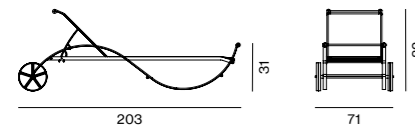

LELEGTM Sunlounger / Lettino / Bain de soleil / Sonnenliege

TABLES / TAVOLI / TABLES / TISCHE

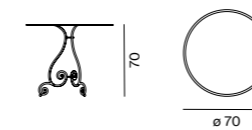

TALFG Round table / Tavolo rotondo
Table ronde / Runder Tisch

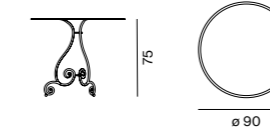

TALFG9 Round table / Tavolo rotondo
Table ronde / Runder Tisch

ACCESSORIES / ACCESSORI / ACCESSOIRES / ZUBEHÖR

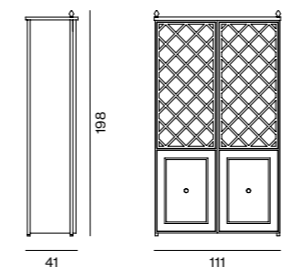

LARM Cupboard / Armadio / Armoire / Schrank

FINISHES / FINITURE / FINITIONS / AUSFÜHRUNGEN

● Powder coated galvanized iron graphite
Ferro zincato verniciato a polveri grafite
Fer galvanisé enduit de poudre graphite
Verzinktes, pulverbeschichtetes Eisen grafitgrau

● Polycarbonate panels (LARM)
Pannelli policarbonato (LARM)
Polycarbonate panneaux (LARM)
Panneele aus Polycarbonat (LARM)

● Technical fabric brown
Tessuto tecnico brown
Tissu technique brown
Technisches Gewebe braun

→ Powder coated galvanized iron / Ferro zincato verniciato a polveri / Fer galvanisé enduit de poudre / Verzinktes, pulverbeschichtetes Eisen
→ Technical fabric / Tessuto tecnico / Tissu technique / technisches Gewebe

→ Powder coated galvanized iron / Ferro zincato verniciato a polveri / Fer galvanisé enduit de poudre / Verzinktes, pulverbeschichtetes Eisen
→ Technical fabric / Tessuto tecnico / Tissu technique / technisches Gewebe

Capri

SITTING / SEDUTE / ASSISES / SITZMÖBEL

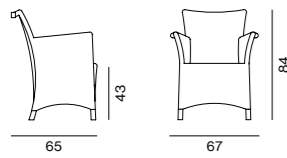

Small armchair / Poltroncina / Petit fauteuil / Armstuhl

CPPOBLW Blue / Blu / Bleu / Blau
CPPOCEW Sky blue / Azzurro / Bleu clair / Hellblau
CPPOGIW Yellow / Giallo / Jaune / Gelb
CPPOPRW Burgundy / Prugna / Prune / Pflaumenblau
CPPOROW Red / Rosso / Rouge / Rot
CPPOVEW Green / Verde / Vert / Grün

CPCUPO Cushion / Cuscino / Coussin / Kissen

FINISHES / FINITURE / FINITIONS / AUSFÜHRUNGEN



WaProLace® blue
 WaProLace® blu
 WaProLace® bleu
 WaProLace® blau



WaProLace® sky blue
 WaProLace® azzurro
 WaProLace® bleu clair
 WaProLace® hellblau



WaProLace® yellow
 WaProLace® giallo
 WaProLace® jaune
 WaProLace® gelb



WaProLace® burgundy
 WaProLace® prugna
 WaProLace® prune
 WaProLace® pflaumenblau



WaProLace® red
 WaProLace® rosso
 WaProLace® rouge
 WaProLace® rot



WaProLace® green
 WaProLace® verde
 WaProLace® vert
 WaProLace® grün

↪ Aluminum / Alluminio / Aluminium / Aluminium
 ↪ WaProLace® synthetic fibre / Fibra sintetica WaProLace® / Fibre synthétique WaProLace® / WaProLace® Synthetikfaser

Clio

SITTING / SEDUTE / ASSISES / SITZMÖBEL

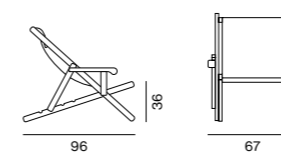

CLI Deckchair with sling in 100% cotton
 Sdraio con telo di cotone 100%
 Transat avec toile 100% coton
 Liegestuhl mit Tuchbespannung aus Baumwolle

CLIOTEL Spare sling / Telo di ricambio
 Toile de rechange / Ersatzbespannung

FINISHES / FINITURE / FINITIONS / AUSFÜHRUNGEN



Teak
 Teak
 Teck
 Teakholz



Cotton off white
 Cotone bianco
 Coton blanc
 Baumwolle naturfarben

↪ Teak / Teak / Teck / Teakholz
 ↪ Cotton off white / Cotone bianco / Coton blanc / Baumwolle naturfarben

C'est La Vie

LOUNGE / LOUNGE / LOUNGE / LOUNGE

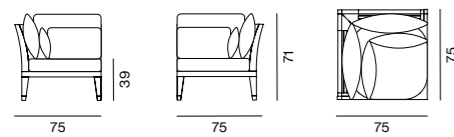

Corner Module / Modulo angolare / Module angulaire / Eckmodul

BOMOAN Structure / Struttura / Structure / Gestell
CUBOMOAN Cushion / Cuscino / Coussin / Polster

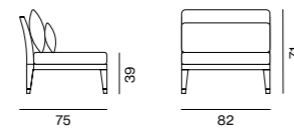

Backrest module / Modulo spalla / Module dossier / Rückenlehnmodul

BOMOSP Structure / Struttura / Structure / Gestell
CUBOMOSP Cushion / Cuscino / Coussin / Polster

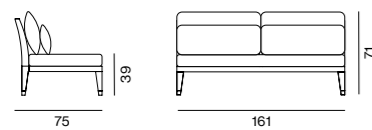

Sofa 2 seats / Divano 2 posti / Canapé 2 places / Zweisitzer Sofa

BOMODI2P Structure / Struttura / Structure / Gestell
CUBOMOSP Cushion / Cuscino / Coussin / Polster

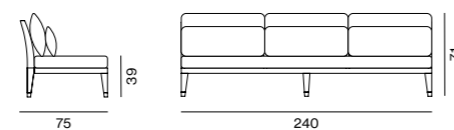

Sofa 3 seats / Divano 3 posti / Canapé 3 places / Dreisitzer Sofa

BOMODI3P Structure / Struttura / Structure / Gestell
CUBOMOSP Cushion / Cuscino / Polster

SUNLOUNGERS / LETTINI / BAINS DE SOLEIL / SONNENLIEGEN

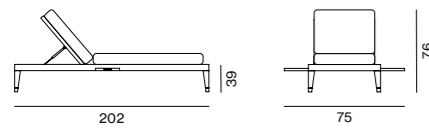

Sunlounger / Lettino / Bain de soleil / Sonnenliege

BOMOLES Structure / Struttura / Structure / Gestell
CUBOMOLES Cushion / Cuscino / Coussin / Polsterauflage

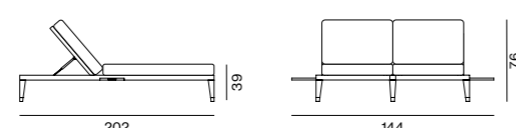

Double sunlounger / Lettino doppio / Bain de soleil double / doppelte Sonnenliege

BOMOLED Structure / Struttura / Structure / Gestell
CUBOMOLES Cushion / Cuscino / Coussin / Polsterauflage

TABLES / TAVOLI / TABLES / TISCHE

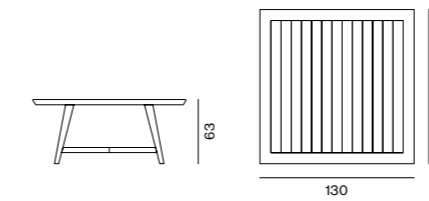

BOMOTAVQ Square table / Tavolo quadrato
 Table carrée / quadratischer Tisch

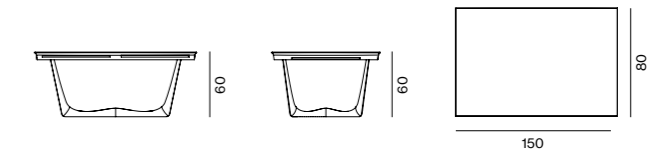

BOMOTF Rectangular table extractable tabletops
 Tavolo rettangolare piani estraibili
 Table rectangulaire avec étagères amovibles
 Rechteckiger Tisch mit ausziehbaren Tischplatten

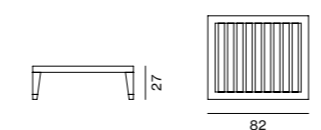

BOMOTB Rectangular coffee table
 Tavolo basso rettangolare
 Table basse rectangulaire
 Rechteckiger Couchtisch

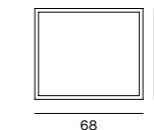

BOMOVA Tray / Vassoio / Plateau / Tablett

CUBOMOTB Cushion pouf / Cuscino pouf
 Coussin pouf / Polster für Couchtisch

FINISHES / FINITURE / FINITIONS / AUSFÜHRUNGEN

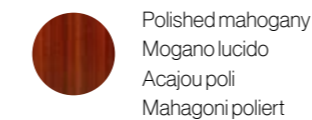

Chelsea

SITTING / SEDUTE / ASSISES / SITZMÖBEL

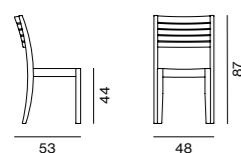

SEBRI Chair / Sedia / Chaise / Stuhl
CUSBRIA Cushion / Cuscino / Coussin / Kissen

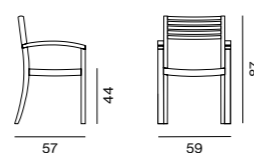

BRISE Small armchair / Poltroncina / Petit fauteuil / Armstuhl
CUSBRIA Cushion / Cuscino / Coussin / Kissen

SUNLOUNGER / LETTINO / BAIN DE SOLEIL / SONNENLIEGE

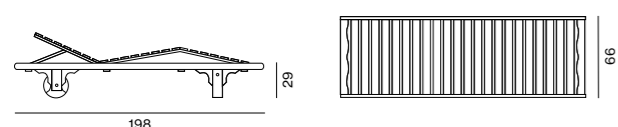

HENLETT Sunlounger / Lettino / Bain de soleil / Sonnenliege
CUHE Cushion / Cuscino / Coussin / Polsterauflage

LOUNGE / LOUNGE / LOUNGE / LOUNGE

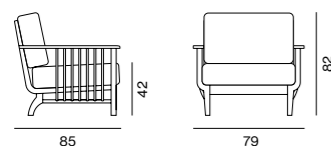

CHPO Armchair / Poltrona / Fauteuil / Sessel
CHCU Set of cushions / Set di cuscini
 Set de coussins / Polsterset

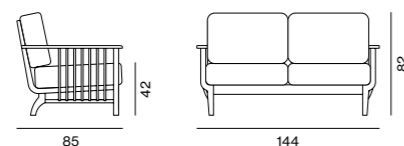

CHDIP 2-seater Sofa / Divano due posti
 Canapé 2 places / Zweisitzer Sofa
CHCU Set of cushions / Set di cuscini
 Set de coussins / Polsterset

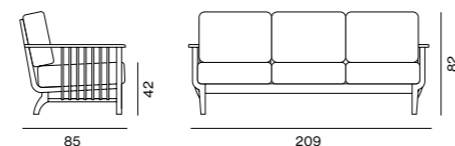

CHDIG 3-seater Sofa / Divano 3 posti
 Canapé 3 places / Dreisitzer Sofa
CHCU Set of cushions / Set di cuscini
 Set de coussins / Polsterset

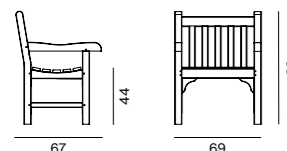

GRPOL Armchair / Poltrona / Fauteuil / Sessel
CUSPLOLGRA Cushion / Cuscino / Coussin / Kissen

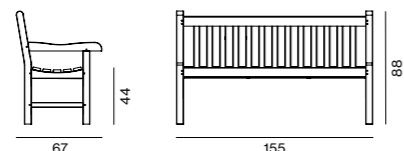

GRDIV15 2-seater Sofa / Divano due posti
 Canapé 2 places / Zweisitzer Sofa
CUDIV15A Set of 2 cushions / Set di 2 cuscini
 Set de 2 coussins / Set mit 2 Kissen

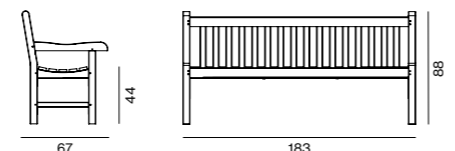

GRDIV18 3-seater Sofa / Divano 3 posti
 Canapé 3 places / Dreisitzer Sofa
CUDIV18A Set of 3 cushions / Set di 3 cuscini
 Set de 3 coussins / Set mit 3 Kissen

→ Teak / Teak / Teck / Teakholz

TABLES / TAVOLI / TABLES / TISCHE

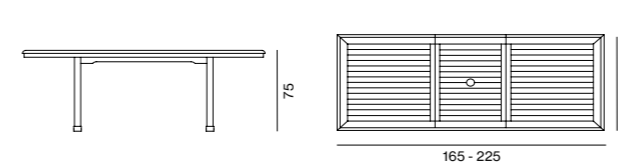

TAMIREP Table extendable / Tavolo allungabile
 Table allongeable / Ausziehbarer Tisch

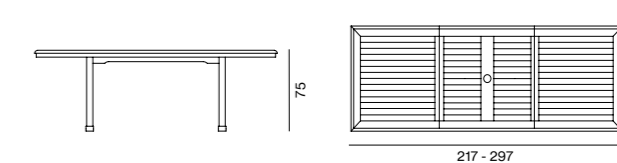

TAMILRE Table extendable / Tavolo allungabile
 Table allongeable / Ausziehbarer Tisch

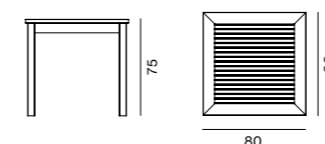

LOTAVQ Square table / Tavolo quadrato
 Table carrée / Quadratischer Tisch

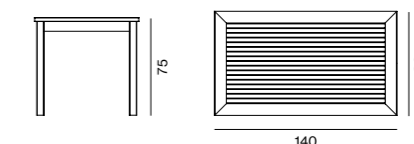

LOTAVR Rectangular table / Tavolo rettangolare
 Table rectangulaire / Rechteckiger Tisch

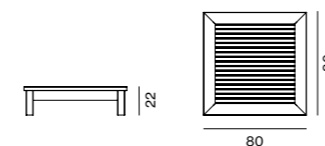

CHETAQ Square coffee table / Tavolo basso quadrato
 Table basse carrée / Quadratischer Couchtisch

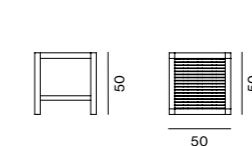

MOTAQB Square coffee table / Tavolo basso quadrato
 Table basse carrée / Quadratischer Couchtisch

CHEST / BAULE / COFFRE / TRUHE

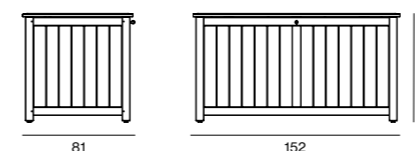

Chest / Baule / Coffre / Truhe

BAUTWAT Assembly kit / In kit di montaggio
 En kit de montage / Im Bausatz
BAUTWAM Assembled / Assemblato
 Assemblé / Fertig montiert

→ Teak / Teak / Teck / Teakholz

FINISHES / FINITURE / FINITIONS / AUSFÜHRUNGEN

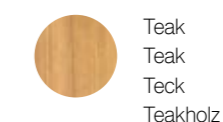

Teak
 Teak
 Teck
 Teakholz

Cora

SITTING / SEDUTE / ASSISES / SITZMÖBEL

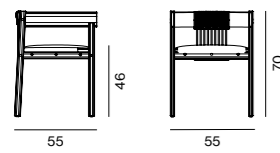

CORSED Chair in teak and rope with seat cushion
Sedia in teak e corda con cuscino di seduta
Chaise en teck et corde avec coussin d'assise
Stuhl aus Teakholz und Seil mit Sitzkissen

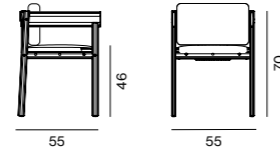

CORSEDC Chair in teak and rope with seat cushion and backrest
Sedia in teak e corda con cuscino di seduta e schienale
Chaise en teck et corde avec coussin d'assise et de dossier
Stuhl aus Teakholz und Seil mit Sitz- und Rückenpolster

LOUNGE / LOUNGE / LOUNGE / LOUNGE

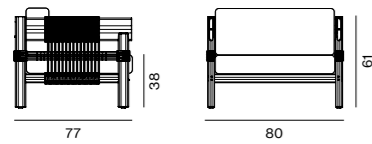

CORPOL Armchair in teak and rope with seat cushion and backrest
Poltrona in teak e corda con cuscino di seduta e schienale
Fauteuil en teck et corde avec coussin d'assise et de dossier
Sessel aus Teakholz und Seil mit Sitz- und Rückenpolster

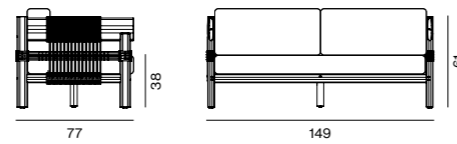

CORDIV2P 2-seater sofa in teak and rope with seat cushion and backrest
Divano due posti in teak e corda con cuscino di seduta e schienale
Canapé deux places en teck et corde avec coussins d'assise et de dossier
Zweisitzer aus Teakholz und Seil mit Sitz- und Rückenpolstern

SUNLOUNGERS / LETTINI / BAINS DE SOLEIL / SONNENLIEGEN

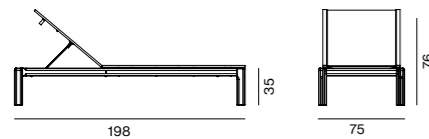

CORLET Sun lounger in teak with sand textile
Lettino in teak e textilene sabbia
Chaise longue en teck et textilène sable
Liege aus Teakholz und sandfarbenem Textilene

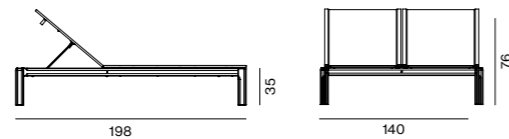

CORLEDOT Double sun lounger in teak with sand textile
Lettino doppio in teak e textilene sabbia
Double chaise longue en teck et textilène sable
Doppelliege aus Teakholz und sandfarbenem Textilene

CORCULET Cushion / Cuscino / Coussin / Polsterauflage

CORCUDOLET Cushion / Cuscino / Coussin / Polsterauflage

- Teak / Teak / Teck / Teakholz
- Fiberstone / Fiberstone / Fiberstone / Fiberstone
- Polypropylene cord / Corda polipropilene / Corde en polypropylène / Polypropylen-Seil

ISLAND / ISOLA / ÎLOT / SONNENINSEL

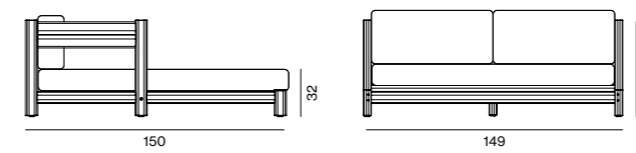

CORBED Island in teak and rope
Isola in teak e corda
Îlot en teck et corde
Sonneninsel aus Teakholz und Seil

TABLES / TAVOLI / TABLES / TISCHE

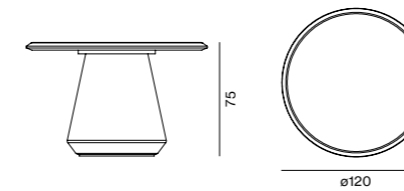

CORTAV120 Round fiberstone table
Tavolo rotondo in fiberstone
Table ronde en fiberstone
Runder Tisch aus Fiberstone

FINISHES / FINITURE / FINITIONS / AUSFÜHRUNGEN

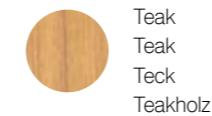

Teak
Teak
Teck
Teakholz



Polipropylene cord ecru
Corda polipropilene ecru
Corde polypropylène écru
Polypropylen-Seil Farbe ecru



Fiberstone
Fiberstone
Fiberstone
Fiberstone

- Teak / Teak / Teck / Teakholz
- Fiberstone / Fiberstone / Fiberstone / Fiberstone
- Polypropylene cord / Corda polipropilene / Corde en polypropylène / Polypropylen-Seil

Cosette

SITTING / SEDUTE / ASSISES / SITZMÖBEL

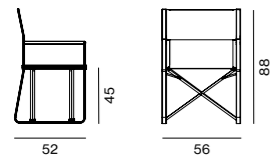

Small armchair in aluminium / Poltroncina in alluminio
 Petit fauteuil en aluminium / Armstuhl aus Aluminium

OCPOLB White structure / Struttura in bianco
 Structure en Blanc / Weißes Gestell

OCPOLG Graphite structure / Struttura in Grafite
 Structure en Graphite / Grafitgraues Gestell

OCTELB Cover hemp white / Telo bianco canapa
 Toile blanc chanvre / Bespannung naturweiß

OCTELBR Cover brown / Telo brown
 Toile marron / Bespannung braun

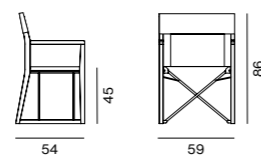

Small armchair in teak / Poltroncina in teak
 Petit fauteuil en teck / Armstuhl aus Teakholz

COPOL Structure / Struttura / Structure / Gestell

COPOLT Cover dove grey / Telo tortora
 Toile tourterelle / Bespannung taubengrau

COPOLB Cover hemp white / Telo bianco canapa
 Toile blanc chanvre / Bespannung naturweiß

COPOLM Cover brown / Telo brown
 Toile marron / Bespannung braun

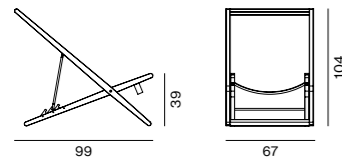

Deckchair / Sdraio in teak / Transat en teck / Liegestuhl aus Teakholz

SDCOST Structure / Struttura / Structure / Gestell

TELCOSTO Dove grey polypropylene fabric / Tessuto polipropilene tortora
 Tissu polypropylène taupe / Taubengrauer Stoff aus Polypropylen

TELCOSBC Sling hemp white / Telo bianco canapa
 Toile blanc chanvre / Bespannung naturweiß

TELCOSBM Sling brown / Telo brown
 Toile marron / Bespannung braun

TABLE / TAVOLO / TABLE / TISCH

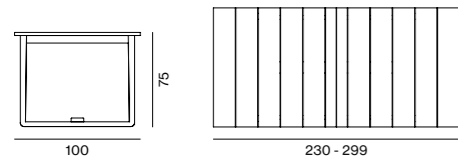

COTARE Rectangular table / Tavolo rettangolare / Table rectangulaire / Rechteckiger Tisch

FINISHES / FINITURE / FINITIONS / AUSFÜHRUNGEN



Teak
 Teak
 Teck
 Teakholz



Aluminum graphite
 Alluminio grafite
 Aluminium graphite
 Aluminium grafitgrau

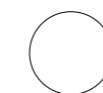

Aluminum white
 Alluminio bianco
 Aluminium blanc
 Aluminium weiß



Brown technical fabric
 Tessuto tecnico brown
 Tissu technique en marron
 Technisches Gewebe braun



Hemp white technical fabric
 Tessuto tecnico bianco canapa
 Tissu technique blanc chanvre
 Technisches Gewebe naturweiß



Dove grey polypropylene fabric
 Tessuto polipropilene tortora
 Tissu polypropylène taupe
 Taubengrauer Stoff aus Polypropylen

- ↪ Teak / Teak / Teck / Teakholz
- ↪ Aluminum / Alluminio / Aluminium / Aluminium
- ↪ Technical fabric / Tessuto tecnico / Tissu technique / technisches Gewebe
- ↪ Polypropylene fabric / Tessuto polipropilene / Tissu polypropylène / Polypropylen Stoff

- ↪ Teak / Teak / Teck / Teakholz
- ↪ Aluminum / Alluminio / Aluminium / Aluminium
- ↪ Technical fabric / Tessuto tecnico / Tissu technique / technisches Gewebe
- ↪ Polypropylene fabric / Tessuto polipropilene / Tissu polypropylène / Polypropylen Stoff

Davos

SITTING AND LOUNGE / SEDUTA E LOUNGE / ASSISES ET LOUNGE / LOUNGEMÖBEL

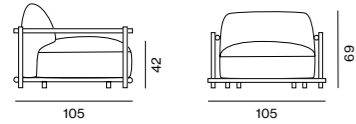

Armchair / Poltrona / Fauteuil / Sessel

NUPOLG Fabric upholstery / Cuscineria in tessuto
Coussins en tissu / Polster mit Stoffbezug

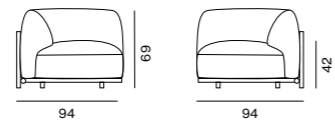

Corner Module / Modulo angolare
Module angulaire / Eckmodul

NUANGOLG Fabric upholstery / Cuscineria in tessuto
Coussins en tissu / Polster mit Stoffbezug

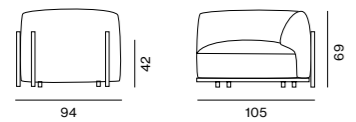

L End module / Modulo finale sx
Module terminal g / Endmodul links

NUFINGS Fabric upholstery / Cuscineria in tessuto
Coussins en tissu / Polster mit Stoffbezug

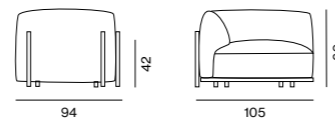

R end module / Modulo finale dx
Module terminal d / Endmodul rechts

NUFINGD Fabric upholstery / Cuscineria in tessuto
Coussins en tissu / Polster mit Stoffbezug

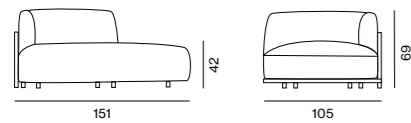

L lounge module / Modulo lounge sx
Module lounge g / Loungemodul links

NULOUGS Fabric upholstery / Cuscineria in tessuto
Coussins en tissu / Polster mit Stoffbezug

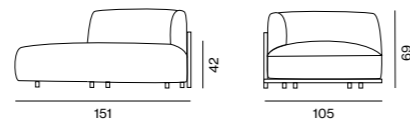

R Lounge module / Modulo lounge dx
Module lounge d / Loungemodul rechts

NULOUGD Fabric upholstery / Cuscineria in tessuto
Coussins en tissu / Polster mit Stoffbezug

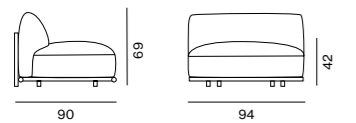

Backrest module / Modulo spalla
Module dossier / Rückenlehnmodul

NUSPAG Fabric upholstery / Cuscineria in tessuto
Coussins en tissu / Polster mit Stoffbezug

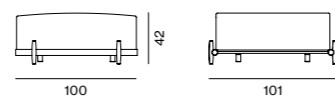

Pouf with seat cushion / Pouf con cuscino di seduta
Pouf avec coussin de assise / Hocker mit Sitzpolster

NUPUFGC Fabric upholstery / Cuscineria in tessuto
Coussins en tissu / Polster mit Stoffbezug

→ Aluminum / Alluminio / Aluminium / Aluminium
→ Porcelain stone ware / Gres porcellanato / Grès cérame / Feinsteinzeug

SUNLOUNGER / LETTINO / BAIN DE SOLEIL / SONNENLIEGE

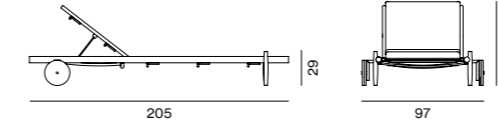

NULETG Sunlounger / Lettino / Bain de soleil / Sonnenliege
NUCULET Cushion / Cuscino / Coussin / Polsterauflage

TABLES / TAVOLI / TABLES / TISCHE

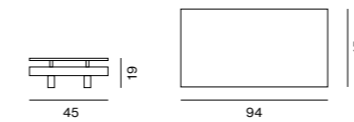

Rectangular coffee table module top porcelain stoneware
Modulo tavolo basso rettangolare piano gres porcellanato
Module table basse rectangulaire avec plateau grès cérame
Rechteckiges Couchtisch-Modul Tischplatte Feinsteinzeug

NUTACEG Pietra

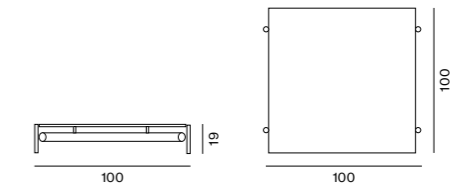

Square coffee table top porcelain stoneware
Tavolo basso quadrato piano gres porcellanato
Table basse carrée avec plateau grès cérame
Quadratischer Couchtisch Tischplatte Feinsteinzeug

NUTABG Pietra

FINISHES / FINITURE / FINITIONS / AUSFÜHRUNGEN

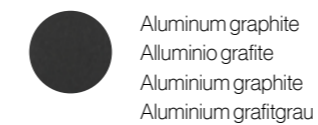

Aluminum graphite
Alluminio grafite
Aluminium graphite
Aluminium grafitgrau



Porcelain stoneware Pietra
Gres porcellanato Pietra
Grès cérame Pietra
Feinsteinzeug Pietra



Sand fabric Batyline Serge Ferrari
Telo Batyline Serge Ferrari sabbia
Tissu sable en Batyline Serge Ferrari
Sandfarbene Bespannung in Batyline Serge Ferrari

→ Aluminum / Alluminio / Aluminium / Aluminium
→ Porcelain stone ware / Gres porcellanato / Grès cérame / Feinsteinzeug

Emy

SITTING / SEDUTE / ASSISES / SITZMÖBEL

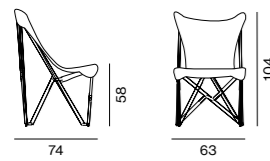

Small armchair / Poltroncina / Petit fauteuil / Armstuhl

EMY Structure / Struttura / Structure / Gestell
EMYTEL Sling in 100% cotton / Telo di cotone 100% / Toile 100% coton / Bespannung aus 100% Baumwolle

Experience

SITTING / SEDUTE / ASSISES / SITZMÖBEL

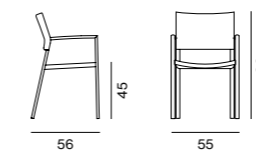

JOSEG Chair / Sedia / Chaise / Stuhl

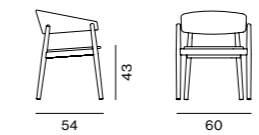

EXLPOGW Small armchair / Poltroncina
Petit fauteuil / Armstuhl

LOUNGE / LOUNGE / LOUNGE / LOUNGE

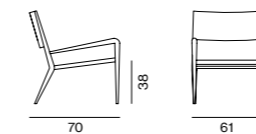

EXLPO Armchair / Poltrona
Fauteuil / Sessel

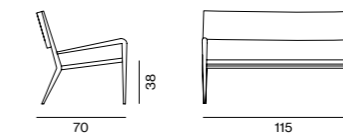

EXLDIV Sofa / Divano / Canapé / Sofa

SUNLOUNGER / LETTINO / BAIN DE SOLEIL / SONNENLIEGE

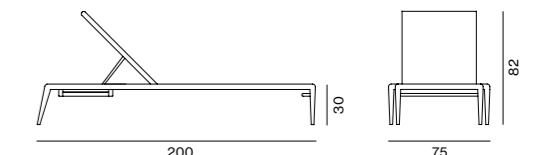

EXLET Sunlounger / Lettino
Bain de soleil / Sonnenliege
CUEXLETC01 Cushion / Cuscino
Coussin / Polsterauflage

TABLES / TAVOLI / TABLES / TISCHE

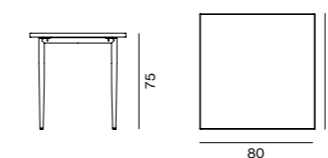

EXLTAQU80FL Square table top porcelain stoneware
Tavolo quadrato piano gres porcellanato
Table carrée avec plateau grès cérame
Quadratischer Tisch mit Tischplatte
aus Feinsteinzeug

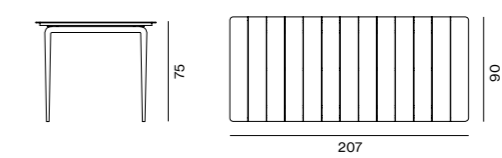

EXLTAVA Rectangular table
Tavolo rettangolare
Table rectangulaire
Rechteckiger Tisch

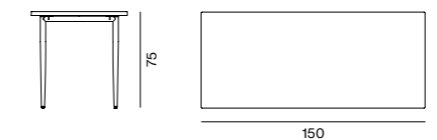

EXLTARE150FL Rectangular table top porcelain stoneware
Tavolo rettangolare con piano gres porcellanato
Table rectangulaire avec plateau grès cérame
Rechteckiger Tisch mit Tischplatte aus Feinsteinzeug

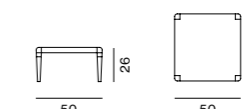

EXTALQ Square coffee table
Tavolo basso quadrato
Table basse carrée
Quadratischer Couchtisch

FINISHES / FINITURE / FINITIONS / AUSFÜHRUNGEN



Teak
Teak
Teck
Teakholz



Cotton off white
Cotone bianco
Coton blanc
Baumwolle naturfarben

→ Teak / Teak / Teck / Teakholz
 → Cotton off white / Cotone bianco grezzo / Coton blanc / Baumwolle naturfarben

FINISHES / FINITURE / FINITIONS / AUSFÜHRUNGEN



WaProLace® antique brown



Porcelain stoneware Deserto
Gres porcellanato Deserto
Grès cérame Deserto
Feinsteinzeug Deserto



Aluminum graphite
Alluminio grafite
Aluminium graphite
Aluminium grafitgrau

→ Aluminum / Alluminio / Aluminium / Aluminium
 → WaProLace® synthetic fibre / Fibra sintetica WaProLace® / Fibre synthétique WaProLace® / WaProLace® Synthetikfaser
 → Porcelain stone ware / Gres porcellanato / Grès cérame / Feinsteinzeug

Fresbee

TABLES / TAVOLI / TABLES / TISCHE

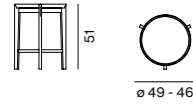

Round coffee table / Tavolo basso rotondo
Table basse ronde / Runder Beistelltisch

FRIPINAL	Aluminum structure - aluminum tray Struttura in alluminio - vassoio in alluminio Structure en aluminium - plateau en aluminium Gestell aus Aluminium - Tablett aus Aluminium
FRIPINT	Teak structure - aluminum tray Struttura in teak - vassoio in alluminio Structure en teck - plateau en aluminium Gestell aus Teakholz - Tablett aus Aluminium

FINISHES / FINITURE / FINITIONS / AUSFÜHRUNGEN

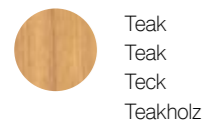

Teak
Teak
Teck
Teakholz



Aluminum graphite
Alluminio grafite
Aluminium graphite
Aluminium grafitgrau

→ Teak / Teak / Teck / Teakholz
→ Aluminum / Alluminio/ Aluminium / Aluminium

Ginger

SITTING / SEDUTE / ASSISES / SITZMÖBEL

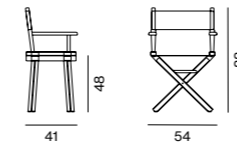

Small armchair / Poltroncina / Petit fauteuil / Armstuhl

GINPOST	Structure / Struttura / Structure / Gestell
GINTEL	Cover and cushion in 100% cotton Teli e cuscino di cotone 100% Toiles et coussin 100% coton Bespannung und Sitzkissen aus 100% Baumwolle
GITECAN	Cover Batyline Serge Ferrari beige Telo Batyline Serge Ferrari beige Toile en Batyline Serge Ferrari beige Bespannung aus Batyline Serge Ferrari Farbe beige
GINTEXBI	Cover quilted plastic fabric white Telo di tessuto plastico trapuntato bianco Toiles en tissu plastique matelassé blanc Bespannung aus aus gestepptem, weißem Kunststoff
GINTBAVO	Cover Batyline Serge Ferrari green Telo Batyline Serge Ferrari verde Toile en Batyline Serge Ferrari vert Bespannung aus Batyline Serge Ferrari Farbe grün

FINISHES / FINITURE / FINITIONS / AUSFÜHRUNGEN



Teak
Teak
Teck
Teakholz



Cotton off white (GINTEL)
Cotone bianco (GINTEL)
Coton blanc (GINTEL)
Baumwolle naturfarben (GINTEL)



Cover and cushion Masterline Colour Collection pg. 302
Teli e cuscino Masterline Colour Collection pg. 302
Toiles et coussin Masterline Colour Collection pg. 302
Bespannung und Sitzkissen Masterline Colour Collection Seite 302



Batyline Serge Ferrari beige (GITECAN)
Batyline Serge Ferrari beige (GITECAN)
Batyline Serge Ferrari beige (GITECAN)
Batyline Serge Ferrari beige (GITECAN)



Batyline Serge Ferrari green (GINTBAVO)
Batyline Serge Ferrari verde (GINTBAVO)
Batyline Serge Ferrari vert (GINTBAVO)
Batyline Serge Ferrari grün (GINTBAVO)



Plastic fabric white (GINTEXBI)
Tessuto plastico trapuntato bianco (GINTEXBI)
Tissu plastique matelassé blanc (GINTEXBI)
Kunststoffgewebe Weiß (GINTEXBI)

→ Teak / Teak / Teck / Teakholz
→ Cotton off white / Cotone bianco grezzo / Coton blanc / Baumwolle naturfarben
→ Batyline Serge Ferrari / Batyline Serge Ferrari / Batyline Serge Ferrari / Batyline Serge Ferrari
→ Plastic fabric / Tessuto plastico / Tissu plastique / Kunststoffgewebe

SITTING / SEDUTE / ASSISES / SITZMÖBEL

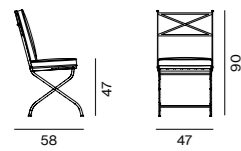

IGSEG Folding chair with seat and back cushions
Sedia pieghevole con cuscini di seduta e schienale
Chaise pliante avec coussins d'assise et de dossier
Klappstuhl mit Sitz- und Rückenpolstern

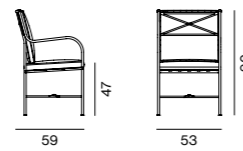

IGSEBRG Armchair with seat and back cushions
Sedia con braccioli con cuscini di seduta e schienale
Chaise avec accoudoirs et coussins d'assise et de dossier
Stuhl mit Armlehnen und Sitz- und Rückenpolstern

LOUNGE / LOUNGE / LOUNGE / LOUNGE

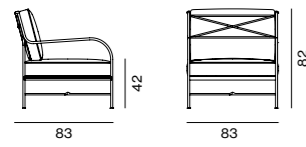

IGPOLG Armchair with seat and back cushions
Poltrona con cuscini di seduta e schienale
Fauteuil avec coussins d'assise et de dossier
Sessel mit Sitz- und Rückenpolstern

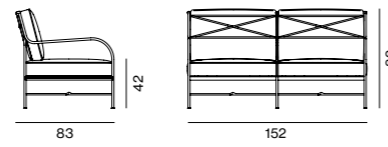

IGDIV2PG 2-seater sofa with seat and back cushions
Divano 2 posti con cuscini di seduta e schienale
Canapé 2 places avec coussins d'assise et de dossier
Zweisitzer-Sofa mit Sitz- und Rückenpolstern

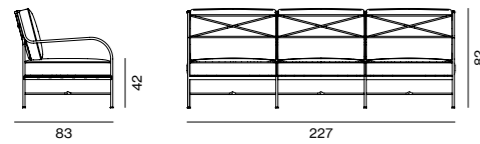

IGDIV3PG 3-seater sofa with seat and back cushions
Divano 3 posti con cuscini di seduta e schienale
Canapé 3 places avec coussins d'assise et de dossier
Dreisitzer-Sofa mit Sitz- und Rückenpolstern

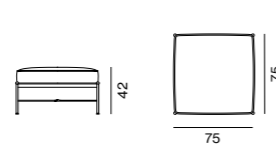

IGPUFG Pouf / Pouf / Pouf / Hocker

SUNLOUNGER / LETTINO / BAIN DE SOLEIL / SONNENLIEGE

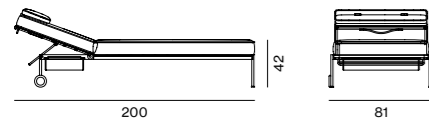

IGLETG Sunlounger / Lettino
Bain de soleil / Sonnenliege
CUIGLET Cushion / Cuscino / Coussin / Polsterauflage

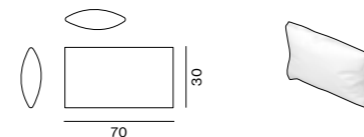

CUIGLOM Cushion / Cuscino
Coussin / Polsterauflage

TABLES / TAVOLI / TABLES / TISCHE

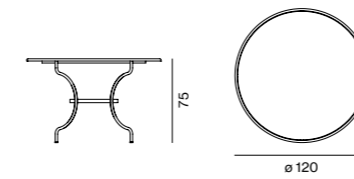

IGTAROG Round table / Tavolo rotondo
Table ronde / Runder Tisch

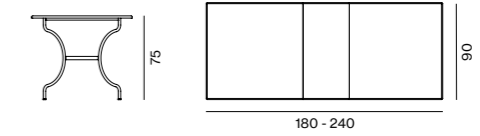

IGTARETG Rectangular extendable table / Tavolo allungabile rettangolare
Table extensible rectangulaire / Rechteckiger Ausziehtisch

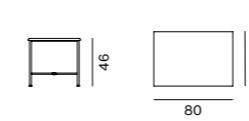

IGTBR8050G Rectangular coffee table
Tavolo basso rettangolare
Table basse rectangulaire
Rechteckiger Couchtisch

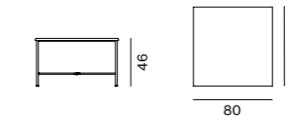

IGTBQG Square coffee table
Tavolo basso quadrato
Table basse carrée
Quadratischer Couchtisch

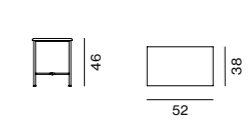

IGTBR5238G Rectangular coffee table
Tavolo basso rettangolare
Table basse rectangulaire
Rechteckiger Couchtisch

ALCOVE / ALCOVA / ALCÔVE / ALKOVEN

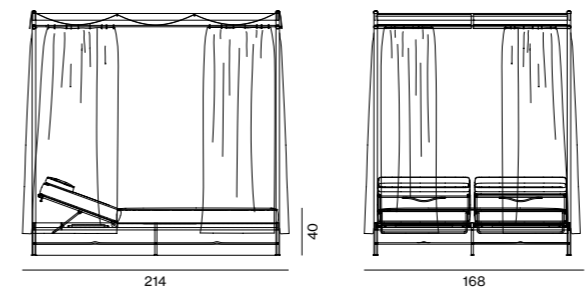

IGALCO Alcove with cushions and curtains
Alcova completa di cuscini e tende
Alcôve complète avec coussins et rideaux
Alkoven komplett mit Kissen und Vorhängen

FINISHES / FINITURE / FINITIONS / AUSFÜHRUNGEN

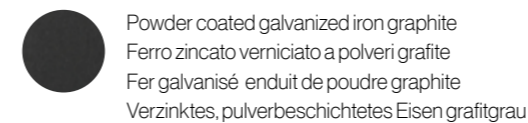

Luce

SITTING AND LOUNGE / SEDUTE E LOUNGE / ASSISES ET LOUNGE / SITZ- UND LOUNGEMÖBEL

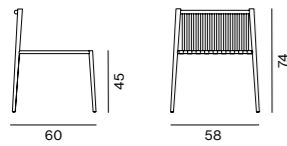

Chair / Sedia / Chaise / Stuhl

LUNSBB White / Bianco / Blanc / Weiß
LUNSBG Graphite / Grafite / Graphite / Grafitgrau

aluminum seat / seduta alluminio / assise en aluminium / Sitzfläche aus Aluminium

LUNALSBB White / Bianco / Blanc / Weiß
LUNALSBG Graphite / Grafite / Graphite / Grafitgrau

LUCUSB Cushion / Cuscino / Coussin / Kissen

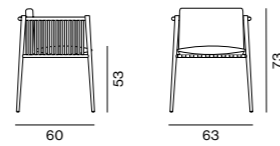

Small armchair / Poltroncina / Petit fauteuil / Armstuhl

LUNSEB White / Bianco / Blanc / Weiß
LUNSEG Graphite / Grafite / Graphite / Grafitgrau

aluminum seat / seduta alluminio / assise en aluminium / Sitzfläche aus Aluminium

LUNALSEB White / Bianco / Blanc / Weiß
LUNALSEG Graphite / Grafite / Graphite / Grafitgrau

LUCUSE Cushion / Cuscino / Coussin / Kissen

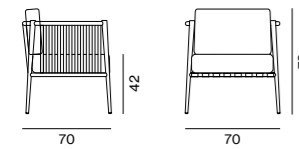

Armchair / Poltrona / Fauteuil / Sessel

LUNPOB White / Bianco / Blanc / Weiß
LUNPOG Graphite / Grafite / Graphite / Grafitgrau

aluminum seat / seduta alluminio / assise en aluminium / Sitzfläche aus Aluminium

LUNALPOB White / Bianco / Blanc / Weiß
LUNALPOG Graphite / Grafite / Graphite / Grafitgrau

LUCUPO Cushion / Cuscino / Coussin / Polster

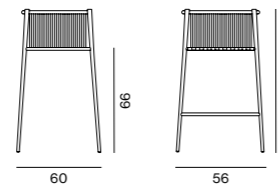

Stool / Sgabello / Tabouret / Barhocker

LUNSGAB White / Bianco / Blanc / Weiß
LUNSGAG Graphite / Grafite / Graphite / Grafitgrau

aluminum seat / seduta alluminio / assise en aluminium / Sitzfläche aus Aluminium

LUNALSGAB White / Bianco / Blanc / Weiß
LUNALSGAG Graphite / Grafite / Graphite / Grafitgrau

LUCUSGA Cushion / Cuscino / Coussin / Kissen

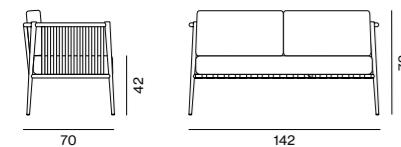

2-seater Sofa / Divano due posti / Canapé 2 places / Zweisitzer Sofa

LUNDIB White / Bianco / Blanc / Weiß
LUNDIG Graphite / Grafite / Graphite / Grafitgrau

aluminum seat / seduta alluminio / assise en aluminium / Sitzfläche aus Aluminium

LUNALDIB White / Bianco / Blanc / Weiß
LUNALDIG Graphite / Grafite / Graphite / Grafitgrau

LUCUDI Cushion / Cuscino / Coussin / Polster

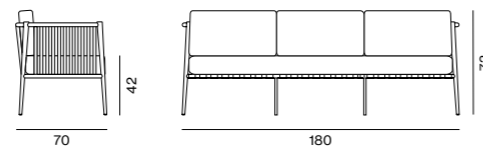

3-seater Sofa / Divano tre posti / Canapé 3 places / Dreisitzer Sofa

LUNDI3PB White / Bianco / Blanc / Weiß
LUNDI3PG Graphite / Grafite / Graphite / Grafitgrau

aluminum seat / seduta alluminio / assise en aluminium / Sitzfläche aus Aluminium

LUNALDI3PB White / Bianco / Blanc / Weiß
LUNALDI3PG Graphite / Grafite / Graphite / Grafitgrau

LUCUDI3P Cushion / Cuscino / Coussin / Polster

→ Aluminum tubular / Tube di alluminio / Tubulaire en aluminium / Aluminiumrohr
 → Polyolefin cord / Corda poliolefinica / Cordon polyoléfine / Polyolefin Seil
 → Porcelain stone ware / Gres porcellanato / Grès cérame / Feinsteinzeug

SITTING AND LOUNGE / SEDUTE E LOUNGE / ASSISES ET LOUNGE / SITZ- UND LOUNGEMÖBEL

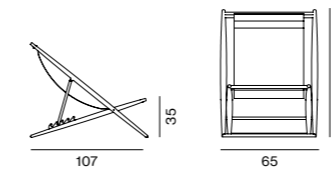

LUSDRB White deckchair with sling ecru
 Sdraio bianca con telo ecru
 Transat blanc avec toile écru
 Elfenbeinfarbener Liegestuhl mit Bespannung ecru

LUSDRG Graphite deckchair with sling antracite
 Sdraio grafite con telo antracite
 Transat graphite avec toile anthracite
 Grafitgrauer Liegestuhl mit Bespannung anthrazitfarben

SUNLOUNGER / LETTINO / BAIN DE SOLEIL / SONNENLIEGE

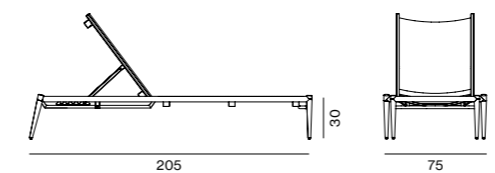

Sunlounger / Lettino / Bain de soleil / Sonnenliege

LUNLETB White / Bianco / Blanc / Weiß
LUNLETG Graphite / Grafite / Graphite / Grafitgrau
LUCULET Cushion / Cuscino / Coussin / Polsterauflage

→ Aluminum tubular / Tube di alluminio / Tubulaire en aluminium / Aluminiumrohr
 → Polyolefin cord / Corda poliolefinica / Cordon polyoléfine / Polyolefin Seil
 → Porcelain stone ware / Gres porcellanato / Grès cérame / Feinsteinzeug

Luce

TABLES / TAVOLI / TABLES / TISCHE

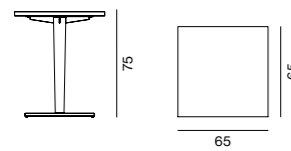

Square table / Tavolo quadrato / Table carrée / Quadratischer Tisch

LUNTAQU65B White / Bianco / Blanc / Weiß
LUNTAQU65G Graphite / Grafite / Graphite / Grafitgrau

with porcelain stoneware top / con piano gres porcellanato
 avec plateau grès cérame / mit Tischplatte aus Feinsteinzeug

LUNTAQU65BFL White / Bianco / Blanc / Weiß
LUNTAQU65GFL Graphite / Grafite / Graphite / Grafitgrau

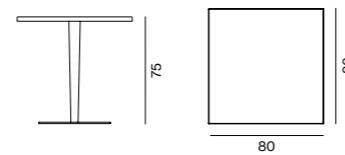

Square table / Tavolo quadrato / Table carrée / Quadratischer Tisch

LUNTAQU80B White / Bianco / Blanc / Weiß
LUNTAQU80G Graphite / Grafite / Graphite / Grafitgrau

with porcelain stoneware top / con piano gres porcellanato
 avec plateau grès cérame / mit Tischplatte aus Feinsteinzeug

LUNTAQU80BFL White / Bianco / Blanc / Weiß
LUNTAQU80GFL Graphite / Grafite / Graphite / Grafitgrau

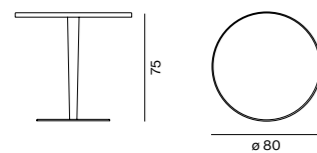

Round table / Tavolo rotondo / Table ronde / Runder Tisch

LUNTARO80B White / Bianco / Blanc / Weiß
LUNTARO80G Graphite / Grafite / Graphite / Grafitgrau

with porcelain stoneware top / con piano gres porcellanato
 avec plateau grès cérame / mit Tischplatte aus Feinsteinzeug

LUNTARO80BFL White / Bianco / Blanc / Weiß
LUNTARO80GFL Graphite / Grafite / Graphite / Grafitgrau

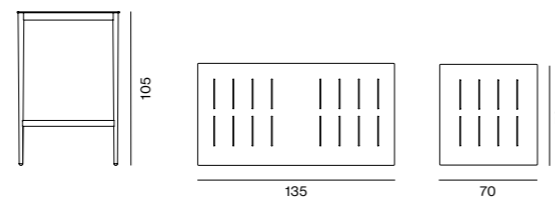

Tall table rectangular / Tavolo alto rettangolare
 Table haute rectangulaire / Rechteckiger Stehtisch

LUNTABAREB White / Bianco / Blanc / Weiß
LUNTABAREG Graphite / Grafite / Graphite / Grafitgrau

Tall square table / Tavolo alto quadrato
 Table haute carrée / Quadratischer Stehtisch

LUNTABAQUB White / Bianco / Blanc / Weiß
LUNTABAQUG Graphite / Grafite / Graphite / Grafitgrau

TABLES / TAVOLI / TABLES / TISCHE

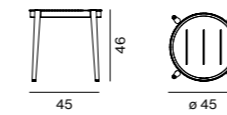

Round table / Tavolo rotondo / Table ronde / Runder Tisch

LUNSTB White / Bianco / Blanc / Weiß
LUNSTG Graphite / Grafite / Graphite / Grafitgrau

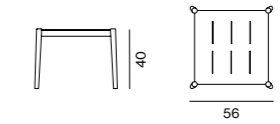

Square coffee table / Tavolo basso quadrato
 Table basse carrée / Quadratischer Couchtisch

LUNTBQB White / Bianco / Blanc / Weiß
LUNTBQG Graphite / Grafite / Graphite / Grafitgrau

with porcelain stoneware top / con piano gres porcellanato
 avec plateau grès cérame / mit Tischplatte aus Feinsteinzeug

LUNTBQBFL White / Bianco / Blanc / Weiß
LUNTBQGFL Graphite / Grafite / Graphite / Grafitgrau

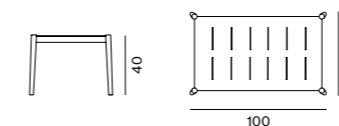

Rectangular coffee table / Tavolo basso rettangolare
 Table basse rectangulaire / Rechteckiger Couchtisch

LUNTBREB White / Bianco / Blanc / Weiß
LUNTBREG Graphite / Grafite / Graphite / Grafitgrau

with porcelain stoneware top / con piano gres porcellanato
 avec plateau grès cérame / mit Tischplatte aus Feinsteinzeug

LUNTBREBFL White / Bianco / Blanc / Weiß
LUNTBREGFL Graphite / Grafite / Graphite / Grafitgrau

FINISHES / FINITURE / FINITIONS / AUSFÜHRUNGEN

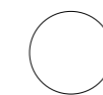

Aluminum tubular white
 Tubolare di alluminio bianco
 Tube en aluminium blanc
 Aluminiumrohr Weiß



Aluminum tubular graphite
 Tubolare di alluminio grafite
 Tube en aluminium graphite
 Aluminiumrohr grafitgrau



Ecrú technical fabric
 Tessuto ecrú
 Tissu technique écrú
 Technisches Gewebe ecrú

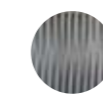

Melange sand polyolefin cord
 Corda poliolefinica sabbia mélange
 Cordon polyoléfine sable chiné
 Polyolefin-Seil Farbe sand - meliert

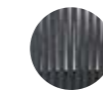

Melange charcoal grey polyolefin cord
 Corda poliolefinica grigio carbone mélange
 Cordon polyoléfine gris anthracite chiné
 Polyolefin-Seil Farbe anthrazitgrau - meliert

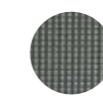

Antracite technical fabric
 Tessuto antracite
 Tissu technique anthracite
 Technisches Gewebe anthrazitfarben



Porcelain stoneware Deserto
 Gres porcellanato Deserto
 Grès cérame Deserto
 Feinsteinzeug Deserto



Textilene beige



Polipropylene cord ecrú
 Corda polipropilene ecrú
 Corde polypropylène écrú
 Polipropylen-Seil Farbe ecrú

→ Aluminum tubular / Tube di alluminio / Tubulaire en aluminium / Aluminiumrohr
 → Polyolefin cord / Corda poliolefinica / Cordon polyoléfine / Polyolefin Seil
 → Porcelain stone ware / Gres porcellanato / Grès cérame / Feinsteinzeug

Lulù

SITTING / SEDUTE / ASSISES / SITZMÖBEL

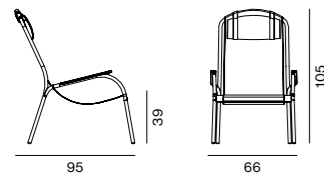

LULUPOG Iron armchair with wooden armrests, dove grey polypropylene fabric
Poltrona in ferro con braccioli in legno, tessuto polipropilene tortora / Fauteuil en fer avec tissu polypropylène taupe / Sessel aus Eisen mit taubengrauem Polypropylen Stoff

FINISHES / FINITURE / FINITIONS / AUSFÜHRUNGEN

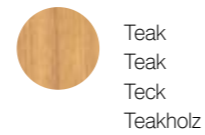
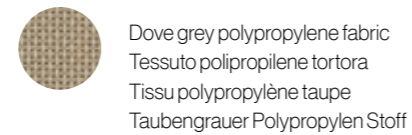
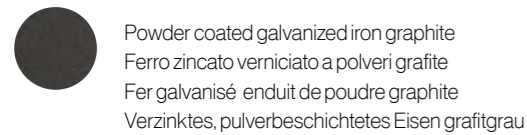

- Powder coated galvanized iron graphite / Ferro zincato verniciato a polveri grafite / Fer galvanisé enduit de poudre graphite
Verzinktes, pulverbeschichtetes Eisen grafitgrau
- Dove grey polypropylene fabric / Tessuto polipropilene tortora / Tissu polypropylène taupe / Taubengrauer Polypropylen Stoff

Nacre

SITTING / SEDUTE / ASSISES / SITZMÖBEL

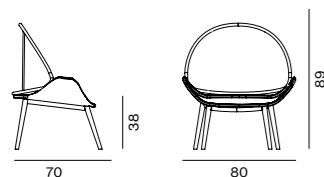

NASEDGR Armchair in aluminium and WaProLace® antique brown
Poltrona in alluminio e WaProLace® antique brown / Fauteuil en WaProLace® antique brown / Sessel aus WaProLace® antique brown

FINISHES / FINITURE / FINITIONS / AUSFÜHRUNGEN

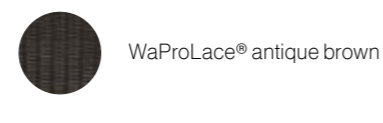

- Aluminum / Alluminio / Aluminium / Aluminium
- WaProLace® synthetic fibre / Fibra sintetica WaProLace® / Fibre synthétique WaProLace® / WaProLace® Synthetikfaser

Olimpia

LOUNGE / LOUNGE / LOUNGE / LOUNGE

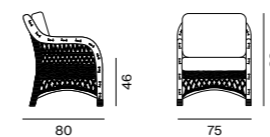

OLPOLW Armchair / Poltrona
Fauteuil / Sessel
OLCUPO Cushion / Cuscino
Coussin / Polster

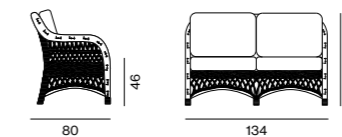

OLDIW2P Sofa / Divano
Canapé / Sofa
OLCUDI2P Cushion / Cuscino
Coussin / Polster

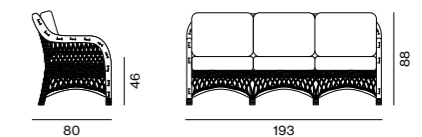

OLDIW3P Sofa / Divano
Canapé / Sofa
OLCUDI3P Cushion / Cuscino
Coussin / Polster

COFFEE TABLE / TAVOLO BASSO / TABLE BASSE / COUCHTISCH

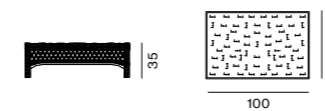

TABREOL Rectangular coffee table
Tavolo basso rettangolare
Table basse rectangulaire
Rechteckiger Couchtisch

FINISHES / FINITURE / FINITIONS / AUSFÜHRUNGEN

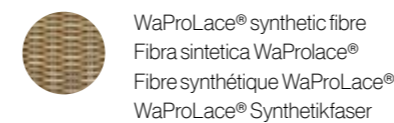

- Aluminum / Alluminio / Aluminium / Aluminium
- WaProLace® synthetic fibre / Fibra sintetica WaProLace® / Fibre synthétique WaProLace® / WaProLace® Synthetikfaser

Panarea

SUNLOUNGERS / LETTINI / BAINS DE SOLEIL / SONNENLIEGEN

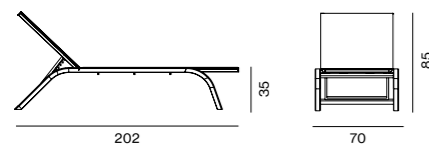

Sunlounger / Lettino / Bain de soleil / Sonnenliege

PANLEBB White / Bianco / Blanc / Weiß
PANLEGRM Graphite / Grafite / Graphite / Grafitgrau

TABLES / TAVOLI / TABLES / TISCHE

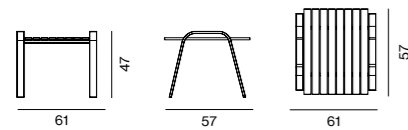

Coffee table / Tavolo basso / Table basse / Couchtisch

PANTBBI White / Bianco / Blanc / Weiß
PANTBGR Graphite / Grafite / Graphite / Grafitgrau

FINISHES / FINITURE / FINITIONS / AUSFÜHRUNGEN



Aluminum white
 Alluminio bianco
 Aluminium blanc
 Aluminium weiß



Aluminum graphite
 Alluminio grafite
 Aluminium graphite
 Aluminium grafitgrau



Hemp white technical fabric
 Tessuto tecnico bianco canapa
 Tissu technique blanc chanvre
 Technisches Gewebe naturweiß



Brown technical fabric
 Tessuto tecnico brown
 Tissu technique en marron
 Technisches Gewebe braun

→ Aluminum / Alluminio / aluminium / Aluminium

Pertre

TABLES / TAVOLI / TABLES / TISCHE



Square table with steel base / Tavolo quadrato con base in acciaio
 Table carrée avec base en acier / Quadratischer Tisch mit Stahlgestell

PERTAQU75AGR aluminum top / con piano in alluminio
 avec plateau en aluminium / mit Aluminiumplatte
PERTAQU75ATGR teak top / con piano in teak
 avec plateau en teck / mit Teakholzplatte

Square table with concrete base / Tavolo quadrato con base in cemento
 Table carrée avec base en ciment / Quadratischer Tisch mit Betonsockel

PERTAQU75ACGR aluminum top / con piano in alluminio
 avec plateau en aluminium / mit Aluminiumplatte
PERTAQU75ATCGR teak top / con piano in teak
 avec plateau en teck / mit Teakholzplatte

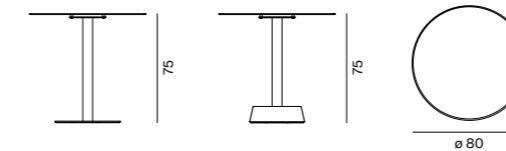

Round table with steel base / Tavolo rotondo con base in acciaio
 Table ronde avec base en acier / Runder Tisch mit Stahlgestell

PERTARO75AGR aluminum top / con piano in alluminio
 avec plateau en aluminium / mit Aluminiumplatte
PERTARO75ATGR teak top / con piano in teak
 avec plateau en teck / mit Teakholzplatte

Round table with concrete base / Tavolo rotondo con base in cemento
 Table ronde avec base en ciment / Runder Tisch mit Betonsockel

PERTARO75ACGR aluminum top / con piano in alluminio
 avec plateau en aluminium / mit Aluminiumplatte
PERTARO75ATCGR teak top / con piano in teak
 avec plateau en teck / mit Teakholzplatte

FINISHES / FINITURE / FINITIONS / AUSFÜHRUNGEN



Teak
 Teak
 Teck
 Teakholz



Powder coated galvanized iron graphite
 Ferro zincato verniciato a polveri grafite
 Fer galvanisé enduit de poudre grafite
 Verzinktes, pulverbeschichtetes Eisen grafitgrau



Concrete
 Cimento
 Ciment
 Beton

→ Teak / Teak / Teck / Teakholz
 → Aluminum / Alluminio / Aluminium / Aluminium
 → Concrete / Cimento / Ciment / Beton

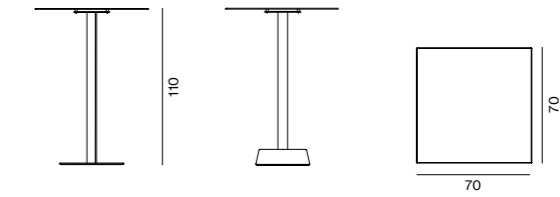

High square table with steel base / Tavolo alto quadrato con base in acciaio
 Table haute carrée avec base en acier / Hoher quadratischer Tisch mit Stahlgestell

PERTAQU110AGR aluminum top / con piano in alluminio
 avec plateau en aluminium / mit Aluminiumplatte
PERTAQU110ATGR teak top / con piano in teak
 avec plateau en teck / mit Teakholzplatte

High square table with concrete base / Tavolo alto quadrato con base in cemento
 Table haute carrée avec base en ciment / Hoher quadratischer Tisch mit Betonsockel

PERTAQU110ACGR aluminum top / con piano in alluminio
 avec plateau en aluminium / mit Aluminiumplatte
PERTAQU110ATCGR teak top / con piano in teak
 avec plateau en teck / mit Teakholzplatte

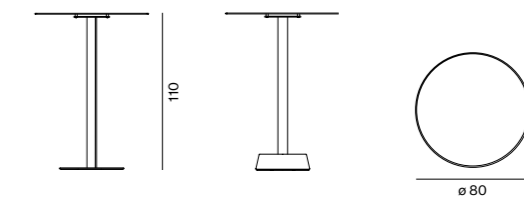

High round table with steel base / Tavolo alto rotondo con base in acciaio
 Table haute ronde avec base en acier / Hoher runder Tisch mit Stahlgestell

PERTARO110AGR aluminum top / con piano in alluminio
 avec plateau en aluminium / mit Aluminiumplatte
PERTARO110ATGR teak top / con piano in teak
 avec plateau en teck / mit Teakholzplatte

High round table with concrete base / Tavolo alto rotondo con base in cemento
 Table haute ronde avec base en ciment / Hoher runder Tisch mit Betonsockel

PERTARO110ACGR aluminum top / con piano in alluminio
 avec plateau en aluminium / mit Aluminiumplatte
PERTARO110ATCGR teak top / con piano in teak
 avec plateau en teck / mit Teakholzplatte

Pevero

SITTING / SEDUTE / ASSISES / SITZMÖBEL

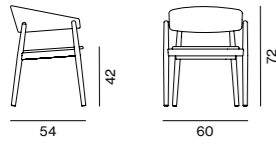

PEVSETC Small armchair in teak and cord
Poltroncina in teak e corda
Petit fauteuil en teck et corde
Armstuhl aus Teak und Seil

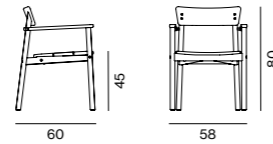

PEVSETE Small armchair / Poltroncina
Petit fauteuil / Armstuhl
CUPEVSE Cushion / Cuscino / Coussin / Kissen

FINISHES / FINITURE / FINITIONS / AUSFÜHRUNGEN



Teak
Teak
Teck
Teakholz

→ Teak / Teak / Teck / Teakholz

Salò

SITTING AND LOUNGE / SEDUTA E LOUNGE / ASSISES ET LOUNGE / LOUNGEMÖBEL

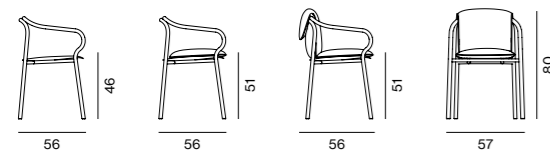

Chair / Sedia / Chaise / Stuhl

SASEDRU	Terracotta / Terracotta / Terracotta / Terracotta
SASEDGC	Graphite / Grafite / Graphite / Grafitgrau
SASEDVE	Sage / Salvia / Sauge / Salbeigrün
SASEDSA	Sand / Sabbia / Sable / Sand

Chair with seat cushion / Sedia con cuscino di seduta
Chaise avec coussins d'assise / Stuhl mit Sitzpolster

SASEDRUC	Terracotta / Terracotta / Terracotta / Terracotta
SASEDGC	Graphite / Grafite / Graphite / Grafitgrau
SASEDVEC	Sage / Salvia / Sauge / Salbeigrün
SASEDSAC	Sand / Sabbia / Sable / Sand

Chair with seat and backrest cushion / Sedia con cuscino di seduta e schienale
Chaise avec coussins d'assise et dossier / Stuhl mit Sitz- und Rückenpolster

SASEDRUSRC	Terracotta / Terracotta / Terracotta / Terracotta
SASEDGSRC	Graphite / Grafite / Graphite / Grafitgrau
SASEDVSRC	Sage / Salvia / Sauge / Salbeigrün
SASEDSASRC	Sand / Sabbia / Sable / Sand

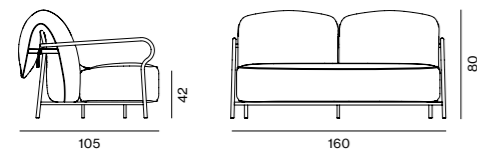

2-seater Sofa with seat and backrest cushion / Divano due posti con cuscino di seduta e schienale / Canapé 2 places avec coussins d'assise et dossier / Zweisitzer Sofa mit Sitz- und Rückenpolster

SADIV2RUC	Terracotta / Terracotta / Terracotta / Terracotta
SADIV2GC	Graphite / Grafite / Graphite / Grafitgrau
SADIV2VEC	Sage / Salvia / Sauge / Salbeigrün
SADIV2SAC	Sand / Sabbia / Sable / Sand

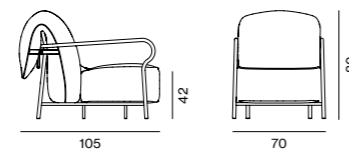

Armchair with seat and backrest cushion / Poltrona con cuscino di seduta e schienale
Fauteuil avec coussins d'assise et dossier / Sessel mit Sitz- und Rückenpolster

SAPOLRUC	Terracotta / Terracotta / Terracotta / Terracotta
SAPOLGC	Graphite / Grafite / Graphite / Grafitgrau
SAPOLVEC	Sage / Salvia / Sauge / Salbeigrün
SAPOLSAC	Sand / Sabbia / Sable / Sand

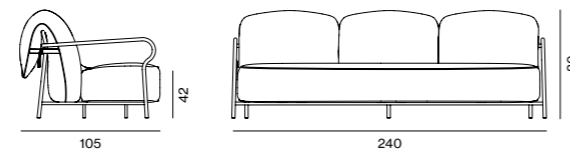

3-seater Sofa with seat and backrest cushion / Divano tre posti con cuscino di seduta e schienale / Canapé 3 places avec coussins d'assise et dossier / Dreisitzer Sofa mit Sitz- und Rückenpolster

SADIV3RUC	Terracotta / Terracotta / Terracotta / Terracotta
SADIV3GC	Graphite / Grafite / Graphite / Grafitgrau
SADIV3VEC	Sage / Salvia / Sauge / Salbeigrün
SADIV3SAC	Sand / Sabbia / Sable / Sand

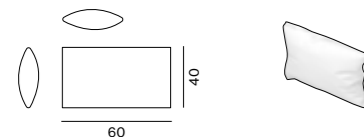

Lumbar cushion / Cuscino lombare
Coussin lombaire / Lendenkissen

SACULOMCRU	Terracotta piping / Piping terracotta / Passepoil en terre cuite / mit Paspel in Terracotta
SACULOMCGR	Graphite piping / Piping grafite / Passepoil en graphite / mit Paspel in Grafitgrau
SACULOMCVE	Sage piping / Piping salvia / Passepoil en sauge / mit Paspel in Salbeigrün
SACULOMCSA	Sand piping / Piping sabbia / Passepoil en sable / mit Paspel in Sand

→ Aluminum / Alluminio / Aluminium / Aluminium
→ Porcelain stone ware / Gres porcellanato / Grès cérame / Feinsteinzeug

TABLES / TAVOLI / TABLES / TISCHE

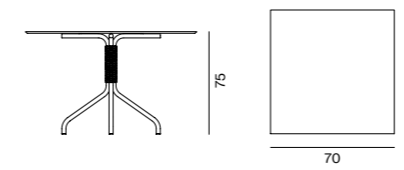

Square table / Tavolo quadrato / Table carrée / Quadratischer Tisch

Terracotta / Terracotta / Terracotta / Terracotta	
SATAQU70RU	with aluminum top / con piano in alluminio avec plateau en aluminium / mit Tischplatte aus Aluminium with porcelain stoneware top Terracotta, con piano gres porcellanato Terracotta, avec plateau grès cérame Terracotta mit Tischplatte aus Feinsteinzeug, Terracotta
SATAQUGR70RU	with porcelain stoneware top Deserto con piano gres porcellanato Deserto avec plateau grès cérame Deserto mit Tischplatte aus Feinsteinzeug, Deserto

Graphite / Grafite / Graphite / Grafitgrau	
SATAQU70G	with aluminum top / con piano in alluminio avec plateau en aluminium / mit Tischplatte aus Aluminium
SATAQUGR70G	with porcelain stoneware top Deserto con piano gres porcellanato Deserto avec plateau grès cérame Deserto mit Tischplatte aus Feinsteinzeug, Deserto

Sage / Salvia / Sauge / Salbeigrün	
SATAQU70VE	with aluminum top / con piano in alluminio avec plateau en aluminium / mit Tischplatte aus Aluminium
SATAQUGR70VE	with porcelain stoneware top Deserto con piano gres porcellanato Deserto avec plateau grès cérame Deserto mit Tischplatte aus Feinsteinzeug, Deserto

Sand / Sabbia / Sable / Sand	
SATAQU70SA	with aluminum top / con piano in alluminio avec plateau en aluminium / mit Tischplatte aus Aluminium
SATAQUGR70SA	with porcelain stoneware top Deserto con piano gres porcellanato Deserto avec plateau grès cérame Deserto mit Tischplatte aus Feinsteinzeug, Deserto

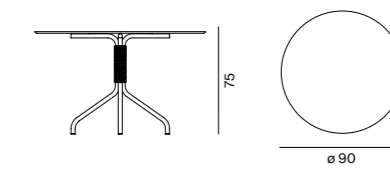

Round table / Tavolo rotondo / Table ronde / Runder Tisch

Terracotta / Terracotta / Terracotta / Terracotta	
SATARO90RU	with aluminum top / con piano in alluminio avec plateau en aluminium / mit Tischplatte aus Aluminium with porcelain stoneware top Terracotta, con piano gres porcellanato Terracotta, avec plateau grès cérame Terracotta mit Tischplatte aus Feinsteinzeug, Terracotta
SATAROGR90RU	with porcelain stoneware top Deserto con piano gres porcellanato Deserto avec plateau grès cérame Deserto mit Tischplatte aus Feinsteinzeug, Deserto

Graphite / Grafite / Graphite / Grafitgrau	
SATARO90G	with aluminum top / con piano in alluminio avec plateau en aluminium / mit Tischplatte aus Aluminium
SATAROGR90G	with porcelain stoneware top Deserto con piano gres porcellanato Deserto avec plateau grès cérame Deserto mit Tischplatte aus Feinsteinzeug, Deserto

Sage / Salvia / Sauge / Salbeigrün	
SATARO90VE	with aluminum top / con piano in alluminio avec plateau en aluminium / mit Tischplatte aus Aluminium
SATAROGR90VE	with porcelain stoneware top Deserto con piano gres porcellanato Deserto avec plateau grès cérame Deserto mit Tischplatte aus Feinsteinzeug, Deserto

Sand / Sabbia / Sable / Sand	
SATARO90SA	with aluminum top / con piano in alluminio avec plateau en aluminium / mit Tischplatte aus Aluminium
SATAROGR90SA	with porcelain stoneware top Deserto con piano gres porcellanato Deserto avec plateau grès cérame Deserto mit Tischplatte aus Feinsteinzeug, Deserto

→ Aluminum / Alluminio / Aluminium / Aluminium
→ Porcelain stone ware / Gres porcellanato / Grès cérame / Feinsteinzeug

Salò

TABLES / TAVOLI / TABLES / TISCHE

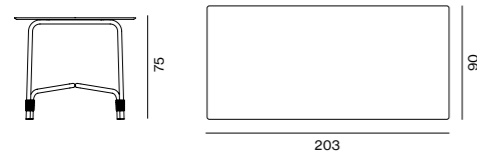

Rectangular table / Tavolo rettangolare
Table rectangulaire / Rechteckiger Tisch

Terracotta / Terracotta / Terracotta / Terracotta

SATAREPRU with aluminum top / con piano in alluminio
avec plateau en aluminium / mit Tischplatte aus Aluminium

SATAREPGRU with porcelain stoneware top Terracotta,
con piano gres porcellanato Terracotta,
avec plateau grès cérame Terracotta
mit Tischplatte aus Feinsteinzeug, Terracotta

Graphite / Grafite / Graphite / Grafitgrau

SATAREPG with aluminum top / con piano in alluminio
avec plateau en aluminium / mit Tischplatte aus Aluminium

SATAREPGRG with porcelain stoneware top Deserto
con piano gres porcellanato Deserto
avec plateau grès cérame Deserto
mit Tischplatte aus Feinsteinzeug, Deserto

Sage / Salvia / Sauge / Salbeigrün

SATAREPVE with aluminum top / con piano in alluminio
avec plateau en aluminium / mit Tischplatte aus Aluminium

SATAREPGRVE with porcelain stoneware top Deserto
con piano gres porcellanato top Deserto
avec plateau grès cérame Deserto
mit Tischplatte aus Feinsteinzeug, Deserto

Sand / Sabbia / Sable / Sand

SATAREPSA with aluminum top / con piano in alluminio
avec plateau en aluminium / mit Tischplatte aus Aluminium

SATAREPGRSA with porcelain stoneware top Deserto
con piano gres porcellanato Deserto
avec plateau grès cérame Deserto
mit Tischplatte aus Feinsteinzeug, Deserto

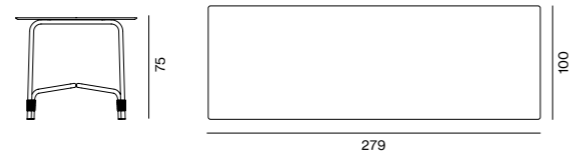

Rectangular table / Tavolo rettangolare
Table rectangulaire / Rechteckiger Tisch

Terracotta / Terracotta / Terracotta / Terracotta

SATAREGRU with aluminum top / con piano in alluminio
avec plateau en aluminium / mit Tischplatte aus Aluminium

SATAREGGRU with porcelain stoneware top Terracotta,
con piano gres porcellanato Terracotta,
avec plateau grès cérame Terracotta
mit Tischplatte aus Feinsteinzeug, Terracotta

Graphite / Grafite / Graphite / Grafitgrau

SATAREGG with aluminum top / con piano in alluminio
avec plateau en aluminium / mit Tischplatte aus Aluminium

SATAREGGRG with porcelain stoneware top Deserto
con piano gres porcellanato Deserto
avec plateau grès cérame Deserto
mit Tischplatte aus Feinsteinzeug, Deserto

Sage / Salvia / Sauge / Salbeigrün

SATAREGVE with aluminum top / con piano in alluminio
avec plateau en aluminium / mit Tischplatte aus Aluminium

SATAREGGRVE with porcelain stoneware top Deserto
con piano gres porcellanato Deserto
avec plateau grès cérame Deserto
mit Tischplatte aus Feinsteinzeug, Deserto

Sand / Sabbia / Sable / Sand

SATAREGSA with aluminum top / con piano in alluminio
avec plateau en aluminium / mit Tischplatte aus Aluminium

SATAREGGRSA with porcelain stoneware top Deserto
con piano gres porcellanato Deserto
avec plateau grès cérame Deserto
mit Tischplatte aus Feinsteinzeug, Deserto

TABLES / TAVOLI / TABLES / TISCHE

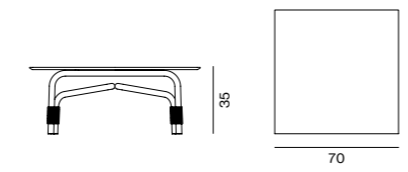

Square coffee table / Tavolo basso quadrato
Table basse carrée / Quadratischer Couchtisch

Terracotta / Terracotta / Terracotta / Terracotta

SATB70RU with aluminum top / con piano in alluminio
avec plateau en aluminium / mit Tischplatte aus Aluminium

SATB70GRRU with porcelain stoneware top Terracotta,
con piano gres porcellanato Terracotta,
avec plateau grès cérame Terracotta
mit Tischplatte aus Feinsteinzeug, Terracotta

Graphite / Grafite / Graphite / Grafitgrau

SATB70G with aluminum top / con piano in alluminio
avec plateau en aluminium / mit Tischplatte aus Aluminium

SATB70GRG with porcelain stoneware top Deserto
con piano gres porcellanato Deserto
avec plateau grès cérame Deserto
mit Tischplatte aus Feinsteinzeug, Deserto

Sage / Salvia / Sauge / Salbeigrün

SATB70VE with aluminum top / con piano in alluminio
avec plateau en aluminium / mit Tischplatte aus Aluminium

SATB70GRVE with porcelain stoneware top Deserto
con piano gres porcellanato Deserto
avec plateau grès cérame Deserto
mit Tischplatte aus Feinsteinzeug, Deserto

Sand / Sabbia / Sable / Sand

SATB70SA with aluminum top / con piano in alluminio
avec plateau en aluminium / mit Tischplatte aus Aluminium

SATB70GRSA with porcelain stoneware top Deserto
con piano gres porcellanato Deserto
avec plateau grès cérame Deserto
mit Tischplatte aus Feinsteinzeug, Deserto

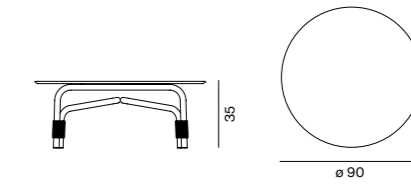

Round coffee table / Tavolo basso rotondo
Table basse ronde / Runder Couchtisch

Terracotta / Terracotta / Terracotta / Terracotta

SATB90RU with aluminum top / con piano in alluminio
avec plateau en aluminium / mit Tischplatte aus Aluminium

SATB90GRRU with porcelain stoneware top Terracotta,
con piano gres porcellanato Terracotta,
avec plateau grès cérame Terracotta
mit Tischplatte aus Feinsteinzeug, Terracotta

Graphite / Grafite / Graphite / Grafitgrau

SATB90G with aluminum top / con piano in alluminio
avec plateau en aluminium / mit Tischplatte aus Aluminium

SATB90GRG with porcelain stoneware top Deserto
con piano gres porcellanato Deserto
avec plateau grès cérame Deserto
mit Tischplatte aus Feinsteinzeug, Deserto

Sage / Salvia / Sauge / Salbeigrün

SATB90VE with aluminum top / con piano in alluminio
avec plateau en aluminium / mit Tischplatte aus Aluminium

SATB90GRVE with porcelain stoneware top Deserto
con piano gres porcellanato Deserto
avec plateau grès cérame Deserto
mit Tischplatte aus Feinsteinzeug, Deserto

Sand / Sabbia / Sable / Sand

SATB90SA with aluminum top / con piano in alluminio
avec plateau en aluminium / mit Tischplatte aus Aluminium

SATB90GRSA with porcelain stoneware top Deserto
con piano gres porcellanato Deserto
avec plateau grès cérame Deserto
mit Tischplatte aus Feinsteinzeug, Deserto

→ Aluminum / Alluminio / Aluminium / Aluminium
→ Porcelain stone ware / Gres porcellanato / Grès cérame / Feinsteinzeug

→ Aluminum / Alluminio / Aluminium / Aluminium
→ Porcelain stone ware / Gres porcellanato / Grès cérame / Feinsteinzeug

Salò

TABLES / TAVOLI / TABLES / TISCHE

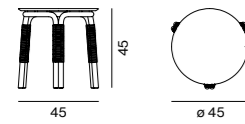

Round coffee table / Tavolo basso rotondo
Table basse ronde / Runder Beistelltisch

Terracotta / Terracotta / Terracotta / Terracotta

SASTRU with aluminum top
con piano in alluminio
avec plateau en aluminium
mit Tischplatte aus Aluminium

SASTGRRU with porcelain stoneware top Terracotta,
con piano gres porcellanato Terracotta,
avec plateau grès cérame Terracotta
mit Tischplatte aus Feinsteinzeug, Terracotta

Graphite / Grafite / Graphite / Grafitgrau

SASTG with aluminum top
con piano in alluminio
avec plateau en aluminium
mit Tischplatte aus Aluminium

SASTGRG with porcelain stoneware top Deserto
con piano gres porcellanato Deserto
avec plateau grès cérame Deserto
mit Tischplatte aus Feinsteinzeug, Deserto

Sage / Salvia / Sauge / Salbeigrün

SASTVE with aluminum top
con piano in alluminio
avec plateau en aluminium
mit Tischplatte aus Aluminium

SASTGRVE with porcelain stoneware top Deserto
con piano gres porcellanato Deserto
avec plateau grès cérame Deserto
mit Tischplatte aus Feinsteinzeug, Deserto

Sand / Sabbia / Sable / Sand

SASTSA with aluminum top
con piano in alluminio
avec plateau en aluminium
mit Tischplatte aus Aluminium

SASTGRSA with porcelain stoneware top Deserto
con piano gres porcellanato Deserto
avec plateau grès cérame Deserto
mit Tischplatte aus Feinsteinzeug, Deserto

SUNLOUNGERS / LETTINI / BAINS DE SOLEIL / SONNENLIEGEN

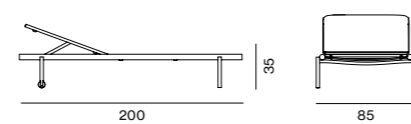

Sunlounger / Lettino / Bain de soleil / Sonnenliege

SALETRU Terracotta
Terracotta
Terre cuite
Terracotta

SACULETRU Cushion with headrest and piping in terracotta color
Cuscino con poggiatesta e piping colore terracotta
Coussin avec appui-tête et passepoil couleur terre cuite
Kissen mit Kopfstütze und Kissenpaspel in der Farbe Terracotta

SALETG Graphite
Grafite
Graphite
Grafitgrau

SACULETGR Cushion with headrest and piping in graphite color
Cuscino con poggiatesta e piping colore grafite
Coussin avec appui-tête et passepoil couleur graphite
Kissen mit Kopfstütze und Kissenpaspel in der Farbe Grafitgrau

SALETVE Sage
Salvia
Sauge
Salbei

SACULETVE Cushion with headrest and piping in sage color
Cuscino con poggiatesta e piping colore salvia
Coussin avec appui-tête et passepoil couleur sauge
Kissen mit Kopfstütze und Kissenpaspel in der Farbe Salbeigrün

SALE TSA Sand
Sabbia
Sable
Sand

SACULE TSA Cushion with headrest and piping in sand color
Cuscino con poggiatesta e piping colore sabbia
Coussin avec appui-tête et passepoil couleur sable
Kissen mit Kopfstütze und Kissenpaspel in der Farbe Sand

Salò

SITTING / SEDUTE / ASSISES / SITZMÖBEL

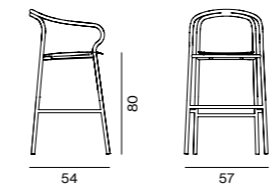

Stool with backrest / Sgabello con schienale
Tabouret avec dossier / Hocker mit Rückenlehne

SASGARU Terracotta / Terracotta / Terracotta / Terracotta
SASGAGR Graphite / Grafite / Graphite / Grafitgrau
SASGAVE Sage / Salvia / Sauge / Salbeigrün
SASGASA Sand / Sabbia / Sable / Sand

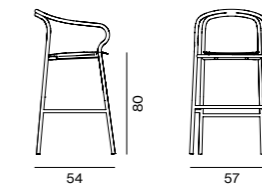

Stool with backrest and seat cushion / Sgabello con schienale e cuscino di seduta
Tabouret avec dossier et coussin d'assise / Hocker mit Rückenlehne und Sitzkissen

SASGARU Cushion with piping in terracotta color
Cuscino con piping colore terracotta
Coussin avec passepoil couleur terre cuite
Kissen mit Kissenpaspel in der Farbe Terracotta

SASGAGR Cushion with piping in graphite color
Cuscino con piping colore grafite
Coussin avec a passepoil couleur graphite
Kissen mit Kissenpaspel in der Farbe Grafitgrau

SASGAVE Cushion with piping in sage color
Cuscino con piping colore salvia
Coussin avec passepoil couleur sauge
Kissen mit Kissenpaspel in der Farbe Salbeigrün

SASGASA Cushion with piping in sand color
Cuscino con piping colore sabbia
Coussin avec passepoil couleur sable
Kissen mit Kissenpaspel in der Farbe Sand

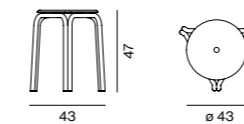

Low stool / Sgabello basso
Tabouret bas / Niedriger Hocker

SASGAPRU Terracotta / Terracotta / Terracotta / Terracotta
SASGAPGR Graphite / Grafite / Graphite / Grafitgrau
SASGAPVE Sage / Salvia / Sauge / Salbeigrün
SASGAPSA Sand / Sabbia / Sable / Sand

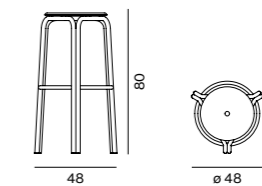

Tall stool / Sgabello alto
Tabouret haut / Hoher Hocker

SASGAGRU Terracotta / Terracotta / Terracotta / Terracotta
SASGAGGR Graphite / Grafite / Graphite / Grafitgrau
SASGAGVE Sage / Salvia / Sauge / Salbeigrün
SASGAGSA Sand / Sabbia / Sable / Sand

→ Aluminum / Alluminio / Aluminium / Aluminium
→ Porcelain stone ware / Gres porcellanato / Grès cérame / Feinsteinzeug

→ Aluminum / Alluminio / Aluminium / Aluminium
→ Porcelain stone ware / Gres porcellanato / Grès cérame / Feinsteinzeug

Salò

TABLES / TAVOLI / TABLES / TISCHE

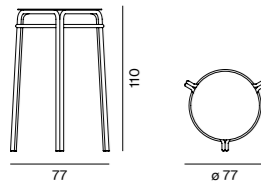

Tall round table / Tavolo alto rotondo
Table haute ronde / Hoher runder Tisch

SATAVALRU Terracotta / Terracotta / Terracotta / Terracotta

SATAVALGR Graphite / Grafite / Graphite / Grafitgrau

SATAVALVE Sage / Salvia / Saugé / Salbeigrün

SATAVALSA Sand / Sabbia / Sable / Sand

FINISHES / FINITURE / FINITIONS / AUSFÜHRUNGEN



Aluminum graphite
Alluminio grafite
Aluminium graphite
Aluminium grafitgrau



Porcelain stoneware Deserto
Gres porcellanato Deserto
Grès cérame Deserto
Feinsteinzeug Deserto



Aluminium sand
Alluminio sabbia
Aluminium sable
Aluminium sandfarben



Porcelain stoneware Terracotta
Gres porcellanato Terracotta
Grès cérame Terracotta
Feinsteinzeug Terracotta



Aluminum sage green
Alluminio verde salvia
Aluminium vert sauge
Aluminium salbeigrün



Sand fabric Batyline Serge Ferrari
Telo Batyline Serge Ferrari sabbia
Tissu sable en Batyline Serge Ferrari
Sandfarbene Bespannung in Batyline Serge Ferrari



Aluminum terracotta
Alluminio terracotta
Aluminium terracotta
Aluminium terracotta



Polypropylene cord ecru
Corda polipropilene ecru
Corde polypropylène écru
Polipropylen-Seil Farbe ecru

→ Aluminum / Alluminio / Aluminium / Aluminium

→ Porcelain stone ware / Gres porcellanato / Grès cérame / Feinsteinzeug

Synthesis

SITTING / SEDUTE / ASSISES / SITZMÖBEL

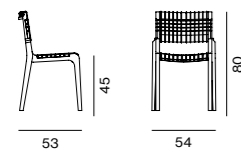

SESY Chair / Sedia / Chaise / Stuhl
SYSECU Cushion / Cuscino / Coussin
 Kissen

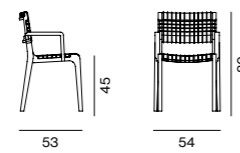

POSY Small armchair / Poltroncina
 Petit fauteuil / Armstuhll
SYSECU Cushion / Cuscino / Coussin
 Kissen

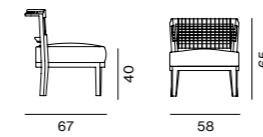

SYPB Small armchair
 Poltroncina bassa
 Petit fauteuil bas
 Niedriger Sessel
SYCUPB Cushion / Cuscino / Coussin
 Kissen

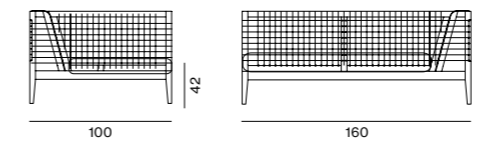

SYANS L corner module / Modulo angolo sx
 Module d'angle g / Eckmodul links
SYCUAN Cushion / Cuscino / Coussin / Sitzpolster

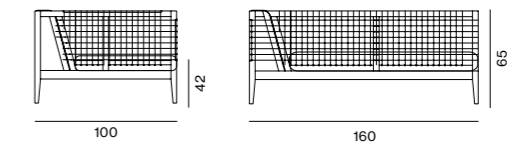

SYAND R corner module / Modulo angolo dx
 Module d'angle d / Eckmodul rechts
SYCUAN Cushion / Cuscino / Coussin / Sitzpolster

LOUNGE / LOUNGE / LOUNGE / LOUNGE

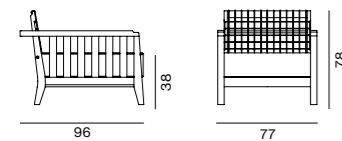

SYPO Armchair / Poltrona
 Fauteuil / Sessel
SYCUSE Cushion / Cuscino / Coussin
 Sitzpolster

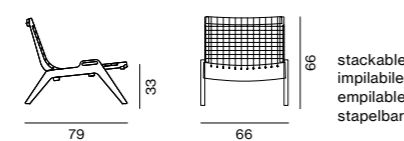

POLOS Lounge armchair
 Poltrona lounge
 Fauteuil lounge
 Loungesessel
SYPOCU Cushion / Cuscino / Coussin
 Sitzpolster

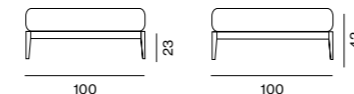

SYP Pouf / Pouf / Pouf / Hocker
SYCUPU Cushion / Cuscino
 Coussin / Sitzpolster

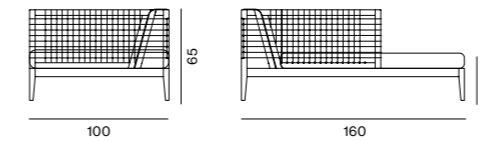

SYCHS L chaise-longue module / Modulo chaise-longue sx
 Module chaise longue g / Chaiselongue Modul links
SYCUCLS Cushion / Cuscino / Coussin / Sitzpolster

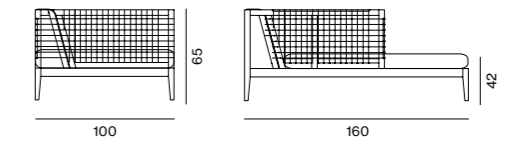

SYCHD R chaise-longue modulee / Modulo chaise-longue dx
 Module chaise longue d / Chaiselongue Modul rechts
SYCUCLD Cushion / Cuscino / Coussin / Sitzpolster

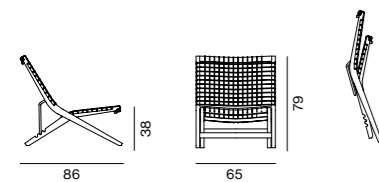

SDRASY Deckchair folding / Sdraio pieghevole
 Transat pliant / Klappbarer Liegestuhl
SYSDCU Cushion / Cuscino / Coussin / Kissen

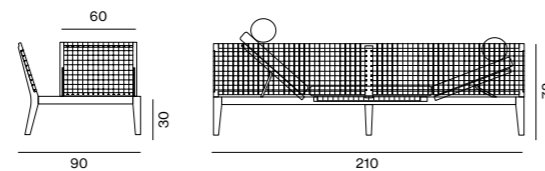

SYLD Sofa-bed adjustable seat on both sides
 Divano-lettino con seduta regolabile su entrambi i lati
 Canapé lit réglable des 2 côtés / Bettsofa mit beidseitig
 verstellbaren Sitzflächen
SYCULD Cushion / Cuscino / Coussin / Sitzpolster

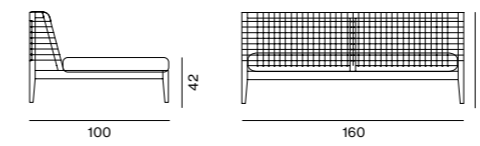

SYSP Backrest module / Modulo spalla
 Module dossier / Rückenlehnmodul
SYCUSP Cushion / Cuscino / Coussin / Sitzpolster

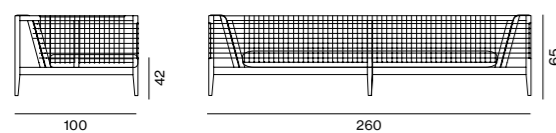

SYDIG Sofa / Divano / Canapé / Sofa
SYCUDIG Cushion / Cuscino
 Coussin / Sitzpolster

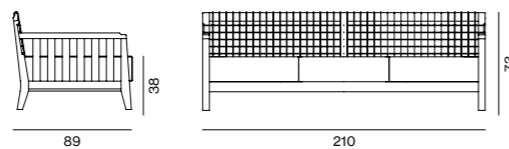

SYDI Sofa / Divano / Canapé / Sofa
SYCUSE Cushion / Cuscino
 Coussin / Sitzpolster

→ Teak / Teak / Teck / Teakholz
 → Synthetic fibre WaProLace® / Fibra sintetica WaProLace® / Fibre synthétique WaProLace® / WaProLace® Synthetikfaser

→ Teak / Teak / Teck / Teakholz
 → Synthetic fibre WaProLace® / Fibra sintetica WaProLace® / Fibre synthétique WaProLace® / WaProLace® Synthetikfaser

Synthesis

TABLES / TAVOLI / TABLES / TISCHE

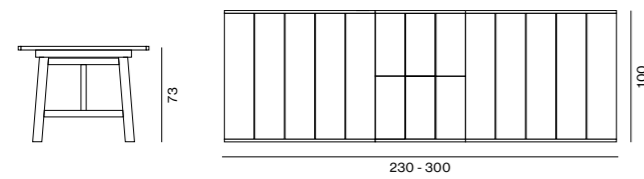

TATSY Rectangular table extendable / Tavolo allungabile rettangolare
Table allongeable rectangulaire / Rechteckiger Ausziehtisch

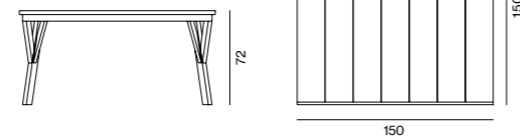

TASYQU Square table / Tavolo quadrato
Table carrée / Quadratischer Tisch

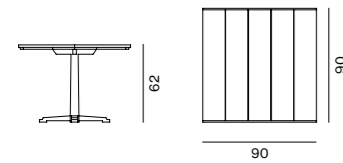

TASYQB Square table / Tavolo quadrato
Table carrée / Quadratischer Tisch

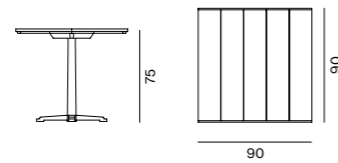

TAQULESY Square table / Tavolo quadrato
Table carrée / Quadratischer Tisch

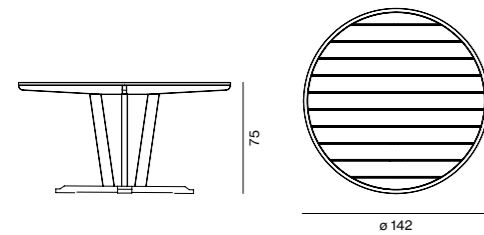

SYTARO Round table / Tavolo rotondo
Table ronde / Runder Tisch

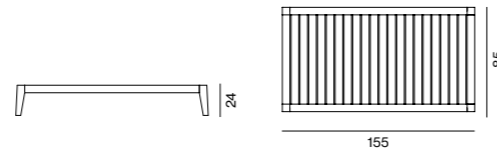

SYTABR Rectangular coffee table / Tavolo basso rettangolare
Table basse rectangulaire / Rechteckiger Couchtisch

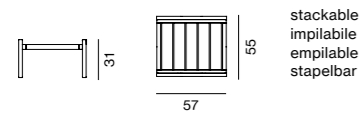

SYTABQM Square coffee table with handles
Tavolo basso quadrato con maniglie
Table basse carrée avec poignées
Quadratischer Couchtisch mit Griffen

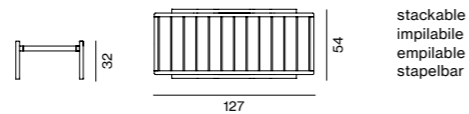

SYTABRM Rectangular coffee table with handles
Tavolo basso rettangolare con maniglie
Table basse rectangulaire avec poignées
Rechteckiger Couchtisch mit Griffen

SUNLOUNGERS / LETTINI / BAINS DE SOLEIL / SONNENLIEGEN

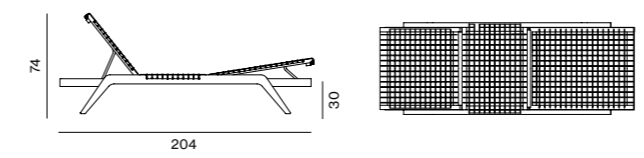

LESY Sunlounger / Lettino / Bain de soleil / Sonnenliege
SYLICU Cushion / Cuscino / Coussin / Polsterauflage

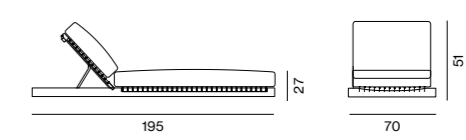

SYLEB Sunlounger low / Lettino basso
Bain de soleil bas / Niedrige Sonnenliege
SYCULEB Cushion / Cuscino / Coussin / Polsterauflage

ALCOVE / ALCOVA / ALCÔVE / ALKOVEN

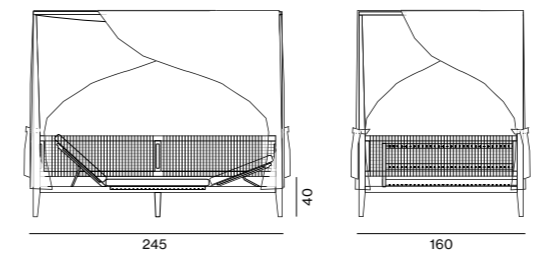

ALSYBI Alcove with adjustable seat base on both sides
Alcova con seduta regolabile su entrambi i lati
Alcôve avec base réglable des deux côtés
Alkoven mit beidseitig verstellbaren Sitzflächen

FINISHES / FINITURE / FINITIONS / AUSFÜHRUNGEN

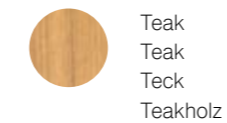

Teak
Teak
Teck
Teakholz



WaProLace® natural
WaProLace® naturale
WaProLace® naturel
WaProLace® Synthetikfaser

→ Teak / Teak / Teck / Teakholz
→ Synthetic fibre WaProLace® / Fibra sintetica WaProLace® / Fibre synthétique WaProLace® / WaProLace® Synthetikfaser

→ Teak / Teak / Teck / Teakholz
→ Synthetic fibre WaProLace® / Fibra sintetica WaProLace® / Fibre synthétique WaProLace® / WaProLace® Synthetikfaser

Swing

CHAISE LONGUE / CHAISE-LONGUE / CHAISE-LONGUE / CHAISLONGUE

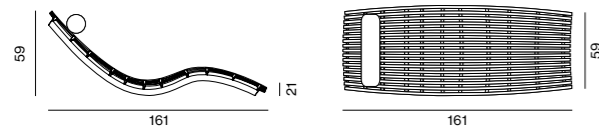

SWIDO Chaise longue / Chaise-longue
Chaise-longue / Chaiselongue
CUSWIDO001 Headrest cushion / Cuscino poggiatesta
Coussin d'appui-tête / Nackenrolle

STOOL / SGABELLO / TABOURET / HOCKER

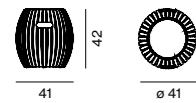

SGANTE Stool / Sgabello / Tabouret / Hocker

FINISHES / FINITURE / FINITIONS / AUSFÜHRUNGEN



→ Teak / Teak / Teck / Teakholz
→ Stainless steel / Acciaio inox / Acier inoxydable / Edelstahl

Titanic

CHAISE LONGUE / CHAISE-LONGUE / CHAISE-LONGUE / CHAISLONGUE

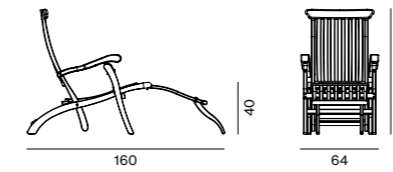

GRTIT Chaise longue / Chaise-longue / Chaise-longue / Chaiselongue
CUGT Cushion / Cuscino / Coussin / Polsterauflage

FINISHES / FINITURE / FINITIONS / AUSFÜHRUNGEN

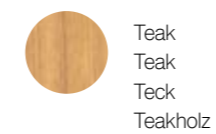

→ Teak / Teak / Teck / Teakholz

Toscana

SITTING / SEDUTE / ASSISES / SITZGELEGENHEITEN

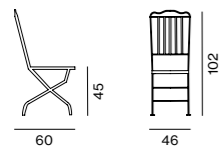

CASEG Chair / Sedia / Chaise / Stuhl
CUCAPSA Cushion / Cuscino / Coussin / Kissen

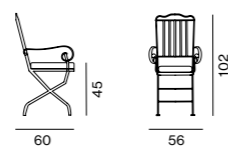

CAPOG Small armchair / Poltroncina
Petit fauteuil / Armstuhl
CUCAPSA Cushion / Cuscino / Coussin / Kissen

LOUNGE / LOUNGE / LOUNGE / LOUNGE

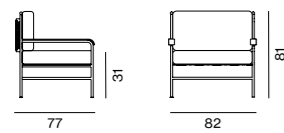

TOPO Armchair / Poltrona / Fauteuil / Sessel
TOPOCU Cushion / Cuscino / Coussin / Polster

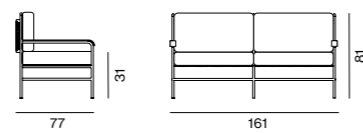

TODI Sofa / Divano / Canapé / Sofa
TODICU Cushion / Cuscino / Coussin / Polster

FINISHES / FINITURE / FINITIONS / AUSFÜHRUNGEN



Powder coated galvanized iron graphite
Ferro zincato verniciato a polveri grafite
Fer galvanisé enduit de poudre graphite
Verzinktes, pulverbeschichtetes Eisen grafitgrau

→ Powder coated galvanized iron / Ferro zincato verniciato a polveri / Fer galvanisé enduit de poudre / Verzinktes, pulverbeschichtetes Eisen

Treble

SITTING AND LOUNGE / SEDUTA E LOUNGE / ASSISES ET LOUNGE / LOUNGEMÖBEL

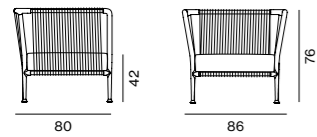

Armchair / Poltrona / Fauteuil / Sessel

TREPOA	Sand - white melange / Sabbia - bianco melange Sable - blanc mélangé / Sand - weiß meliert
TREPOGR	Graphite - white melange / Grafite - bianco melange Graphite - blanc mélangé / Grafitgrau - weiß meliert
TREPORU	Terracotta - white melange / Terracotta - bianco melange Terracotta - blanc mélangé / Terrakottafarben - weiß meliert
TREPOVS	Sage - green melange / Salvia - verde melange Sauge - vert mélangé / Salbeigrün - grün meliert
TRECUPO	Seat cushion / Cuscino di seduta / Coussin d'assise / Sitzpolster
TRECUSC	Cushion backrest / Cuscino schienale Coussin dossier / Rückenpolster

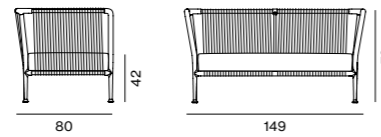

Sofa / Divano / Canapé / Sofa

TREDIA	Sand - white melange / Sabbia - bianco melange Sable - blanc mélangé / Sand - weiß meliert
TREDIGR	Graphite - white melange / Grafite - bianco melange Graphite - blanc mélangé / Grafitgrau - weiß meliert
TREDIRU	Terracotta - white melange / Terracotta - bianco melange Terracotta - blanc mélangé / Terrakottafarben - weiß meliert
TREDIVS	Sage - green melange / Salvia - verde melange Sauge - vert mélangé / Salbeigrün - grün meliert
TRECUSE	Seat cushion / Cuscino di seduta / Coussin d'assise / Sitzpolster
TRECUSC	Cushion backrest / Cuscino schienale Coussin dossier / Rückenpolster

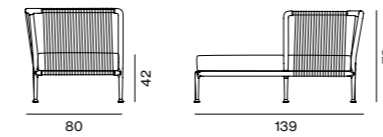

L chaise-longue module / Modulo chaise-longue sx
Module chaise longue g / Chaiselongue Modul links

TRELOSA	Sand - white melange / Sabbia - bianco melange Sable - blanc mélangé / Sand - weiß meliert
TRELOSGR	Graphite - white melange / Grafite - bianco melange Graphite - blanc mélangé / Grafitgrau - weiß meliert
TRELOSRU	Terracotta - white melange / Terracotta - bianco melange Terracotta - blanc mélangé / Terrakottafarben - weiß meliert
TRELOSVS	Sage - green melange / Salvia - verde melange Sauge - vert mélangé / Salbeigrün - grün meliert
TRECUSE	Seat cushion / Cuscino di seduta / Coussin d'assise / Sitzpolster
TRECUSC	Cushion backrest / Cuscino schienale Coussin dossier / Rückenpolster

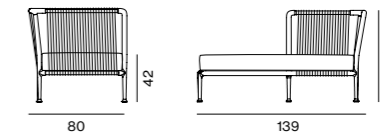

R chaise-longue module / Modulo chaise-longue dx
Module chaise longue d / Chaiselongue Modul rechts

TRELODA	Sand - white melange / Sabbia - bianco melange Sable - blanc mélangé / Sand - weiß meliert
TRELODGR	Graphite - white melange / Grafite - bianco melange Graphite - blanc mélangé / Grafitgrau - weiß meliert
TRELODRU	Terracotta - white melange / Terracotta - bianco melange Terracotta - blanc mélangé / Terrakottafarben - weiß meliert
TRELODVS	Sage - green melange / Salvia - verde melange Sauge - vert mélangé / Salbeigrün - grün meliert
TRECUSE	Seat cushion / Cuscino di seduta / Coussin d'assise / Sitzpolster
TRECUSC	Cushion backrest / Cuscino schienale Coussin dossier / Rückenpolster

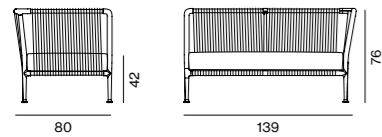

L corner module / Modulo angolo sx / Module d'angle g / Eckmodul links

TREANSA	Sand - white melange / Sabbia - bianco melange Sable - blanc mélangé / Sand - weiß meliert
TREANSGR	Graphite - white melange / Grafite - bianco melange Graphite - blanc mélangé / Grafitgrau - weiß meliert
TREANSRU	Terracotta - white melange / Terracotta - bianco melange Terracotta - blanc mélangé / Terrakottafarben - weiß meliert
TREANSVS	Sage - green melange / Salvia - verde melange Sauge - vert mélangé / Salbeigrün - grün meliert
TRECUSE	Seat cushion / Cuscino di seduta / Coussin d'assise / Sitzpolster
TRECUSC	Cushion backrest / Cuscino schienale Coussin dossier / Rückenpolster

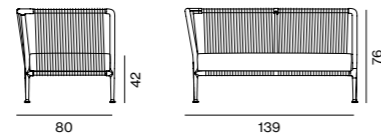

R corner module / Modulo angolo dx / Module d'angle d / Eckmodul rechts

TREANDA	Sand - white melange / Sabbia - bianco melange Sable - blanc mélangé / Sand - weiß meliert
TREANDGR	Graphite - white melange / Grafite - bianco melange Graphite - blanc mélangé / Grafitgrau - weiß meliert
TREANDRU	Terracotta - white melange / Terracotta - bianco melange Terracotta - blanc mélangé / Terrakottafarben - weiß meliert
TREANDVS	Sage - green melange / Salvia - verde melange Sauge - vert mélangé / Salbeigrün - grün meliert
TRECUSE	Seat cushion / Cuscino di seduta / Coussin d'assise / Sitzpolster
TRECUSC	Cushion backrest / Cuscino schienale Coussin dossier / Rückenpolster



Rectangular coffee table with top in teak / Tavolo basso rettangolare con piano in teak
Table basse rectangulaire avec plateau en teck / Rechteckiger Couchtisch mit Teakholzplatte

TRETABA	Sand / Sabbia / Sable / Sandfarben
TRETAGR	Graphite / Grafite / Graphite / Grafitgrau
TRETARU	Terracotta / Terrocotta / Terrocotta / Terrakottafarben
TRETABVS	Sage / Salvia / Vert sauge / Salbeigrün

FINISHES / FINITURE / FINITIONS / AUSFÜHRUNGEN

	Aluminum graphite Alluminio grafite Aluminium graphite Aluminium grafitgrau		Aluminum sage green Alluminio verde salvia Aluminium vert sauge Aluminium salbeigrün		Teak Teak Teck Teakholz
	Aluminium sand Alluminio sabbia Aluminium sable Aluminium sandfarben		Aluminum terracotta Alluminio terracotta Aluminium terracotta Aluminium terrakottafarben		Polypropylene cord white melange Corda polipropilene bianco melange Corde polypropylène blanc mélangé Seil aus Polypropylen weiß meliert
					Polypropylene cord green melange Corda polipropilene verde melange Corde polypropylène vert mélangé Seil aus Polypropylen grün meliert

- Aluminum / Alluminio / Aluminium / Aluminium
- Teak / Teak / Teck / Teakholz
- Polypropylene cord / Corda polipropilene / Corde en polypropylène / Seil aus Polypropylen

- Aluminum / Alluminio / Aluminium / Aluminium
- Teak / Teak / Teck / Teakholz
- Polypropylene cord / Corda polipropilene / Corde en polypropylène / Seil aus Polypropylen

Versilia

TABLES / TAVOLI / TABLES / TISCHE

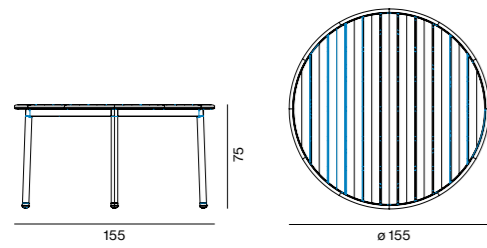

Round table with teak top and aluminum base
Tavolo rotondo con piano in teak e base in alluminio
Table ronde avec plateau en teck et base en aluminium
Runder Tisch mit Teakholzplatte und Aluminiumgestell

VERTAROGR Graphite / Grafite / Graphite / Grafitgrau
VERTAROCCI Chocolate / Cioccolato / Chocolat / Schokolade

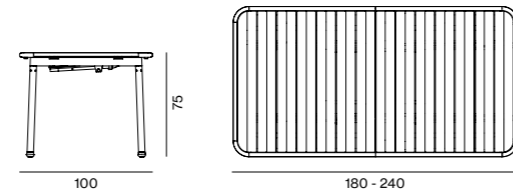

Rectangular extendable table with teak top and aluminum base
Tavolo rettangolare con piano in teak e base in alluminio
Table rectangulaire avec plateau en teck et base en aluminium
Rechteckiger Tisch mit Teakholzplatte und Aluminiumgestell

VERTAREALLGR Graphite / Grafite / Graphite / Grafitgrau
VERTAREALLCI Chocolate / Cioccolato / Chocolat / Schokolade

FINISHES / FINITURE / FINITIONS / AUSFÜHRUNGEN



Teak
Teak
Teck
Teakholz



Aluminum graphite
Alluminio grafite
Aluminium graphite
Aluminium grafitgrau



Aluminum Chocolate
Alluminio Cioccolato
Aluminium Chocolat
Aluminium Schokolade

→ Teak / Teak / Teck / Teakholz
→ Aluminum / Alluminio / Aluminium / Aluminium

Welcome

LOUNGE / LOUNGE / LOUNGE / LOUNGE

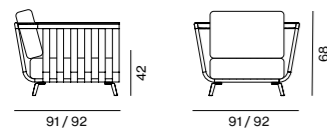

WELPO Armchair teak with seat and backrest cushions
Poltrona teak con cuscino di seduta e schienale
Fauteuil en teck avec coussins d'assise et dossier
Teakholzsessel mit Sitz- und Rückenpolster

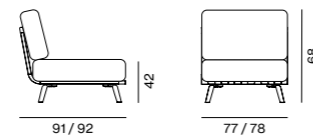

WELSPA Backrest module teak with seat and backrest cushions
Modulo spalla teak con cuscino di seduta e schienale
Module dossier en teck avec coussins d'assise et dossier
Rückenlehnmodul aus Teakholz mit Sitz- und Rückenpolster

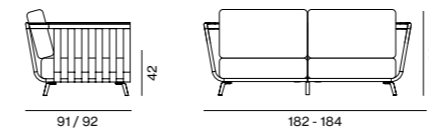

WEDIP Sofa teak with seat and backrest cushions
Divano teak con cuscino di seduta e schienale
Canapé en teck avec coussins d'assise et dossier
Sofa aus Teakholz mit Sitz- und Rückenpolster

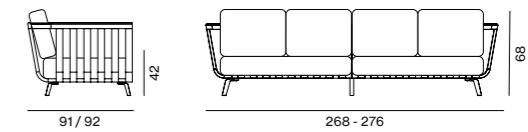

WEDIG Sofa teak with seat and backrest cushions
Divano teak con cuscino di seduta e schienale
Canapé en teck avec coussins d'assise et dossier
Sofa aus Teakholz mit Sitz- und Rückenpolster

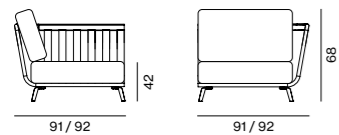

WA90S L module teak with seat and backrest cushions
Modulo sx teak con cuscino di seduta e schienale
Module g en teck avec coussins d'assise et dossier
Linkes Teakholzmodul mit Sitz- und Rückenpolster

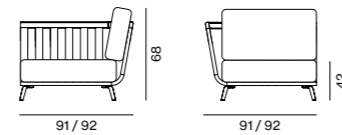

WA90D R module teak with seat and backrest cushions
Modulo dx teak con cuscino di seduta e schienale
Module d en teck avec coussins d'assise et dossier
Rechtes Teakholzmodul mit Sitz- und Rückenpolster

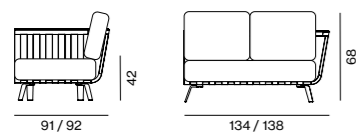

WA130S L module teak with seat and backrest cushions
Modulo sx teak con cuscino di seduta e schienale
Module g en teck avec coussins d'assise et dossier
Linkes Teakholzmodul mit Sitz- und Rückenpolster

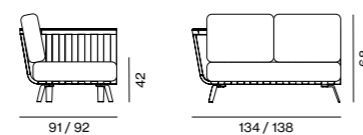

WA130D R module teak with seat and backrest cushions
Modulo dx teak con cuscino di seduta e schienale
Module d en teck avec coussins d'assise et dossier
Rechtes Teakholzmodul mit Sitz- und Rückenpolster

COFFEE TABLES / TAVOLINI / TABLE BASSE / COUCHTISCHE

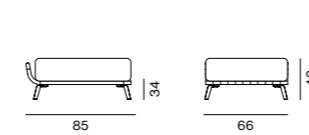

WELPU Pouf with seat cushion
Pouf con cuscino di seduta
Pouf avec coussin d'assise
Hocker mit Sitzpolster

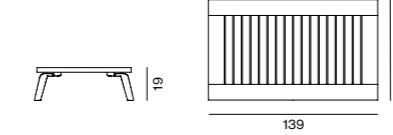

WELTABR Rectangular coffee table
Tavolo basso rettangolare
Table basse rectangulaire
Rechteckiger Couchtisch

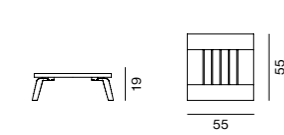

WELTABQ Square coffee table
Tavolo basso quadrato
Table basse carrée
Quadratischer Couchtisch

Add a WELCU63SC cushion for an L-shaped configuration.
Per la configurazione a L aggiungere un cuscino WELCU63SC.
Pour une configuration en L, ajouter un coussin WELCU63SC.
Für eine L-förmige Konfiguration fügen Sie ein Kissen WELCU63SC hinzu.

FINISHES / FINITURE / FINITIONS / AUSFÜHRUNGEN

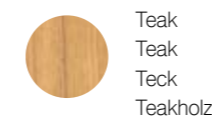

Teak
Teak
Teck
Teakholz



Aluminum bronze
Alluminio bronzo
Aluminium bronze
Aluminium bronze

- Teak / Teak / Teck / Teakholz
- Aluminum / Alluminio / Aluminium / Aluminium
- Polyolefin cord / Corda poliolefinica / Corde en polyoléfine / Polyolefin-Seil

William

SITTING / SEDUTE / ASSISES / SITZMÖBEL

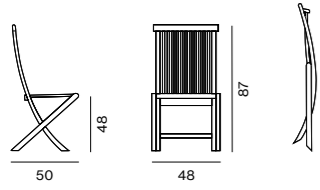

WILSED Chair William / Sedia William / Chaise William / Stuhl William
CUSEDA Cushion / Cuscino / Coussin / Kissen

FINISHES / FINITURE / FINITIONS / AUSFÜHRUNGEN



Teak
Teak
Teck
Teakholz

→ Teak / Teak / Teck / Teakholz

Sunshades
Technical
Sheets

Covercar
Dafne
Damian
Levante
Lipari
Manta
Meridienne
Nagi
Wood Garden
Orangerie
Salento
Shibuya
Solaire
Tibisco

Covercar

COVERCAR SINGLE / COVERCAR SINGOLO / COVERCAR SINGLE / EINZELCOVERCAR



W 393 D 450 H 255

W 393 D 578 H 255

COVERCAR DOUBLE / COVERCAR DOPPIO / COVERCAR DOUBLE / DOPPELCOVERCAR



W 709 D 450 H 255

W 709 D 578 H 255

Covercar / Covercar / Covercar / Covercar	W 393 D 450 H 255	COS45G
	W 393 D 578 H 255	COS60G
Double covercar / Covercar doppio / Covercar double / Doppelcovercar	W 709 D 450 H 255	COD45G
	W 709 D 578 H 255	COD60G
Single extension to widen COD45G Estensione singola per estendere in larghezza il COD45G Extension simple pour agrandir en largeur un covercar COD45G Erweiterung, um einem COD45G zu verbreitern	W 318 D 450 H 255	COD45GEX
Single extension to widen COD60G Estensione singola per estendere in larghezza il COD60G Extension simple pour agrandir en largeur un covercar COD60G Erweiterung, um einem COD60G zu verbreitern	W 318 D 578 H 255	COD60GEX

Fixing kit excluded / Kit di fissaggio escluso / kit de fixation exclu / Ohne Befestigungsmaterial

For the white finish add the letter 'W' in front of the article code e.g. WCOS45G

Per la finitura di colore bianco aggiungere la lettera "W" davanti al codice articolo es. WCOS45G

Pour la finition en blanc ajouter la lettre "W" devant le code de l'article, par exemple WCOS45G

Für die weiße Ausführung ergänzen Sie den Buchstaben "W" am Anfang der Artikelnummer, z.B. WCOS45G

The structure is in treated Nordic pine and can be painted in dark walnut, teak or in colours from the Unopiù Colour range. The structure can be enclosed using infill components the Wood Garden range. / La struttura è in pino nordico impregnato e può essere tinteggiata nelle tonalità noce scuro, teak o nei colori della linea Unopiù Color. / La struttura può essere chiusa con gli elementi del sistema Wood Garden. / La structure est en pin nordique traité et peut être teintée dans les tonalités noyer foncé, teak ou dans les couleurs de la ligne Unopiù Color. La structure peut être fermée avec les éléments de la ligne Wood Garden. / Die Struktur ist aus imprägniertem, nordischem Kiefernholz und kann mit den Farben dunkelbraun, teakholzfarben oder den Farben der Serie Unopiù Color angestrichen werden. Dazu passend gibt es die Elemente des Systems Wood Garden.

FINISHES / FINITURE / FINITIONS / AUSFÜHRUNGEN

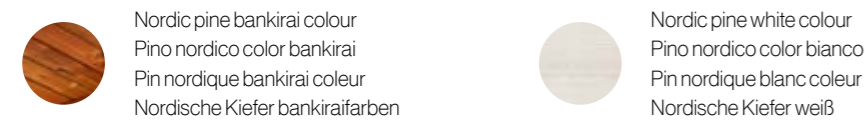

→ Nordic pine / Pino nordico / Pin nordique / Nordische Kiefer

Dafne

AWNING / PENSILINA / AUVENT / VORDACH

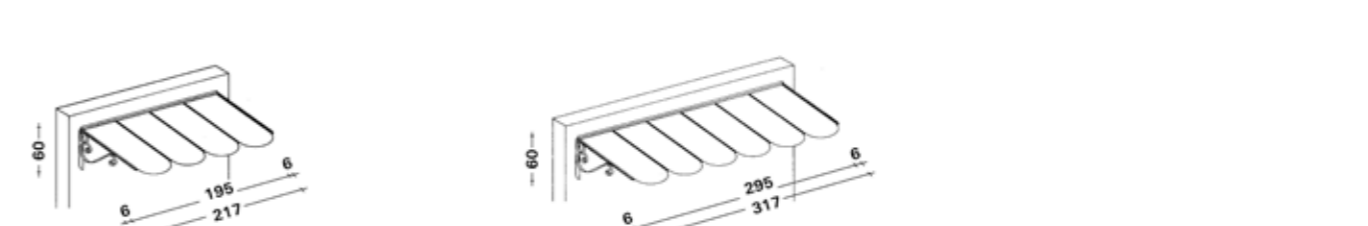

W 217 D 120 H 60

W 317 D 120 H 60

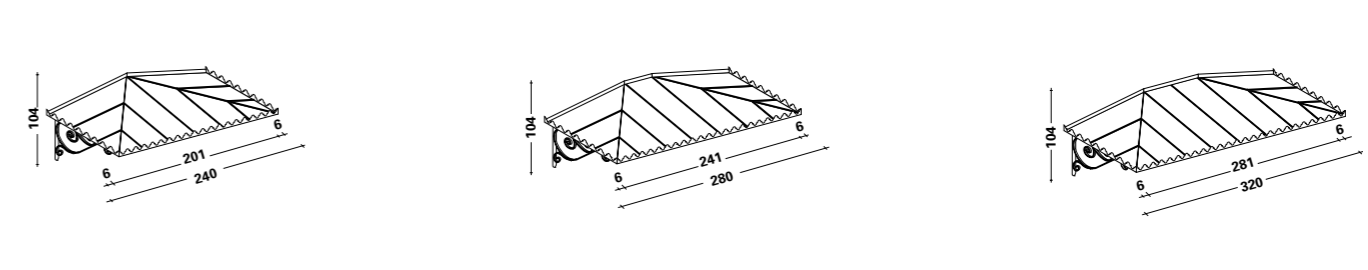

W 240 D 120 H 104

W 280 D 120 H 104

W 320 D 120 H 104

Awning / Pensilina / Auvent / Vordach	W 217 D 120 H 60	PEF200
	W 317 D 120 H 60	PEF300
Extension for PEF200 - PEF300 / Estensione per PEF200 - PEF300 Extension pour PEF200 - PEF300 / Erweiterung für PEF200 - PEF300	W 201 D 120 H 60	PEF200EX
	W 301 D 120 H 60	PEF300EX
Awning / Pensilina / Auvent / Vordach	W 240 D 120 H 104	PES240
	W 280 D 120 H 104	PES280
	W 320 D 120 H 104	PES320

Fixing kit excluded / Kit di fissaggio escluso / kit de excluded / Ohne Befestigungsmaterial

FINISHES / FINITURE / FINITIONS / AUSFÜHRUNGEN



→ Powder coated galvanized iron / Ferro zincato verniciato a polveri / Fer galvanisé enduit de poudre / Verzinktes, pulverbeschichtetes Eisen grafitgrau
→ Polycarbonate embossed / Policarbonato gofrato / Polycarbonate gaufré / Polycarbonat geprägt

Damian

UMBRELLAS / OMBRELLONI / PARASOLS / SONNENSCHIRME

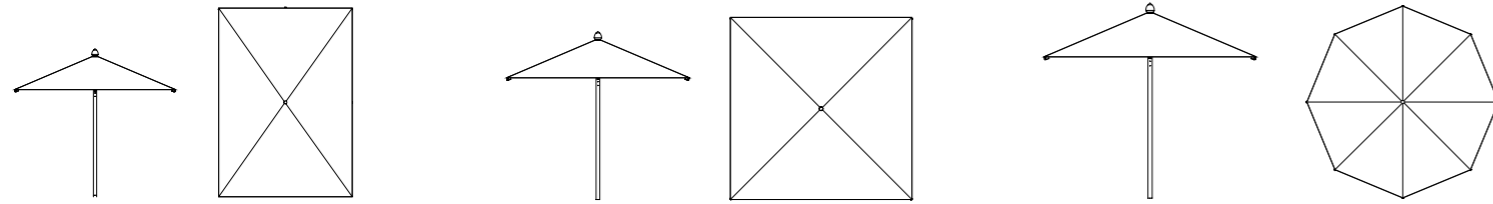



Ø 6 / 250 x 350 H 277

Ø 6 / 300 x 300 H 277

Ø 6 / Ø 350 H 277

Wood shafts Ø 6 / palo in legno Ø 6 / mât en bois Ø 6 / Holzmast Ø 6	250 x 350 H 277	300 x 300 H 277	Ø 350 H 277
Off white with blue border / Bianco grezzo bordino blu Blanc écri avec bordure bleue / Naturfarben mit blauem Rand	RE95BLU	QU98BLU	RO92BLU
Cord with brown border / Corda bordino marrone Corde avec bordure marron / Sandfarben mit braunem Rand	RE95MAR	QU98MAR	RO92MAR

FINISHES / FINITURE / FINITIONS / AUSFÜHRUNGEN

 100% acrylic off white 100% acrilico bianco grezzo 100% acrylique blanc écri 100% Baumwolle naturbelassen	 100% acrylic cord 100% acrilico corda 100% acrylique corde 100% Acryl sandfarben	 Solid wood Legno massello Bois massif Massivholz
------------------------------------------------------------------------------------------------------------------------------------------------------------------------------------------------------	-----------------------------------------------------------------------------------------------------------------------------------------------------------------------------	-----------------------------------------------------------------------------------------------------------------------------------------------

Riviera

UMBRELLAS / OMBRELLONI / PARASOLS / SONNENSCHIRME

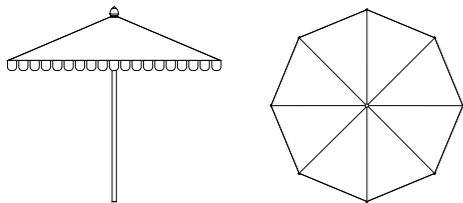

Ø 48 / Ø 250 H 277

Wood shafts Ø 48 / palo in legno Ø 48 / mât en bois Ø 48 / Holzmast Ø 48	Ø 250 H 277
Off white and ecru border / Bianco grezzo e bordino ecru / Blanc écri avec bordure écri / Naturbelassen mit Ecru-Kante	RO250MBI
Olive green and ecru border / Verde oliva e bordino ecru / Vert olive avec bordure écri / Olivgrün mit Ecru-Kante	RO250MVE

 Base plate 62 x 62 for Ø 48 mm shafts Piastra di base 62 x 62 per palo da Ø 48 mm Socle 62 x 62 pour mât de Ø 48 mm Bodenplatte 62 x 62 für Pfosten mit Ø 48 mm	White / Bianco / Blanc / Weiß	PI48B
	Graphite / Grafite Graphite / Grafitgrau	PI48G

FINISHES / FINITURE / FINITIONS / AUSFÜHRUNGEN

 100% acrylic off white and ecru border 100% acrilico bianco grezzo e bordino ecru 100% acrylique blanc avec bordure écri 100% Acryl naturbelassen mit Ecru-Kante	 100% acrylic olive green and ecru border 100% acrilico verde oliva e bordino ecru 100% acrylique vert olive avec bordure écri 100% Acryl olivgrün mit Ecru-Kante	 Solid wood Legno massello Bois massif Massivholz
---------------------------------------------------------------------------------------------------------------------------------------------------------------------------------------------------------------------------------------------------------------	---------------------------------------------------------------------------------------------------------------------------------------------------------------------------------------------------------------------------------------------------------------	-------------------------------------------------------------------------------------------------------------------------------------------------

→ Solid wood / Legno massello / Bois massif / Massivholz
→ Acrylic 100% / Acrilico 100% / 100% Acrylique / 100% Acryl

Levante

UMBRELLAS / OMBRELLONI / PARASOLS / SONNENSCHIRME

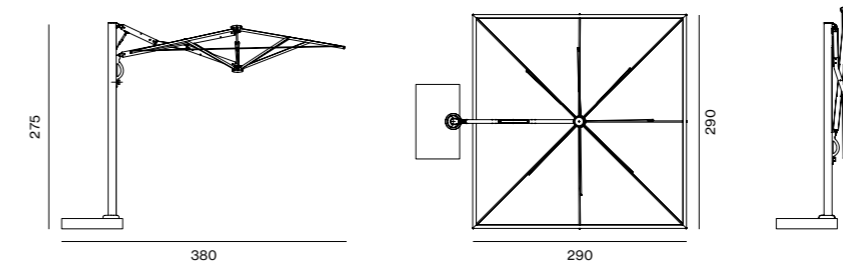

W 290 D 290 H 275/295

Aluminium parasol with titanium effect finish, graphite powder-coated galvanised steel base, motion opening, with fabric cover and 100% acrylic piping, Teflon resin-coated, water-repellent, water column approx. 25 cm - weight 350 g/m², mould- and bacteria-proof. Ombrellone in alluminio con finitura effetto titanium, base di acciaio zincato verniciato a polveri colore grafite, apertura motion, con telo in tessuto e piping 100% acrilico resinatura teflon, idro-oleorepellenza, colonna d'acqua circa 25 cm - grammatura 350 gr/m², inattaccabile da muffe e batteri

Parasol en aluminium avec finition effet titane, base en acier galvanisé revêtu de poudre graphite, ouverture à mouvement, avec housse en tissu et passepoil 100% acrylique, revêtu de résine téflon, hydrofuge, colonne d'eau d'environ 25 cm - poids 350 g/m², résistant aux moisissures et aux bactéries. Sonnenschirm aus Aluminium mit Titanium-Finish Effekt, galvanisiertes Stahlgestell mit Pulverbeschichtung in der Farbe grafitgrau, Motion-Öffnung, mit Stoffbezug und Einfassung aus 100% Acryl, teflonbeschichtet, wasserabweisend, Wassersäule ungefähr 25 cm - Gewicht 350g/m², Schimmel- und Bakterien-Resistent

Ecru OMBLEEC33

Parasol with high-brightness kit. Aluminium parasol with titanium effect finish, graphite powder-coated galvanised steel base, motion opening, with fabric cover and 100% acrylic piping, Teflon resin-coated, water-olepellency, water column approx. 25 cm - weight 350 g/m², mould- and bacteria-proof. Rechargeable battery with 8 h autonomy. Dimmable 3000k LED light with remote control. Complete wiring.

Ombrellone con kit alta luminosità. Ombrellone in alluminio con finitura effetto titanium, base di acciaio zincato verniciato a polveri colore grafite, apertura motion, con telo in tessuto e piping 100% acrilico resinatura teflon, idro-oleorepellenza, colonna d'acqua circa 25 cm - grammatura 350 gr/m², inattaccabile da muffe e batteria ricaricabile con autonomia 8 h. Luce led 3000k dimmerabile con telecomando remote control. Cablaggio completo.

Parasol en aluminium avec finition effet titane, base en acier galvanisé revêtu de poudre graphite, ouverture à mouvement, avec housse en tissu et passepoil 100% acrylique, revêtu de résine téflon, hydrofuge, colonne d'eau d'environ 25 cm - poids 350 g/m², résistant aux moisissures et aux bactéries. Batterie rechargeable avec une autonomie de 8 h. Lampe LED 3000k à variateur avec télécommande. Câblage complet.

Sonnenschirm mit Beleuchtungsset. Sonnenschirm aus Aluminium mit Titanium-Finish Effekt, galvanisiertes Stahlgestell mit Pulverbeschichtung in der Farbe grafitgrau, Motion-Öffnung, mit Stoffbezug und Einfassung aus 100% Acryl, teflonbeschichtet, wasser- und ölabweisend, Wassersäule ungefähr 25 cm - Gewicht 350 g/m², Schimmel- und Bakterien-Resistent. Wiederaufladbare Batterie mit 8 h Laufzeit. Dimmbares LED Licht mit 3000K mit Fernbedienung. Komplett verkabelt.



Ecru OMBLEEC33LED

ACCESSORIES / ACCESSORI / ACCESSOIRES / ZUBEHÖR

 Base cover in galvanised, titanium-coloured powder-coated steel. Carter di copertura della base in acciaio zincato e verniciato a polveri color titanio Couvercle de la base en acier galvanisé, revêtu de poudre couleur titane. Abdeckung für Gestell aus galvanisiertem Stahl, pulverbeschichtet in der Farbe Titanium.	OMBLEECARG
---------------------------------------------------------------------------------------------------------------------------------------------------------------------------------------------------------------------------------------------------------------------------------------------------------------------------------------------------------------------------------------------------------------------------	------------

 Set of 10 50 x 50 shot-blasted concrete tiles. Set di 10 mattonelle 50 x 50 di cemento granigliato Lot de 10 carreaux en béton grenailé de 50 x 50. Set mit 10 Betonsplittplatten 50x50 cm	BAOMLEV
-------------------------------------------------------------------------------------------------------------------------------------------------------------------------------------------------------------------------------------------------------------------------------------------	---------

FINISHES / FINITURE / FINITIONS / AUSFÜHRUNGEN

 Aluminium titanium finishing Alluminio finitura titanio Aluminium finition titane Aluminium mit Titanium-Finish	 Galvanized steel graphite Acciaio zincato color grafite Acier galvanisé couleur graphite Verzinktes Stahl grafitgrau
 100% acrylic ecru 100% acrilico ecru 100% acrylique écri 100% Acryl ecru	 Black piping Piping nero Passepoil noir schwarze Einfassung

→ Aluminium titanium finishing / Alluminio finitura titanio / Aluminium finition titane / Aluminium mit Titanium-Finish
→ Galvanized steel graphite / Acciaio zincato color grafite / Acier galvanisé couleur graphite / Verzinktes Stahl grafitgrau
→ Acrylic 100% / Acrilico 100% / 100% Acrylique / 100% Acryl

Lipari

RECTANGULAR UMBRELLAS / OMBRELLONI RETTANGOLARI / PARASOLS RECTANGULAIRES / RECHTECKIGE SCHIRME

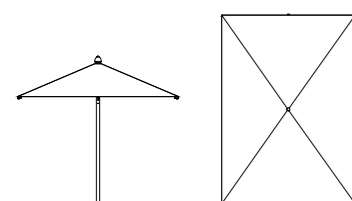

Ø 6 / 250 x 350 H 277 - 300 x 400 H 295

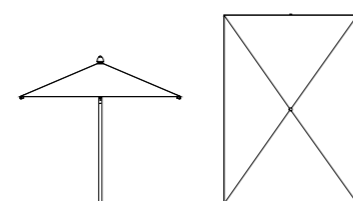

Ø 4 / 300 x 200 H 264

Wood shafts Ø 6 / palo in legno Ø 6 / mât en bois Ø 6 / Holzmast Ø 6	250 x 350 H 277	300 x 400 H 295
Off white / Bianco grezzo / Blanc écru / Naturfarben	RE95A	RE34A
Coffee / Caffé / Café / Kaffeefarben	RE95MA	RE34MA
Cord / Corda / Corde / Sandfarben	RE95CA	RE34CA
Rust / Ruggine / Rouille / Rostrot	RE95RUA	RE34RUA
Dove grey / Tortora / Tourterelle / Taubengrau	RE95TOA	RE34TOA
Aluminium shafts Ø 4 / Palo in alluminio Ø 4 / Mât en aluminium Ø 4 / Aluminiummast Ø 4		
(*) Off white / Bianco grezzo / Blanc écru / Naturfarben		OMSUREB
(*) Cord / Corda / Corde / Sandfarben		OMSUREC

(*) Polyester 100% / Poliestere 100% / Polyester 100% / 100% Polyester

SQUARE UMBRELLAS / OMBRELLONI QUADRATI / PARASOLS CARRÉS / QUADRATISCHE SCHIRME

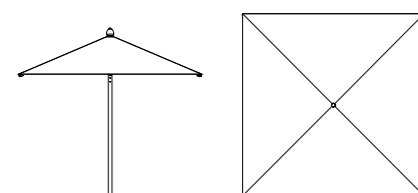

Ø 6 / 300 x 300 H 277 - 400 x 400 H 322

Wood shafts Ø 6 / Palo in legno Ø 6 / Mât en bois Ø 6 / Holzmast Ø 6	300 x 300 H 277	400 x 400 H 322
Off white / Bianco grezzo / Blanc écru / Naturfarben	QU98A	QU4A
Coffee / Café / Café / Kaffeefarben	QU98MA	QU4MA
Cord / Corda / Corde / Sandfarben	QU98CA	QU4CA
Rust / Ruggine / Rouille / Rostrot	QU98RUA	QU4RUA
Dove grey / Tortora / Tourterell / Taubengrau	QU98TOA	QU4TOA

- Solid wood / Legno massello / Bois massif / Massivholz
- Aluminum / Alluminio / Aluminium / Aluminium
- Concrete / Cemento / Béton / Beton
- Acrylic 100% / Acrílico 100% / 100% Acrylique / 100% Acryl
- Polyester 100% / Poliestere 100% / Polyester 100% / 100% Polyester

ROUND UMBRELLAS / OMBRELLONI ROTONDI / PARASOLS RONDS / RUNDE SCHIRME

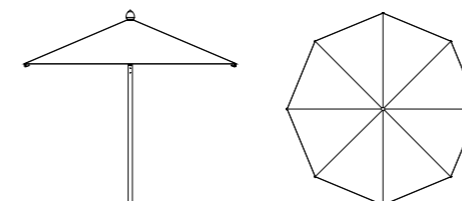

Ø 6 / Ø 350 H 277 - Ø 400 H 295

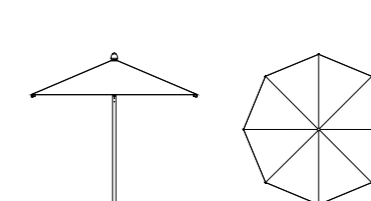

Ø 4 / Ø 280 H 254

Wood shafts Ø 6 / Palo in legno Ø 6 / Mât en bois Ø 6 / Holzmast Ø 6	Ø 350 H 277	Ø 400 H 295
Off white / Bianco grezzo / Blanc écru / Naturfarben	RO92A	RO4A
Coffee / Caffé / Café / Kaffeefarben	RO92MA	RO4MA
Cord / Corda / Corde / Sandfarben	RO92CA	RO4CA
Rust / Ruggine / Rouille / Rostrot	RO92RUA	RO4RUA
Dove grey / Tortora / Tourterelle / Taubengrau	RO92TOA	RO4TOA
Aluminium shafts Ø 4 / Palo in alluminio Ø 4 / Mât en aluminium Ø 4 / Aluminiummast Ø 4		
(*) Off white / Bianco grezzo / Blanc écru / Naturfarben		OMSUROB
(*) Cord / Corda / Corde / Sandfarben		OMSUROC

(*) Polyester 100% / Poliestere 100% / Polyester 100% / 100% Polyester

CONCRETE BASE / BASE IN CEMENTO / BASE EN BÉTON / BETONSTÄNDER



Concrete base with adjustable wood top with hole for umbrella (pole Ø 4)
 Base in cemento con piano regolabile in legno con foro per ombrellone (palo Ø 4)
 Base en béton et plateau réglable en bois avec trou pour parasol (mât Ø 4)
 Betonständer mit höhenverstellbarer Tischplatte aus Irokoholz, für Schirme (Mast Ø 4)

base Ø 45 top Ø 55 H 53 max.
 base Ø 45 piano Ø 55 H 53 max.
 base Ø 45 plateau Ø 55 H 53 max
 Unterteil Ø 45 Platte Ø 55 H 53 max

BAOMCEP

Concrete base with adjustable wood top with hole for umbrella (pole Ø 5 - 6)
 Base in cemento con piano regolabile in legno con foro per ombrellone (palo Ø 5 - 6)
 Base en béton et plateau réglable en bois avec trou pour parasol (mât Ø 5 - 6)
 Betonständer mit höhenverstellbarer Tischplatte aus Irokoholz, für Schirme (Mast Ø 5 - 6)





base Ø 70 top Ø 85 H 74 max.
 base Ø 70 piano Ø 85 H 74 max.
 base Ø 70 plateau Ø 85 H 74 max.
 Unterteil Ø 70 Platte Ø 85 H 74 max.

BAOMCEG

- Solid wood / Legno massello / Bois massif / Massivholz
- Aluminum / Alluminio / Aluminium / Aluminium
- Concrete / Cemento / Béton / Beton
- Acrylic 100% / Acrílico 100% / 100% Acrylique / 100% Acryl
- Polyester 100% / Poliestere 100% / Polyester 100% / 100% Polyester

Lipari

ACCESSORIES / ACCESSORI / ACCESSOIRES / ZUBEHÖR

	Base plate 62 x 62 in powder coated galvanized iron for umbrellas Piastra di base 62 x 62 ferro zincato verniciato a polveri per ombrelloni Socle 62 x 62 en fer galvanisé enduit de poudre pour parasol Schirmständer 62x62 cm aus galvanisiertem Eisen, pulverbeschichtet für Sonnenschirme	White / Bianco / Blanc / Weiß	PI62B
	Single umbrella sleeve Canotto singolo per ombrellone Adaptateur simple pour parasol Bodenhülse für einen Schirm	White / Bianco / Blanc / Weiß	PI62BCAN
	Ballast for umbrella base (15 kg) Zavorra per base ombrellone (Kg. 15) Contrepoids pour base parasol (Kg. 15) Ballast für Schirmständer (15 kg)	White / Bianco / Blanc / Weiß	PI62BZAV
	Kit of four feet in black for umbrella base Kit 4 piedini colore nero per base ombrellone Kit de 4 petits pieds couleur noir pour base parasol Set mit 4 schwarzen Füßen für Schirmständer		PIE4PI62
	Base plate Serena 40 x 40 35 kg with sleeve (to accommodate shafts max Ø 4) in galvanized iron - for OMSUREB / OMSUREC Base di pietra Serena 40 x 40 kg 35 con cannotto (predisposto per accogliere steli Ø max. 4) di ferro zincato - per OMSUREB / OMSUREC Socle en pierre Serena 40 x 40 kg 35 avec bague (prévue pour accueillir des mâts Ø max. 4) en fer galvanisé - pour OMSUREB / OMSUREC Schirmständer aus Serena-Stein 40x40 cm (35 kg) mit Metallrohr für Masten mit max. Ø 4 (OMSUREB / OMSUREC)		BASUN
	Waterproof cover dark green in 50% polyester and 50% PVC, for Umbrellas Ref. QU98 - RO92 - RO4 Copertura impermeabile verde scuro di poliestere 50% e PVC 50% per ombrelloni Art. QU98 - RO92 - RO4 Housse imperméable vert foncé en 50% polyester et 50% PVC pour parasol Réf. QU98 - RO92 - RO4 Schutzhülle dunkelgrün aus 50% Polyester und 50% PVC für Sonnenschirme Art. QU98 - RO92 - RO4		CO1
	Waterproof cover dark green in 50% polyester and 50% PVC, for Umbrellas Ref. RE95 - QU4 - RE34 Copertura impermeabile verde scuro di poliestere 50% e PVC 50% per ombrelloni Art. RE95 - QU4 - RE34 Housse imperméable vert foncé en 50% polyester et 50% PVC pour parasol Réf. RE95 - QU4 - RE34 Schutzhülle dunkelgrün aus 50% Polyester und 50% PVC für Sonnenschirme Art. RE95 - QU4 - RE34		CO2

The umbrellas can be completely disassembled. It is possible to substitute any element including the shade without changing the entire structure, as is the case with most umbrella brands.
Gli ombrelloni sono completamente smontabili. È possibile sostituire ogni elemento, compreso il telo, evitando di cambiare l'intera struttura, come avviene per gran parte degli ombrelloni in commercio.

Les parasols sont complètement démontables. Il est possible de remplacer chaque élément, toile comprise, évitant de remplacer l'entière structure comme pour la plupart des parasols en vente dans le commerce

Die Sonnenschirme können komplett zerlegt werden. Es ist daher möglich jedes Element auszutauschen, inklusive des Bezuges (ohne dabei die komplette Struktur zu verändern, wie es ansonsten bei den meisten Sonnenschirmen der Fall ist.)

- Solid wood / Legno massello / Bois massif / Massivholz
- Aluminum / Alluminio / Aluminium / Aluminium
- Concrete / Cemento / Béton / Beton
- Acrylic 100% / Acrilico 100% / 100% Acrylique / 100% Acryl
- Polyester 100% / Poliestere 100% / Polyester 100% / 100% Polyester

FINISHES / FINITURE / FINITIONS / AUSFÜHRUNGEN

	Aluminium graphite Alluminio grafite Aluminium graphite Aluminium grafitgrau		Concrete Cemento Béton Beton		Solid wood Legno massello Bois massif Massivholz
	100% acrylic off white 100% acrilico bianco grezzo 100% acrylique blanc écru 100% Baumwolle naturbelassen		100% acrylic cord 100% acrilico corda 100% acrylique corde 100% Acryl sandfarben		100% acrylic coffee 100% acrilico caffè 100% acrylique café 100% Acryl kaffefarben
	100% acrylic dove grey 100% acrilico tortora 100% acrylique gris torturelle 100% Acryl taubengrau		100% acrylic rust 100% acrilico ruggine 100% acrylique rouille 100% Acryl rostrot		
	100% polyester off white 100% poliestere bianco grezzo 100% polyester blanc 100% Polyester naturfarben		100% polyester cord 100% poliestere corda 100% polyester corde 100% Polyester sandfarben		

- Solid wood / Legno massello / Bois massif / Massivholz
- Aluminum / Alluminio / Aluminium / Aluminium
- Concrete / Cemento / Béton / Beton
- Acrylic 100% / Acrilico 100% / 100% Acrylique / 100% Acryl
- Polyester 100% / Poliestere 100% / Polyester 100% / 100% Polyester

Manta

HEXAGONAL / ESAGONALE / HEXAGONAL / SECHSECKIG

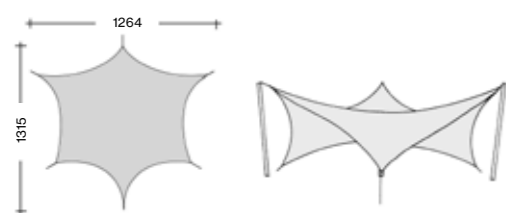

W 1264 D 1315

White PVC coated acrylic fabric / Tessuto acrilico spalmato di PVC bianco / Tissu acrylique enduit de PVC blanc
Acrylstoff mit weißer PVC-Beschichtung

Sail hexagonal including ropes, guy ropes, tension pegs and 3 lamellar wooden posts 9 x 9 H 400
Vela esagonale completa di cime, tiranti, picchetti tendicavo e 3 pali di legno lamellare 9 x 9 H 400
Voile hexagonale avec cordes, tirants, piquets tendeurs et 3 piliers en bois lamellé-collé 9 x 9 H 400
Segel sechseckig, komplett mit Seilen, Zugankern, Pflocken, Seilspannern und 3 Stützpfosten aus Schichtholz 9 x 9, H 400

W 1264 D 1315 MANTA

RHOMBOIDAL / ROMBOIDALE / VOILE LOSANGE / RAUTENFÖRMIG

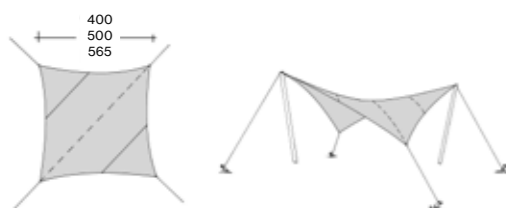

W 400 D 400 - W 500 D 500 - W 565 D 565

Acrylic fabric in écru / Tessuto acrilico écru / Tissu 100% acrylique de couleur écru / Weißer Acrylstoff

Sail rhomboidal including ropes, guy ropes, tension pegs and 2 wooden posts Ø 6,8 H 300
Vela romboidale completa di cime, picchetti, tendicorda e 2 pali di legno Ø 6,8 H 300
Voile losange avec cordes, piquets, tendeurs et 2 piliers en bois Ø 6,8 H 300
Segel rautenförmig, komplett mit Seilen, Pflocken, Seilspannern und 2 Stützpfosten aus Holz Ø 6,8, H 300

W 400 D 400 VEL4L
W 500 D 500 VEL5L
W 565 D 565 VEL6L

FINISHES / FINITURE / FINITIONS / AUSFÜHRUNGEN

 Treated pine wood
Legno di pino impregnato
Bois de pin traité
Imprägniertes Kiefernholz

 White PVC coated acrylic fabric
Tessuto acrilico spalmato di PVC bianco
Tissu acrylique enduit de PVC blanc
Acrylstoff mit PVC-Beschichtung weiß

 Acrylic fabric écru
Tessuto acrilico écru
Tissu acrylique écru
Weißer Acrylstoff

→ Treated pine wood / Legno di pino impregnato / Bois de pin traité / Imprägniertes Kiefernholz
→ White PVC coated acrylic fabric / Tessuto acrilico spalmato di PVC bianco / Tissu acrylique enduit de PVC blanc
Acrylstoff mit PVC-Beschichtung weiß
→ Acrylic fabric écru / Tessuto acrilico écru / Tissu 100% acrylique écru / Weißer Acrylstoff

Méridienne

WALL-MOUNTED PERGOLA WITHOUT A ROOF / PERGOLA ADDOSSATA SENZA COPERTURA
PERGOLA ADOSÉE SANS COUVERTURE / ANBAUPERGOLA OHNE DACH

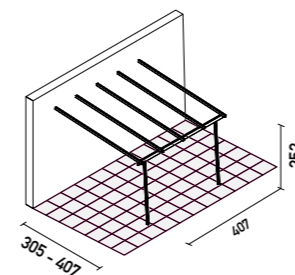

W 407 D 305 - 407

Extension / Estensione / Extension / Erweiterung

W 407 - Pergola / Pergola / Pergola / Pergola

W 204 - Extension / Estensione / Extension / Erweiterung

D 305 PEME43

D 305 ESPEME43

D 407 PEME44

D 407 ESPEME44

ROLL SHADES / TELI SCORREVOLI / TOILES COULISSANTES / FEDERZUGROLLOS

Kit for adjustable shade in 100% acrylic, colour écru complete with powder coated aluminium casing, spring retractable mechanism with tracks, for attached pergolas and extensions / Kit telo regolabile di acrilico 100% colore écru, completo di coprirullo di alluminio verniciato a polveri, avvolgibile a molla e guide, per pergole addossate ed estensioni / Kit toile réglable en 100% acrylique couleur écru avec coffre pour rouleau en aluminium thermolaqué, enrouleur à ressort et glissières, pour pergolas adossées et extensions. / Bausatz für verschiebbare Bespannung aus 100% naturfarbenem Acrylstoff, komplett mit grafitgrau beschichteter Blende aus Aluminium, Federmechanik und Schienen für Anbaupergolen und Erweiterungen.

Structure / Struttura / Structures / Pergolen

W 372 D 400 (Pergola / Pergola / Pergola / Pergola) COR405

W 186 D 400 (Extension / Estensione / Extension / Erweiterung) CPR405E

BAMBOO SHADES / STUOIE DI CANNE DI BAMBÙ / NATTES EN CANNES DE BAMBOU / BAMBUSMATTEN

Kit for bamboo shades made with bamboo canes of varying diameter (from 1 cm to 2 cm each) connected with a stainless steel wire. The kit includes fitting components / Kit di stuoie realizzate con canne di bambù di sezione variabile (da cm 1 a cm 2 ca.) e unite da un filo passante di acciaio inox. Il kit sono completi di elementi di fissaggio / Kit de nattes réalisées en cannes de bambou de section variant de 1 cm à 2 cm environ et reliées par un fil en acier inoxydable. Eléments de fixation compris dans le kit. / Satz Bambusmatten gefertigt aus Bambusstäben mit variablem Schnittdurchmesser (von 1 cm bis ca. 2 cm), verbunden mit Inox-Edelstahldraht, komplett mit Befestigungsmaterial

Descrizione

Bamboo mat W 185 D 250 / Stuoia di bambù L 185 P 250 / Nattes en bambou L 185 P 250 / Bambusmatte B 185 T 250 BAMR

Structure / Struttura / Structures / Pergolen

ESPEME43, ESPEME44, ESPEME43, ESPEME44 COBAM2ME

PEME43, PEME43 COBAM3ME

PEME44, PEME44 COBAM4ME

Méridienne

WALL-MOUNTED PERGOLA WITH POLYCARBONATE ROOF / PERGOLA ADDOSSATA CON COPERTURA IN POLICARBONATO
 PERGOLA ADOSSÉE AVEC TOIT EN POLYCARBONATE / ANBAUPERGOLA MIT POLYCARBONATDACH

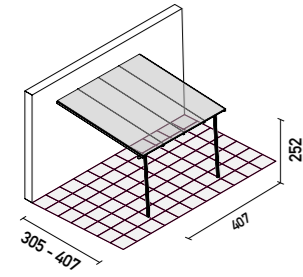

W 407 D 305 - 407

Extension / Estensione / Extension / Erweiterung

W 407 - Pergola / Pergola / Pergola / Pergola

W 204 - Extension / Estensione / Extension / Erweiterung

D 305	PEME43P
D 407	PEME44P

D 305	ESPEME43P
D 407	ESPEME44P

WALL-MOUNTED PERGOLA WITH SLATTED ROOFING / PERGOLA ADDOSSATA CON COPERTURA IN LAMELLE
 PERGOLA ADOSSÉE AVEC TOIT À LAMES ORIENTABLES / ANBAUPERGOLA MIT LAMELLENDACH

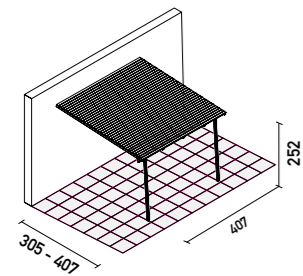

W 407 D 305 - 407

W 407 - Pergola / Pergola / Pergola / Pergola

D 305	PEME43F
D 407	PEME44F

FREESTANDING PERGOLA WITHOUT A ROOF / PERGOLA AUTOPORTANTE SENZA COPERTURA
 PERGOLA AUTOPORTANTE SANS COUVERTURE / FREISTEHENDE PERGOLA OHNE DACH

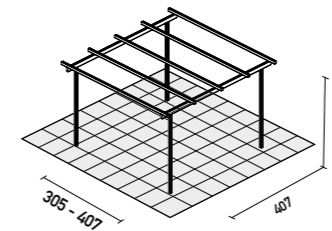

W 407 D 305 - 407

Extension / Estensione / Extension / Erweiterung

W 407 - Pergola / Pergola / Pergola / Pergola

W 204 - Extension / Estensione / Extension / Erweiterung

D 305	PEMEAUT43
D 407	PEMEAUT44

D 305	ESPEMEAUT43
D 407	ESPEMEAUT44

FREESTANDING PERGOLA WITH SLATTED ROOFING / PERGOLA AUTOPORTANTE CON COPERTURA IN LAMELLE
 PERGOLA AUTOPORTANTE AVEC TOIT À LAMES ORIENTABLES / FREISTEHENDE PERGOLA MIT LAMELLENDACH

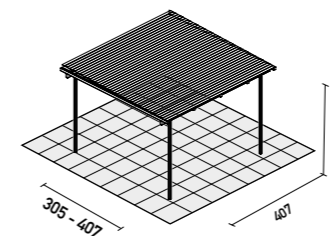







W 407 D 305 - 407

W 407 - Pergola / Pergola / Pergola / Pergola

D 305	PEMEAUT43F
D 407	PEMEAUT44F

Méridienne

FITTINGS / FISSAGGI / FIXATIONS / BEFESTIGUNGEN

	Additional aluminum post 6 x 6 H 240 Palo aggiuntivo in alluminio 6 x 6 H 240 Poteau supplémentaire en aluminium 6 x 6 H 240 Zusätzlicher Aluminiumpfosten 6 x 6 H 240	PIL6624CT
	Pair of angle brackets for fixing the additional post to the front beam Coppia di staffe angolari per il fissaggio del palo aggiuntivo alla trave frontale Paire d'équerres pour la fixation du poteau supplémentaire à la poutre frontale 2 Winkelhalter zur Befestigung des zusätzlichen Pfostens am vorderen Träger	STALME2
	Bracket for fixing the grid and the planter to the posts (4 brackets for the grid and 4 for the planter) Staffa per il fissaggio della griglia e della fioriera ai pali (4 staffe per la griglia e 4 per la fioriera) Support pour fixer le treillage et la jardinière aux poteaux (4 supports pour la grille et 4 pour la jardinière) Halterung zur Befestigung des Gitters und des Pflanzkübeln an den Pfosten (4 Halterungen für das Gitter und 4 für den Pflanzkübel)	STAPGMEC
	Bracket for fixing 4 x 4 cm posts to the ground Staffa per il fissaggio a terra di pilastri 4 x 4 cm Équerre pour fixer au sol les piliers 4 x 4 cm Pfostenschuh zur Befestigung der 4 x 4 Pfosten am Boden	STATME
	Pair of brackets for fixing 4 x 4 cm posts to parapet Coppia di staffe per il fissaggio al parapetto di pilastri 4 x 4 cm Paire d'équerres pour fixer piliers 4 x 4 cm à parapet 2 Profile zur Befestigung der 4 x 4 starken Pfosten an der Brüstung	STAPME2
	Pair of brackets for fixing 4 x 4 cm posts to railing Coppia di staffe per il fissaggio alla ringhiera di pilastri 4 x 4 cm Paire d'équerres pour fixer piliers 4 x 4 cm à la balustrade 2 Profile zur Befestigung der 4 x 4 starken Pfosten am Geländer	STARME2
	Kit of 4 components for fixing graphite iron grilles Kit di 4 elementi per fissaggio di grigliati in ferro Kit de 4 éléments pour fixer les treillages en fer, couleur graphite Set mit 4 Abstandhaltern für Rankgitter aus grafitgrauem Eisen	EFP4

Nagi

WALL-MOUNTED PERGOLA / PERGOLA ADDOSSATA / PERGOLA ADOSSÉE / ANBAUPERGOLA

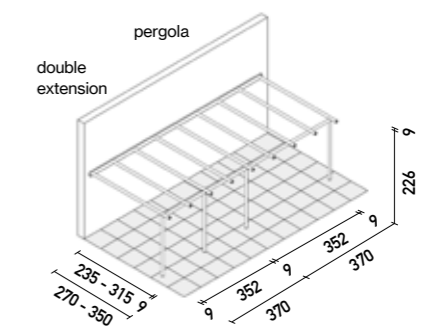
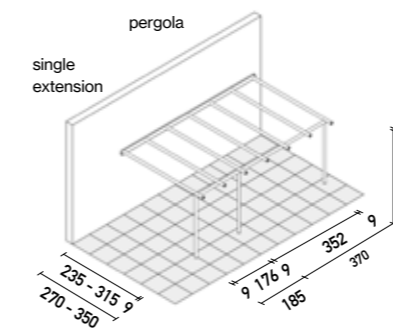

W 370 D 270 - 350

W 370 - Pergola / Pergola / Pergola / Pergola

D 270	PESADD43
D 350	PESADD44

Extension / Estensione / Extension / Erweiterung

W 185 - Extension / Estensione / Extension / Erweiterung

D 270	ESPESADD43
D 350	ESPESADD44

FREESTANDING PERGOLA / PERGOLA AUTOPORTANTE / PERGOLA AUTOPORTANTE / FREI STEHENDE PERGOLA

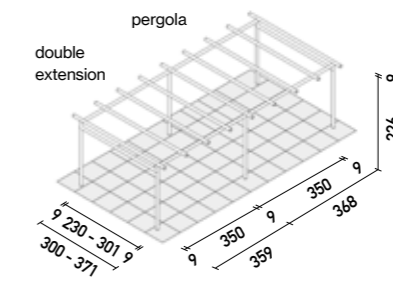
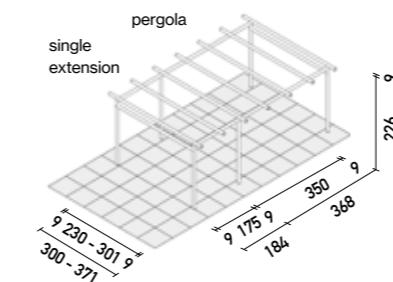

W 368 D 300 - 371

W 368 - Pergola / Pergola / Pergola / Pergola

D 300	PESAUT43
D 371	PESAUT44

Extension / Estensione / Extension / Erweiterung

W 184 - Single extension Estensione singola
Extension simple / Einfache Erweiterung

D 300	ESPESAUT43
D 371	ESPESAUT44

W 359 - Double extension / Estensione doppia
Extension double / Doppelte Erweiterung

D 300	EDPESAUT43
D 371	EDPESAUT44

The structure is in treated Nordic pine and can be painted in dark walnut, teak or in colours from the Unopiù Colour range. The structure can be enclosed using infill components the Nagi range. / La struttura è in pino nordico impregnato e può essere tinteggiata nelle tonalità noce scuro, teak o nei colori della linea Unopiù Color. / La struttura può essere chiusa con gli elementi del sistema Nagi. / La structure est en pin nordique traité et peut être teintée dans les tonalités noyer foncé, teck ou dans les couleurs de la ligne Unopiù Color. La structure peut être fermée avec les éléments de la ligne Nagi. / Die Struktur ist aus imprägniertem, nordischem Kiefernholz und kann mit den Farben dunkelbraun, teakholzfarben oder den Farben der Serie Unopiù Color angestrichen werden. Dazu passend gibt es die Elemente der Kollektion Nagi.

→ Treated Nordic lamellar pine / Legno lamellare di pino nordico impregnato / Bois lamellé en pin nordique traité
Imprägniertes Brettschneitholz aus Kiefer

Nagi

TRELLISES / GRIGLIATI / TREILLAGES / TRENNGITTER



Diamond pattern / Maglia romboidale / Maille losange / Rautenmuster

	75 X 115	GRCRI711
	75 X 148	GRCRI714
	148 x 115	GRCRI1411
	148 X 148	GRCRI1414
	220 X 115	GRCRI2111
	220 X 148	GRCRI2114

Square pattern / Maglia quadrata / Maille carrée / Quadratisches Muster

	75 X 115	GRQU711
	75 X 148	GRQU714
	148 x 115	GRQU1411
	148 X 148	GRQU1414
	220 X 115	GRQU2111
	220 X 148	GRQU2114

RECTANGULAR FLOWER POTS / PORTAVASI RETTANGOLARI / POTS DE FLEURS RECTANGULAIRES / BLUMENKÄSTEN

	Flower pots for square post / Portavasi per palo quadrato Pots de fleurs pour pilier carré / Blumenkästen für Vierkantpfosten	L 75 W 45 H 44	FRSH7545
planter	Flower pots for round post / Portavasi per palo rotondo Pots de fleurs pour pilier rond / Blumenkästen für runde Pfosten	L 75 W 45 H 44	FRSH7545R
	Flower pots extension for square post / Estensione portavasi per palo quadrato Extension pots de fleurs pour pilier carré / Erweiterung Blumenkästen für Vierkantpfosten	L 69 W 45 H 44	ESFRSH7545
extension	Flower pots extension for round post / Estensione portavasi per palo rotondo Extension pots de fleurs pour pilier rond / Erweiterung Blumenkästen für runde Pfosten	L 69 W 45 H 44	ESFRSH7545R

ROLL SHADE / TELO ROLL / TOILE ROLL / SONNENSCHUTZROLLO

Compatible with Nagi pergolas supplied complete with aluminium casing, ivory gloss finish, spring loaded roller and tracks / Compatible con la pergola Nagi viene fornito completo di coprirullo in alluminio smaltato di colore avorio, avvolgibile a molla e guide / Compatible avec la pergola Nagi fournie avec coffre rouleau en aluminium laqué ivoire, enrouleur à ressort et glissières
Kompatibel mit Nagi-Pergolen, komplett mit elfenbeinfarbener lackierter Blende aus Aluminium, Federzugmechanik und Schienen.

Adjustable shade 100% acrylic colour ecru Telo regolabile di acrilico 100% di colore ecru Toile réglable 100% acrylique couleur ecru Verstellbarer Sonnenschutz 100% Acryl ecru	W 372 D 400 (For pergola / Per pergola / Pour pergola / Für Pergola)	ROLLSH
	W 186 D 400 (For extension / Per estensione / Pour extension / Für Erweiterung)	ROLLSHE

For the white finish add the letter "W" in front of the article code e.g. WCOS45G

Per la finitura di colore bianco aggiungere la lettera "W" davanti al codice articolo es. WCOS45G

Pour la finition en blanc ajouter la lettre "W" devant le code de l'article, par exemple WCOS45G

Für die weiße Ausführung ergänzen Sie den Buchstaben "W" am Anfang der Artikelnummer, z.B. WCOS45G

→ Treated Nordic lamellar pine / Legno lamellare di pino nordico impregnato / Bois lamellé en pin nordique traité
Imprägniertes Brettschittholz aus Kiefer

WOOD SLAT ROOFING / COPERTURA IN LISTELLI DI LEGNO / COUVERTURE EN LAMBRIS DE LATTES DE BOIS BEDACHUNG MIT HOLZLEISTEN

Panels of treated nordic pine wood slats with optional LED lighting / Pannelli a listelli di pino nordico impregnato con illuminazione a LED opzionale / Panneaux en lambris de lattes de bois en pin nordique imprégné avec illumination LED en option / Paneele aus behandelten nordischen Kiefernholzleisten mit optionaler LED-Beleuchtung.

LED characteristics: 13200mAh – 2700k – 600lm / Caratteristiche LED: 13200mAh - 2700k - 600lm / Caractéristiques LED : 13200mAh - 2700k - 600lm
LED Merkmale: 13200mAh – 2700k – 600lm

Recharge: solar – USB / Ricarica: solare - USB / Recharge: solaire - USB / Ladung: Sonne - USB



Slat roofing / Copertura a listelli / Couverture en lambris de lattes de bois / Bedachung mit Holzleisten

For pergola / Per pergola / Pour pergola / Für Pergola PESADD43	COADSH43
For extension / Per estensione / Pour extension / Für Erweiterung ESPESADD43	COADSH43ES
For pergola / Per pergola / Pour pergola / Für Pergola PESADD44	COADSH44
For extension / Per estensione / Pour extension / Für Erweiterung ESPESADD44	COADSH44ES
For pergola / Per pergola / Pour pergola / Für Pergola PESAUT43	COAUSH43
For single extension / Per estensione singola / Pour extension simple / Für einfache Erweiterung ESPESAUT43	COAUSH43ES
For double extension / Per estensione doppia / Pour double extension / Für doppelte Erweiterung EDPEAUT43	COAUSH43ED
For pergola / Per pergola / Pour pergola / Für Pergola PESAUT44	COAUSH44
For single extension / Per estensione singola / Pour extension simple / Für einfache Erweiterung ESPESAUT44	COAUSH44ES
For double extension / Per estensione doppia / Pour double extension / Für doppelte Erweiterungen EDPEAUT44	COAUSH44ED

Slat roofing with LED / Copertura a listelli con LED / Couverture en lambris de lattes de bois avec LED / Bedachung mit Leisten und LED

For pergola / Per pergola / Pour pergola / Für Pergola PESADD43 (n. 4 Led)	COADSH43LED
For extension / Per estensione / Pour extension / Für Pergola ESPESADD43 (n.2 Led)	COADSH43ESLED
For pergola / per pergola / Pour pergola / Für Pergola PESADD44 (n. 4 Led)	COADSH44LED
For extension / Per estensione / Pour extension / Für Erweiterung ESPESADD44 (n.2 Led)	COADSH44ESLED
For pergola / per pergola / Pour pergola / Für Pergola PESAUT43 (n. 4 Led)	COAUSH43LED
For single extension / Per estensione singola / Pour extension simple / Für einfache Erweiterung ESPESAUT43 (n.2 Led)	COAUSH43ESLED
For double extension / Per estensione doppia / Pour double extension / Für doppelte Erweiterung EDPEAUT43 (n.4 Led)	COAUSH43EDLED
For pergola / Per pergola / Pour pergola / Für Pergola PESAUT44 (n. 4 Led)	COAUSH44LED
For single extension / Per estensione singola / Pour extension simple / Für einfache Erweiterung ESPESAUT44 (n.2 Led)	COAUSH44ESLED
For double extension / Per estensione doppia / Pour double extension / Für doppelte Erweiterung EDPEAUT44 (n.4 Led)	COAUSH44EDLED

→ Treated Nordic lamellar pine / Legno lamellare di pino nordico impregnato / Bois lamellé en pin nordique traité
Imprägniertes Brettschittholz aus Kiefer

Nagi - Wood Garden

Additional pillar for freestanding pergola Ø 88 H 245 / Pilastro aggiuntivo per pergola autoportante Ø 88 H 245 Pilier supplémentaire pour pergola autoportante Ø 88 H 245 / Zusätzlicher Pfosten für freistehende Pergola Ø 88 H 245	99PRO9245AGC
Adjustable bracket for fixing to ground / Staffa regolabile per fissaggio a terra Support réglable pour la fixation au sol / Verstellbarer Pfostenschuh für Bodenbefestigung	PIASAPR1
Half pillar H 215 wall fixing for trellises / Mezzo pilastro H 215 fissaggio a parete per tralicci Fixation murale demi-pilier H 215 pour trellis / Halber Pfosten H 215 als Wandbefestigung für Trenngitter	99PRO44215AGC
Additional pillar for attached pergola Ø 88 H 215 / Pilastro aggiuntivo per pergola addossata Ø 88 H 245 Pilier supplémentaire pour pergola adossée Ø 88 H 245 / Zusätzlicher Pfosten für Anbaupergola Ø 88 H 215	99PRO9215AGC
Additional beam for pergola PESADD43 Ø 88 H 232 / Trave supplementare per pergola PESADD43 Ø 88 H 232 Poutre supplémentaire pour pergola PESADD43 Ø 88 H 232 / Zusätzlicher Balken für Pergola PESADD43 Ø 88 H 232	99PRO9232AGC
Additional beam for pergola PESADD44 Ø 88 H 305 / Trave supplementare per pergola PESADD44 Ø 88 H 305 Poutre supplémentaire pour pergola PESADD44 Ø 88 H 305 / Additional beam for pergola PESADD44 Ø 88 H 305	99PRO9305AGC

BAMBOO SHADES / STUOIE DI CANNE DI BAMBÙ / NATTES EN CANNES DE BAMBOU / BAMBUSMATTEN

Shade kit made with bamboo canes of varying diameter (from 1 to 2 cm) connected by a stainless steel wire. Kits are supplied complete with fittings / Kit di stuoie realizzate con canne di bambù di sezione variabile (da cm 1 a cm 2 ca.) e unite da un filo passante di acciaio inox. I kit sono completi di fissaggi / Kit de nattes en cannes de bambou de section variant de 1 à 2 cm, reliées par un fil d'acier inoxydable, avec fixations. Kit Bambusmatten, gefertigt aus Bambusstäben mit unterschiedlichem Schnittdurchmesser (von 1 cm bis ca. 2 cm), mit Edelstahldraht verwoben, komplett mit Befestigungsmaterial.

Bamboo shades / Stuoie di canne di bambù / Nattes en cannes de bambou / Bambusmatten	W 185 D 250	BAMR
Compatible with the following pergola and extension codes / Abbinabili con i seguenti codici di pergole ed estensioni Peut être associée avec les codes suivants de pergolas et extensions / Passen zu folgenden Pergolen und Erweiterungen		
ESPESADD43 - ESPESADD44 - ESPESAUT43 - ESPESAUT44		COBAM3L
PESADD43 - PESAUT43 - EPESAUT43		COBAM4L
PESADD44 - PESAUT44 - ESPESAUT44		COBAM5L



WATERPROOF SHADE / TELO IMPERMEABILE / TOILE IMPERMÉABLE / WASSERFESTE PLANE

Waterproof shade (29% polyester coated with 71% PVC) white for freestanding pergola Nagi / Telo impermeabile (poliestere 29% spalmato di PVC 71%) di colore bianco per pergola autoportante Nagi / Toile imperméable (29% polyester - enduit 71% PVC), blanche pour pergola autoportante Nagi / Wasserfeste, weiße Plane für frei stehende Pergola Nagi (29% Polyesterbeschichtung mit 71% PVC)

For freestanding pergola Art. PESAUT44 / Per pergola autoportante Art. PESAUT44 / Pour pergola autoportante Ref. PESAUT44 Für freistehende Pergola Artikel Art. PESAUT44	TMSH44
With 1 extension / Con 1 estensione / Avec 1 extension / Mit einer Erweiterung	TMSH44E1
With 2 extension / Con 2 estensioni / Avec 2 extension / Mit zwei Erweiterungen	TMSH44E2

To order roofing for pergola with more than 2 extensions, substitute the "2" in the relative code for pergolas with 2 extensions with the number of those required (e.g. TSH44E3 - TMSH44E4)
Per ordinare coperture di pergole con più di 2 estensioni, sostituire il "2" nei codici relativi alle pergole con 2 estensioni con il numero di quelle previste (es. TMSH44E3 - TMSH44E4)
Pour commander les couvertures de pergolas ayant plus de 2 extensions, remplacer le "2" dans les codes de référence des pergolas à 2 extensions, avec le numéro des pergolas désirées (ex. TMSH44E3 - TMSH44E4) / Für Überdachungen für Pergolen mit mehr als 2 Erweiterungen ersetzen Sie die Nummer „2“ in der Artikelnummer mit der Anzahl der gewünschten Erweiterungen (z.B. TMSH44E3 - TMSH44E4).

SPECIAL BRACKETS / STAFFE SPECIALI / ÉQUERRES SPÉCIALES / SPEZIELLE WINKEL

	SL brackets: to fix any section to the ground, 10 Ø bolts and plugs are required / Staffe SL: per fissare a terra qualunque profilo, necessitano di bulloni Ø 10 e tasselli / Équerres SL : pour fixer au sol tous types de profilé : des boulons Ø 10 et des chevilles sont nécessaires. / Winkel SL: zur Befestigung von Profilhölzern am Boden. Zusätzlich werden Bolzen Ø 10 und Dübel verwendet. Winkel SLP: Universalwinkel verschieden einsetzbar.	width	height	length	thickness	
		60	40	190	5	SL
	SP30 screen brackets: to fix various panels to posts or walls. SRI-SBA: to fix posts to railings or balustrades / Staffe per schermature SP30N: per il fissaggio dei vari pannelli sia ai pilastri che a muro. SRI-SBA: per fissare i pilastri sia alla ringhiera che sulla balaustra / Équerres pour fermeture SP30, pour fixer différents panneaux aux piliers ou à la paroi. SRI - SBA, pour fixer les piliers à une rambarde ou balustrade. / Schraubprofile für Rankgitter: SP30-SP30M: um die verschiedenen Paneele an Pfosten bzw. an der Wand zu befestigen. SRI-SBA: um Pfosten am Geländer, bzw.an der Brüstung zu befestigen.	width	height	length	thickness	
		-	-	-	-	SP30N
		-	-	-	-	SBA
		-	-	-	-	SRI

→ Treated Nordic lamellar pine / Legno lamellare di pino nordico impregnato / Bois lamellé en pin nordique traité
Imprägniertes Brettschнитtholz aus Kiefer

	Nerved brackets in galvanized iron to fix 90 x 90 posts raised from the ground, complete with hardware. Plugs for fixing to the ground excluded. To be used only with attached structures / Staffa nervata rialzata in ferro zincato per il fissaggio sollevato da terra di pilastri 90 x 90 completa di ferramenta. Tasselli per l'ancoraggio a terra esclusi. Da utilizzare esclusivamente su strutture addossate / Equerre nervurée réhaussée en fer galvanisé pour fixation surélevée des piliers du sol 90 x 90, visserie incluse. Chevilles pour fixation au sol exclues. Utiliser uniquement pour structure adossée. / Balkenschuhe aus verzinktem Eisen zur erhöhten Befestigung von Pfosten 90 x 90 am Boden, komplett mit Eisenwaren, jedoch ohne Dübel zur Befestigung am Boden. Sie sind für die Anbaustrukturen zu gebrauchen	width	height	length	thickness	
		100	160	80	5	SRU99C

	Double raised brackets in galvanized iron to fix 90 x 90 and 70 x 70 posts raised from the ground. The brackets are complete with hardware Plugs to fix to ground are excluded / Staffe rialzate doppie in ferro zincato per il fissaggio sollevato da terra di pilastri 90 x 90 e 70 x 70. Le staffe sono complete di ferramenta. Tasselli per l'ancoraggio a terra esclusi / Equerre réhaussée doubles en fer galvanisé pour fixation surélevée des piliers du sol 90 x 90 et 70 x 70. Les équerres sont livrées avec visserie. Chevilles pour fixation au sol exclues. / Doppelte Balkenschuhe aus verzinktem Eisen zur erhöhten Befestigung von Pfosten 90 x 90 und 70 x 70 am Boden, komplett mit Eisenwaren, doch ohne Dübel zur Befestigung am Boden.	width	height	length	thickness	
		195	190	90	3	SRCD99C
		175	190	70	3	SRCD77C

	Clamps used to fix 90 x 90 (SINT) posts to the ground. Ref. SINT1 is used to fix square corner posts where structures are to be closed laterally / Zanche per fissare a terreno pilastri 90 x 90 (SINT). L'art. SINT1 si utilizza per il fissaggio a terra dei pilastri quadrati d'angolo in strutture da chiudere lateralmente / Support pour fixer au sol des piliers 90 x 90 (SINT). Le support Réf. SINT1 est utilisé pour la fixation au sol de piliers d'angle à section carrée dans les structures à fermer latéralement. / Um quadratische Pfosten 90 x 90 (SINT) am Boden zu befestigen. Pfostenanker SINT1: für die quadratischen Eckpfosten Systeme, die seitlich mit Paneelen geschlossen werden.	width	height	length	thickness	
		102	606	60	6	SINT
		102	606	60	6	SINT1
		102	606	60	6	SINTR

LAMINAR SECTIONS / PROFILI LAMELLARI / PROFILÉS LAMELLÉS / LEIMHOLZPFOSTEN / MASSIVHOLZPFOSTEN

	Available in 2100, 2200,2500 and 4000 mm, lengths and used as load bearing posts in almost all Unopiù structures ensuring optimum mechanical performance / Disponibili di lunghezza mm 2100, 2200,2500 e 4000, sono utilizzati come pilastri portanti in quasi tutte le strutture Unopiù e permettono di ottenere soluzioni meccaniche più spinte / Disponibles en 2100, 2200, 2500 et 4000 mm de longueur, ils sont utilisés comme piliers portants pour presque toutes les structures Unopiù et permettent de réaliser des solutions mécaniques plus solides. In den Längen von 2100, 2200, 2500 und 4000 erhältlich werden diese Leimholzpfosten als tragende Pfosten in fast allen Unopiù Konstruktionen benutzt, um so stabilere, mechanische Ergebnisse zu erzielen.	section	length	
		90 x 90	2200	PL9922V
		90 x 90	2500	PL9925VC
		90 x 90	4000	PL994VC
		Ø68	2100	PR682SH

	Available in various lengths and used as struts, in pairs, and as load bearing beams on structures with maximum spans of 4-5 m / Disponibili in diverse lunghezze si utilizzano come arcarecci e, in coppia, anche come travi portanti su strutture con luci massime di m 4 - 5. / Disponibles en plusieurs longueurs, ils sont utilisés comme chevrons et, accouplés, également comme poutres portantes sur des structures maximum de 4 - 5 m. / Sie sind in verschiedenen Längen erhältlich und werden als Balken oder paarweise als Tragpfosten für Systeme mit 4 bis 5 m Spannweite genutzt.	section	length	
		60 x 150	4490	L615449VC
		60 x 150	5990	L6156VC

	Available in various lengths and used with screens, for fixing panels or in the construction of light structures. / Disponibili di lunghezza mm 2700 e 5490, si usano come travi portanti su strutture con luci molto ampie, per evitare l'inserimento di pilastri intermedi. / Disponibles en 2700 et 5490 mm de longueur, ils s'utilisent comme poutres portantes dans des structures à grandes ouvertures pour éviter d'utiliser des piliers intermédiaires. / In den Längen von 2700 oder 5490 werden sie als Balken für die sehr großen Spannweiten der Systeme ohne Mittelpfosten genutzt.	section	length	
		90 x 150	2700	L915270VC
		90 x 150	5490	L9155VC

	Curved sections describing a quarter circle with a 2.40 m outer radius and used to create and personalize a wide range of applications. / Profili curvilinei pari ad un quarto di cerchio con raggio esterno di m 2,40, possono essere utilizzati per realizzare e personalizzare molte soluzioni. / Profilés courbés formant un quart de cercle avec rayon extérieur de 2,40 m, ils peuvent être utilisés pour réaliser et personnaliser de nombreuses solutions. / Die gebogenen Brettschnitthölzer entsprechen maßgenau dem Viertel eines Kreisbogens und haben einen Außenradius von 2,40. Sie können zur persönlichen Gestaltung verschiedener Konstruktionen verwendet werden.	section	length	
		90 x 90	2700	ARCOVC

→ Treated Nordic lamellar pine / Legno lamellare di pino nordico impregnato / Bois lamellé en pin nordique traité
Imprägniertes Brettschнитtholz aus Kiefer

Wood Garden

SOLID POSTS / PILASTRI DI MASSELLO / PILIERS EN BOIS MASSIF / MASSIVHOLZPFOSTEN



Available in various lengths and used as struts, in pairs, and as load bearing beams on very light structures / Disponibili in diverse lunghezze sono utilizzati nelle schermature, per il fissaggio dei pannelli, o per ottenere strutture molto leggere / Disponibles en plusieurs longueurs, ils sont utilisés pour les clôtures, pour fixer les panneaux ou pour réaliser des structures très légères. Die Pfosten aus Massivholz sind in verschiedenen Längen erhältlich und werden beim Aufbau der Sichtschutzwände, zur Befestigung der Paneele und für sehr leichte Konstruktionen verwendet.

section	length	
70 x 70	2090	P7721V
70 x 70	1250	P7712FV



They are available in 3150, 3490, and 3830 mm lengths and can be used in max. 2,5 - 3 m spans. For longer spans they can be used in pairs and secured with relative hardware. Disponibili di lunghezza mm 3150, 3490 e 3830, si usano su luci massime di m 2,5 - 3. Per luci più ampie possono essere adoperate in coppia, per mezzo della relativa ferramenta. Disponibles en 3150, 3490 et 3830 mm, elles sont utilisées sur des ouvertures de 250 - 300 cm max. Pour des ouvertures plus grandes, les poutres peuvent s'utiliser accouplées, à l'aide des ferrures. / Die Balken sind in den Längen von 3150, 3490, und 3830 erhältlich und für Spannweiten bis zu 2,5 - 3 m geeignet. Für größere Spannweiten können zwei Balken mit den entsprechenden Metallteilen miteinander verbunden werden.

section	length	
45 x 117	3150	T4511315VC
45 x 117	3490	T4511349VC
45 x 117	3830	T4511383VC

SECTIONS / PROFILI / PROFILÉS / PROFILE



Special profiles used as either edging or trellis components, can also be used in many other applications. / Profili speciali utilizzati come doghe di rifinitura alcuni e come componenti dei grigliati gli altri, possono realizzare e rifinire anche molte altre soluzioni. / Profilés spéciaux utilisés en lattes de finition et en éléments de treillages, ils peuvent être utilisés également dans de nombreuses autres situations, pour réaliser et compléter de nombreuses solutions. Die Brettschnitthölzer werden als Zierleisten oder als Elemente der Rankgitter benutzt, bieten aber auch viele andere Gestaltungsmöglichkeiten.

section	length	
45 x 55	2090	PROUVC
22 x 95	1250	PAVDOG3VC

TRELLISES / GRIGLIATI / TREILLAGES / RANKGITTER

Diamond pattern / Maglia romboidale / Maille losange / Rautenmuster



53 x 115,5	R12NC
53 x 148,5	R13NC
53 x 177	R14NC
115,5 x 115,5	R22NC
115,5 x 148,5	R23NC
115,5 x 177	R24NC
148,5 x 148,5	R33NC
148,5 x 177	R34NC
177 x 177	R44NC

→ Treated Nordic lamellar pine / Legno lamellare di pino nordico impregnato / Bois lamellé en pin nordique traité
Imprägniertes Brettschnittholz aus Kiefer

Square pattern / Maglia quadrata / Maille carrée / Quadratisches Muster



53 x 115,5	GR12NC
53 x 148,5	GR13NC
53 x 177	GR14NC
115,5 x 115,5	GR22NC
115,5 x 148,5	GR23NC
115,5 x 177	GR24NC
148,5 x 148,5	GR33NC
148,5 x 177	GR34NC
177 x 177	GR44NC

Shade panels / Frangisole / Panneaux brise-soleil / Sonnenschutzpaneele



53 x 115,5	PFS12NC
53 x 148,5	PFS13NC
53 x 177	PFS14NC
115,5 x 115,5	PFS22NC
115,5 x 148,5	PFS23NC
115,5 x 177	PFS24NC
148,5 x 115,5	PFS32NC
148,5 x 148,5	PFS33NC
148,5 x 177	PFS34NC
177 x 115,5	PFS42NC
177 x 148,5	PFS43NC
177 x 177	PFS44NC

→ Treated Nordic lamellar pine / Legno lamellare di pino nordico impregnato / Bois lamellé en pin nordique traité
Imprägniertes Brettschnittholz aus Kiefer



Wood Garden

FLOWER POTS / PORTAVASI / POTS DE FLEURS / PLFANZKÄSTEN

Square flower pots / Portavasi quadrati / Pots de fleurs carrées / Quadratische Pflanzkästen

	53x53x44	FQ55NC
	60x60x44	FQ60NC

Rectangular flower pots / Portavasi rettangolari / Pots de fleurs rectangulaires / Rechteckige Pflanzkästen

	115,5x40x44	FR11540NC
	115,5x50x44	FR11550NC
	148,5x40x44	FR14840NC
	148,5x50x44	FR14850NC
	177x40x44	FR17740NC
	177x50x44	FR17750NC

SCREWS - PLUGS / VITI - TASSELLI / VIS - CHEVILLES / SCHRAUBEN - DÜBEL



Screws: galvanized and tropicalized, like all hardware, available in 3 sizes / Viti: tropicalizzate zincate, come il resto della ferramenta, sono disponibili in tre misure / Vis : tropicalisées et galvanisées comme toutes nos ferrures, trois mesures disponibles. / Schrauben: verzinkt und tropentauglich, wie alle Beschläge, verfügbar in 3 Größen

Ø	W	
6	100	V610
6	110	V611
6	130	V613



Plugs TE: plugs: 10 Ø, to fix wood to brickwork or concrete. TF plugs: Ø 16 in steel, to fix any bracket to brick or concrete / Tasselli ad espansione. Tasselli TE: Ø 10, per fissare il legno a muratura e a cemento. Tasselli TF: elementi in acciaio Ø 16, per fissare a mattone pieno o cemento ogni staffa / Chevilles à expansion. Chevilles TE : Ø 10 pour fixer les éléments en bois à la maçonnerie et au ciment. Chevilles TF : éléments en acier Ø 16 pour fixer les équerres sur de la brique pleine ou du ciment. / Spreizdübel TE: Ø 10 mm, um Holzelemente an Mauer- oder Betonbauten zu befestigen. Dübel TF: Stahlelemente Ø 16 mm, um Beschläge auf Vollstein oder Beton zu befestigen.

Ø	W	
10	160	TE
16	80	TF



Chemical plugs: special plugs which can bond with any material (hollow bricks, tufa, etc). Supplied in packs of 6 with installation accessories / Tasselli chimici, speciali elementi che hanno la possibilità di far presa su qualsiasi tipo di materiale (forati, tufo, ecc.). Vengono forniti in confezioni da 6 pz., con gli accessori per l'installazione. Chevilles chimiques: pièces spéciales qui permettent de faire prise sur n'importe quel type de matériau (briques creuses, tuf, etc.), fournies en lots de 6 pièces avec accessoires pour la mise en place. / Chemische Spezialdübel. Spezialelemente, die in jedem Material haften (Loch-, Tuffstein usw.). Die Lieferung erfolgt in einer Sechserpackung, mit Zubehör zur Installation.

Ø	W	
16	110	TC6SP

→ Treated Nordic lamellar pine / Legno lamellare di pino nordico impregnato / Bois lamellé en pin nordique traité
Imprägniertes Brettschneittholz aus Kiefer

ACCESSORIES FOR TRELLISES / ACCESSORI PER GRIGLIATI / ACCESSOIRES POUR TREILLAGES / ZUBEHÖR FÜR RANKGITTER



Crowning beam / Trave di coronamento / Poutre de couronnement / Abschlussleiste

W 4.5 x 9.5 x 400 T459539VC



Sphere / Sfera / Sphère / Kugel

Ø 7 SFE70V



Post for side support of various panels / Pilastro per il sostegno laterale dei vari pannelli
Pilier pour le soutien lateral des différents panneaux / Seitenpfosten zur Befestigung unterschiedlicher Paneele

H 210 P7721VC



Post for side support of various panels / Pilastro per il sostegno laterale dei vari pannelli
Pilier pour le soutien lateral des différents panneaux / Seitenpfosten zur Befestigung unterschiedlicher Paneele

H 125 P7712FV



Wooden dowel for fixing balustrade / Tassello in legno per fissaggio a balaustra
Ancre en bois pour fixage à balustrade / Distanzstück zur Befestigung am Mauerwerk

L 7 P 4 H 7 BDF4



Bracket to fix panel / Staffa fissaggio pannelli / Équerre de fixation panneaux / Schraubprofil für Paneele

SP30N

FINISHES / FINITURE / FINITIONS / AUSFÜHRUNGEN



Nordic pine painted in bankirai Colour
Pino nordico verniciato bankirai
Pin nordique peint en couleur bankirai
Nordische Kiefer bankirairfarben



Nordic pine painted in white colour
Pino nordico verniciato bianco
Pin nordique peint en couleur blanc
Nordische Kiefer weiß



Painted wooden slats
Listelli di legno verniciati
Lattes de bois vernis
Lackierte Holzleisten



Bamboo mat
Stuoia bambù
Natte de bambou
Bambusmatte



100% acrylic fabric in ecru
Tessuto acrilico 100% ecru
Tissu 100% acrylique écru
Ecrufarbener Stoff aus 100% Acryl



Waterproof fabric in 29% polyester coated with 71% PVC white
Telo impermeabile poliestere 29% PVC 71 %
Tissu imperméable 29% polyester enduit 71% PVC blanc
Wasserfeste, weiße Plane (29% Polyesterbeschichtung mit 71% PVC)

→ Treated Nordic lamellar pine / Legno lamellare di pino nordico impregnato / Bois lamellé en pin nordique traité
Imprägniertes Brettschneittholz aus Kiefer

Orangerie

FREESTANDING GREENHOUSE / SERRA AUTOPORTANTE / SERRE AUTOPORTANTE / FREI STEHENDES GEWÄCHSHAUS

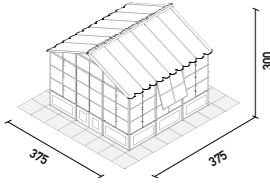

W 375 D 375 H 300

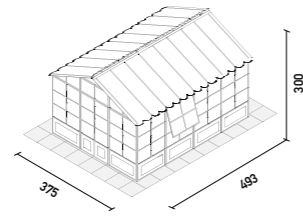

W 375 D 493 H 300

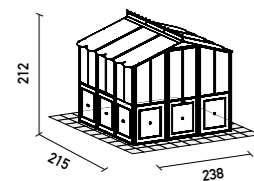

W 238 D 215 H 212

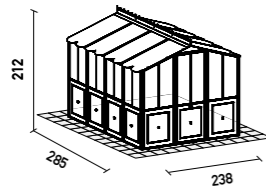

W 238 D 285 H 212

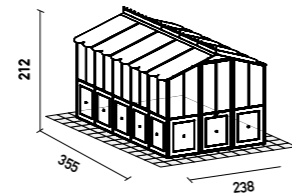

W 238 D 355 H 212

Greenhouse with polycarbonate roofing, 1 window and 1 door with polycarbonate side panelling
Serra con copertura di polycarbonato, 1 finestra e 1 porta con pannellatura laterale di polycarbonato
Serre avec couverture en polycarbonate gaufré, 1 fenêtre et 1 porte avec panneaux latéraux en polycarbonate / Gewächshaus mit Dach aus Polycarbonat, 1 Fenster, 1 Türe und Seitenverkleidung aus Polycarbonatplatten.

W 375 D 375 H 300 SAU33P

W 375 D 493 H 300 SAU34P

Greenhouse with 1 window and 1 door
Serra completa di 1 finestra e 1 porta
Serre complète avec 1 fenêtre et 1 porte
Gewächshaus mit 1 Fenster und 1 Tür

W 238 D 215 H 212 SAU215

W 238 D 285 H 212 SAU285

W 238 D 355 H 212 SAU355

Windows - Doors / Finestre - Porte / Fenêtres - Portes / Fenster - Türen

Supplement for additional window panel with polycarbonate panel (for SAU33P, SAU34P, SAD32P, SAD42P)
Supplemento per ulteriore pannello finestra con lastre di polycarbonato (per SAU33P, SAU34P, SAD32P, SAD42P)
Supplément pour panneau fenêtre supplémentaire avec plaques en polycarbonate (SAU33P, SAU34P, SAD32P, SAD42P)
Zusätzliches Fensterpaneel aus Polycarbonat (für SAU33P, SAU34P, SAD32P, SAD42P)

SPFSOR

Supplement for additional door panel with polycarbonate panel (for SAU33P, SAU34P, SAD32P, SAD42P)
Supplemento per ulteriore pannello porta con lastre di polycarbonato (per SAU33P, SAU34P, SAD32P, SAD42P)
Supplément pour panneau porte supplémentaire avec plaques en polycarbonate (SAU33P, SAU34P, SAD32P, SAD42P)
Zusätzliches Türpaneel aus Polycarbonat (für SAU33P, SAU34P, SAD32P, SAD42P)

SPPSOR

Supplement for additional window panel (for SAU215, SAU285, SAU355 SADSX215, SADDX215, SADSX285, SADDX285, SADSX355, SADDX355)
Supplemento per ulteriore pannello finestra (per SAU215, SAU285, SAU355 SADSX215, SADDX215, SADSX285, SADDX285, SADSX355, SADDX355)
Supplément pour panneau fenêtre supplémentaire (SAU215, SAU285, SAU355, SADSX215, SADDX215, SADSX285, SADDX285, SADSX355, SADDX355)
Zusätzliches Fensterpaneel (für SAU215, SAU285, SAU355 SADSX215, SADDX215, SADSX285, SADDX285, SADSX355, SADDX355)

SUPFINSER

WALL-MOUNTED GREENHOUSE / SERRA ADDOSSATA / SERRE ADOSSÉE / WANDMONTIERTES GEWÄCHSHAUS

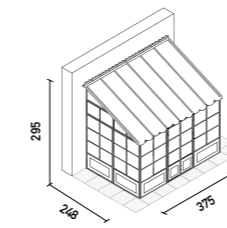

W 375 D 248 H 295

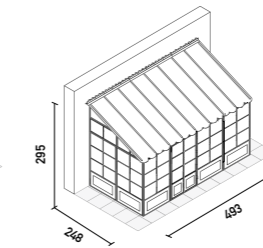

W 493 D 248 H 295

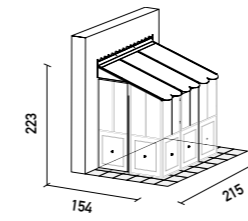

W 215 D 154 H 223

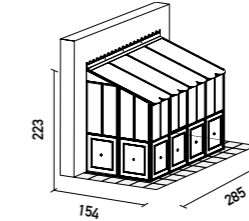

W 285 D 154 H 223

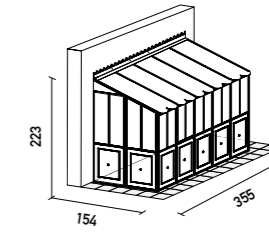

W 355 D 154 H 223

Greenhouse with polycarbonate roofing, 1 window and 1 door with polycarbonate side panelling
Serra con copertura di polycarbonato, 1 finestra e 1 porta con pannellatura laterale di polycarbonato
Serre avec couverture en polycarbonate, 1 fenêtre et 1 porte avec panneaux latéraux en polycarbonate
Gewächshaus mit Dach aus Polycarbonat, 1 Fenster, 1 Tür und Seitenverkleidung aus Polycarbonatplatten

W 375 D 248 H 295 SAD32P

W 493 D 248 H 295 SAD42P

Greenhouse with 1 window and 1 door left opening
Serra completa di 1 finestra e 1 porta apertura a sinistra
Serre complète avec 1 fenêtre et 1 porte ouverture à gauche
Gewächshaus mit 1 Fenster und 1 Tür (Öffnung nach links)

W 215 D 154 H 223 SADSX215

W 285 D 154 H 223 SADSX285

W 355 D 154 H 223 SADSX355

Greenhouse with 1 window and 1 door right opening
Serra completa di 1 finestra e 1 porta apertura a destra
Serre complète avec 1 fenêtre et 1 porte ouverture à droite
Gewächshaus mit 1 Fenster und 1 Tür (Öffnung nach rechts)

W 215 D 154 H 223 SADDX215

W 285 D 154 H 223 SADDX285

W 355 D 154 H 223 SADDX355

FINISHES / FINITURE / FINITIONS / AUSFÜHRUNGEN

Iron graphite
Ferro color grafite
Fer couleur graphite
Eisen grafitgrau

Polycarbonate embossed
Polycarbonato goffrato
Polycarbonate gaufré
Polycarbonat geprägt

→ Iron graphite / Ferro color grafite / Fer couleur graphite / Eisen grafitgrau
→ Polycarbonate embossed / Polycarbonato goffrato / Polycarbonate gaufré / Polycarbonat geprägt

→ Iron graphite / Ferro color grafite / Fer couleur graphite / Eisen grafitgrau
→ Polycarbonate embossed / Polycarbonato goffrato / Polycarbonate gaufré / Polycarbonat geprägt

Salento

UMBRELLAS / OMBRELLONI / PARASOLS / SONNENSCHIRME

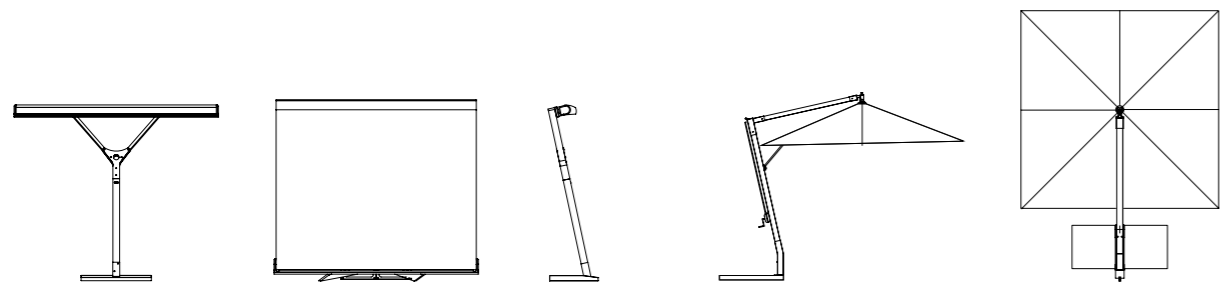

W 300 D 250 H 243

W 285 D 285 H 328

Umbrella in white steel and iroko wood with off white fabric, manual opening
 Ombrellone in acciaio bianco e legno di iroko con telo bianco grezzo, apertura manuale
 Parasol en acier galvanisé et thermolaqué blanc et bois d'iroko avec toile blanc écru, ouverture manuelle
 Sonnenschirm aus weißem Stahl und Irokoholz, mit weißem Schirm. Manuelles Öffnen

OSAMAB

Umbrella in bronze steel and iroko wood with cord fabric, manual opening
 Ombrellone in acciaio bronzo e legno di iroko con telo corda, apertura manuale
 Parasol en acier thermolaqué bronze et bois d'iroko avec toile corde avec toile blanche écru, ouverture manuelle
 Sonnenschirm aus bronzefarbenem Stahl und Irokoholz, mit ecrufarbenem Schirm. Manuelles Öffnen

OSAMABR

Umbrella in white steel and iroko wood with off white fabric, motorized opening
 Ombrellone in acciaio bianco e legno di iroko con telo bianco grezzo, apertura motorizzata
 Parasol en acier thermolaqué blanc et bois d'iroko avec toile blanc écru, ouverture motorisée
 Sonnenschirm aus weißem Stahl und Irokoholz, mit weißem Schirm. Motorbetriebenes Öffnen

OSAMOB

Umbrella in bronze steel and iroko wood with cord fabric, motorized opening
 Ombrellone in acciaio bronzo e legno di iroko con telo corda, apertura motorizzata
 Parasol en acier thermolaqué bronze et bois d'iroko avec toile corde, ouverture motorisée
 Sonnenschirm aus bronzefarbenem Stahl und Irokoholz, mit ecrufarbenem Schirm. Motorbetriebenes Öffnen

OSAMOBR

Umbrella square 285 x 285 H 328, side structure aluminium in white with off white fabric
 Ombrellone quadrato 285 x 285 H 328, struttura laterale alluminio bianco con telo bianco grezzo
 Parasol carré 285 x 285 H 328, structure latérale aluminium blanc avec toile blanc écru
 Quadratischer Schirm 285 x 285 H 328, Aluminiumgestell in der Farbe weiß, Bespannung naturweiß

OMABALB

Umbrella square 285 x 285 H 328, side structure aluminium in graphite with off white fabric
 Ombrellone quadrato 285 x 285 H 328, struttura laterale alluminio grafite con telo bianco grezzo
 Parasol carré 285 x 285 H 328, structure latérale aluminium graphite avec toile blanc écru
 Quadratischer Schirm 285 x 285 H 328, Aluminiumgestell in der Farbe grafitgrau, Bespannung naturweiß



OMABALG

Umbrella square 285 x 285 H 328, side structure aluminium wood effect with off white fabric
 Ombrellone quadrato 285 x 285 H 328, struttura laterale effetto legno con telo bianco grezzo
 Parasol carré 285 x 285 H 328, structure latérale aluminium effet bois avec toile blanc écru
 Quadratischer Schirm 285 x 285 H 328, Aluminiumgestell mit Holzeffekt lackiert

OMABALL

- Galvanized steel / Acciaio zincato / Acier thermolaqué / Verzinktes Stahl
- Lamellar iroko, wood / Legno lamellare di iroko / Bois d'iroko / Iroko-Leimholz
- Aluminum / Alluminio / Aluminium / Aluminium
- 100% acrylic fabric / Tessuto acrilico 100% bianco / 100% acrylique blanc / 100% Acryl

ACCESSORIES / ACCESSORI / ACCESSOIRES / ZUBEHÖR

	Set of 10 concrete blocks (for OSAMAB, OSAMABR OSAMOB, OSAMOBR) Set di 10 blocchi di cemento (per OSAMAB, OSAMABR, OSAMOB, OSAMOBR) Set de 10 dalles en ciment (pour OSAMAB, OSAMABR, OSAMOB, OSAMOBR) Set mit 10 Betonsplittplatten (für OSAMAB, OSAMABR OSAMOB, OSAMOBR)	OSABC
	Set of 6 tiles 50 x 50 in pebble concrete (for OMABALB, OMABALG, OMABALL) Set di 6 mattonelle 50 x 50 di cemento granigliato (per OMABALB, OMABALG, OMABALL) Set de 6 dalles de ciment granulé 50 x 50 (pour OMABALB, OMABALG, OMABALL) Set mit 6 Betonsplittplatten 50x50 cm (für OMABALB, OMABALG, OMABALL)	BAOMCAL
	Taupe coloured square umbrella, shade cover Copertura per telo ombrellone quadrato colore Taupe Housse pour toile parasol carré couleur Taupe Schutzhülle für quadratischen Sonnenschirm, taubengrau	COOMABALL

FINISHES / FINITURE / FINITIONS / AUSFÜHRUNGEN

	Aluminum graphite Alluminio grafite Aluminium graphite Aluminium grafitgrau		Aluminum wood effect Alluminio effetto legno Aluminium effet bois Aluminium in Holzoptik		Aluminum white Alluminio bianco Aluminium blanc Aluminium weiß
	Galvanized steel white gloss Acciaio zincato bianco lucido Acier thermolaqué blanc verni Verzinktes Stahl, glänzend weiß		Galvanized steel matt bronze Acciaio zincato bronzo Acier thermolaqué bronze Verzinktes Stahl, matt bronze		Lamellar iroko wood Legno lamellare iroko Bois d'iroko Iroko-Leimholz
	100% acrylic fabric in off white Tessuto acrilico 100% bianco grezzo Tissu 100% acrylique blanc écru Weißer Stoff aus 100% Acryl		100% acrylic fabric in cord Tessuto acrilico 100% corda Tissu 100% acrylique corde Ecrufarbener Stoff aus 100% Acryl		

- Galvanized steel / Acciaio zincato / Acier thermolaqué / Verzinktes Stahl
- Lamellar iroko, wood / Legno lamellare di iroko / Bois d'iroko / Iroko-Leimholz
- Aluminum / Alluminio / Aluminium / Aluminium
- 100% acrylic fabric / Tessuto acrilico 100% bianco / 100% acrylique blanc / 100% Acryl

Shibuya

WALL-MOUNTED PERGOLA / PERGOLA ADDOSSATA / PERGOLA ADOSSÉE / ANBAUPERGOLA

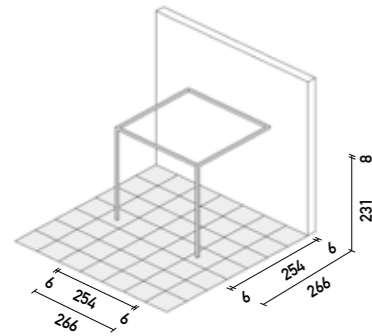

W 266 D 266

Wall-mounted pergola / Pergola addossata / Pergola adossée / Anbaupergola

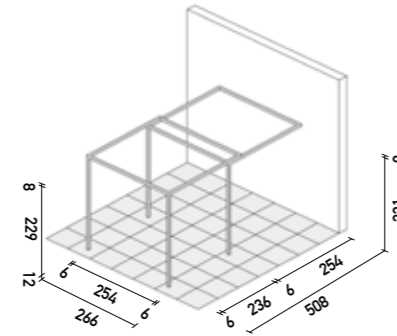

Extension / Estensione / Extension / Erweiterung

white / bianco / blanc / weiß SHI33ALADB

graphite / grafite / graphite / grafitgrau SHI33ALADG

FREESTANDING PERGOLA / PERGOLA AUTOPORTANTE / PERGOLA AUTOPORTANTE / FREI STEHENDE PERGOLA

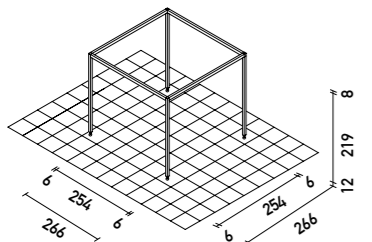

W 266 D 266

Freestanding pergola / Pergola autoportante / Pergola autoportante / Frei stehende Pergola

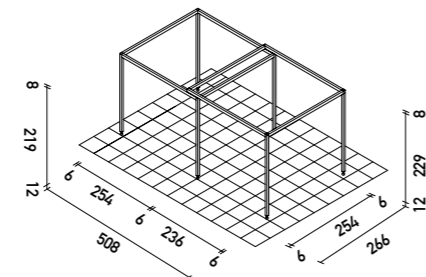

Extension / Estensione / Extension / Erweiterung

white / bianco / blanc / weiß SHI33ALB

graphite / grafite / graphite / grafitgrau SHI33ALG

EXTENSION / ESTENSIONE / EXTENSION / ERWEITERUNG / ERWEITERUNG

Extension for freestanding and attached pergola W 272.5 D 266

Estensione per pergola addossata e autoportante L 272.5 P 266

Extension pour pergola adossée et autoportante L 272.5 P 266

Erweiterung für frei stehende und Anbaupergola Breite 272.5 Tiefe 266

Fixing kit excluded / Kit di fissaggio escluso / kit de fixation exclu / Ohne Befestigungsmaterial

white / bianco / blanc / weiß SHI33ALESTB

graphite / grafite / graphite / graphit SHI33ALESTG

→ Aluminium powder coated / Alluminio verniciato a polveri / Aluminium galvanisé et thermolaqué / Aluminium pulverbeschichtet

MICROPERFORATED SHADE / TELO MICROFORATO / TOILE MICRO-PERFORÉE / MIKROPERFORIERTES TUCH

Structure colour / Colore struttura / Couleur structure / Gestellfarbe standard / base / base / basic extendable / estensibile / extensible / Erweiterung

White / Bianco / Blanc / Weiß SHICM3QAB SHICM3QABE

Graphite / Grafite / Graphite / Grafitgrau SHICM3QAG SHICM3QAGE

BAMBOO SHADE / STUOIE DI BAMBÙ / CANNES DE BAMBOU / BAMBUSMATTEN

Structure colour / Colore struttura / Couleur structure / Gestellfarbe standard / base / base / basic extendable / estensibile / extensible / Erweiterung

White / Bianco / Blanc / Weiß SHICB3QAB SHICB3QABE

Graphite / Grafite / Graphite / Grafitgrau SHICB3QAG SHICB3QAGE

WOODEN SLATS (PAINTED) / LISTELLI DI LEGNO (VERNICIATI) / LATTES DE BOIS (TRAITÉES) / BEHANDELTE HOLZLEISTEN (LACKIERT)

Structure colour / Colore struttura / Couleur structure / Gestellfarbe standard / base / base / basic extendable / estensibile / extensible / Erweiterung

White / Bianco / Blanc / Weiß SHICL3QAB SHICL3QABE

Graphite / Grafite / Graphite / Grafitgrau SHICL3QAG SHICL3QAGE

SIDE BLINDS / TENDE PERIMETRALI / STORES LATÉRAUX / SEITENROLLOS

Blind W 254 for white pergola

Tenda L 254 per la pergola di colore bianco

Store L 254 pour pergola couleur blanc

Rollo B 254 für weiße Pergola

SHITE3QB

Blind W 254 for pergola in graphite

Tenda L 254 per pergola di colore grafite

Store L 254 pour pergola couleur graphite

Rollo B 254 für grafitgraue Pergola

SHITE3QG

→ Aluminium powder coated / Alluminio verniciato a polveri / Aluminium galvanisé et thermolaqué / Aluminium pulverbeschichtet

Shibuya

ACCESSORIES / ACCESSORI / ACCESSOIRES / ACCESSOIRES / ZUBEHÖR

<p>Pair of brackets for fixing/blocking post-parapet/wall for fixed and mobile pergolas, white Coppia di staffe fissaggio/stazionamento pilastro-parapetto/muro per pergola fissa/mobile bianca Paire d'équerres pour fixation/stationnement pilier-parapet pour pergola fixe et mobile blanche 1 Paar Halterungen zur Befestigung / Fixierung von Pfosten an der Wand oder Brüstung, für festmontierte oder mobile Pergolen, Farbe weiß.</p>	STAPSHI2B
<p>Pair of brackets for fixing/blocking post-parapet/wall for fixed and mobile pergolas, graphite Coppia di staffe fissaggio/stazionamento pilastro-parapetto/muro per pergola fissa/mobile grafite Paire d'équerres pour fixation/stationnement pilier-parapet pour pergola fixe et mobile couleur graphite 1 Paar Halterungen zur Befestigung / Fixierung von Pfosten an der Wand oder Brüstung, für festmontierte oder mobile Pergolen, Farbe grafitgrau</p>	STAPSHI2G
<p>Pair of brackets for fixing/blocking post-railing for fixed and mobile pergolas, white Coppia di staffe fissaggio/stazionamento pilastro-ringhiera per pergola fissa/mobile bianca Paire d'équerres pour fixation/stationnement pilier-balustrade pour pergola fixe et mobile blanche 1 Paar Halterungen zur Befestigung / Fixierung von Pfosten am Geländer, für festmontierte oder mobile Pergolen, Farbe weiß.</p>	STARSHI2B
<p>Pair of brackets for fixing/blocking post-railing for fixed and mobile pergolas, graphite Coppia di staffe fissaggio/stazionamento pilastro-ringhiera per pergola fissa/mobile grafite Paire d'équerres pour fixation/stationnement pilier-balustrade pour pergola fixe et mobile couleur graphite 1 Paar Halterungen zur Befestigung / Fixierung von Pfosten am Geländer, für festmontierte oder mobile Pergolen, Farbe grafitgrau</p>	STARSHI2G
<p>Bracket removable to fix the mobile pergola to the ground (2 brackets are required per pergola), white Staffa removibile per posizionamento a terra pergola mobile (necessarie n. 2 staffe per pergola) bianca Équerre enlevable pour positionner la pergola mobile au sol (utiliser 2 équerres par pergola) blanche Bewegliches Profil zur Befestigung von Pfosten am Boden für bewegliche Pergola (für jede Pergola 2 Profile), Farbe weiß</p>	STATSHIB
<p>Bracket removable to fix the mobile pergola to the ground (2 brackets are required per pergola), graphite Staffa removibile per posizionamento a terra pergola mobile (necessarie n. 2 staffe per pergola) grafite Équerre enlevable pour positionner la pergola mobile au sol (utiliser 2 équerres par pergola) couleur graphite Bewegliches Profil zur Befestigung von Pfosten am Boden für bewegliche Pergola (für jede Pergola 2 Profile), Farbe grafitgrau</p>	STATSHIG
<p>Bracket in white for fixing to ground, white Staffa di fissaggio a terra bianca Équerre de fixation au sol blanche Pfostenschuh zur Befestigung der Pfosten am Boden für feste Pergolen, Farbe weiß</p>	SHISTAFB
<p>Bracket in white for fixing to ground, graphite Staffa di fissaggio a terra grafite Équerre de fixation au sol couleur graphite Pfostenschuh zur Befestigung der Pfosten am Boden für feste Pergolen, Farbe grafitgrau</p>	SHISTAFG
<p>Kit of 2 wheels Ø 10 Kit n. 2 ruote Ø 10 Kit de 2 roues Ø 10 Set mit 2 Rädern Ø 10</p>	KITRUSHI2

FINISHES / FINITURE / FINITIONS / AUSFÜHRUNGEN

	Aluminium powder coated graphite Alluminio verniciato a polveri grafite Aluminium galvanisé et thermolaqué graphite Pulverbeschichtetes Aluminium in grafitgrau		Aluminium powder coated white Alluminio verniciato a polveri bianco Aluminium galvanisé et thermolaqué blanc Pulverbeschichtetes Aluminium in weiß
	Ecru microperforated sheet Telo ecru microforato Tôle microperforée écru Ecrufarbenes, mikroperforiertes Tuch		Bamboo mat Stuoia bambù Natte de bambou Bambusmatte
			Painted wooden slats Listelli di legno verniciati Lattes de bois vernis Lackierte Holzleisten

→ Aluminium powder coated / Alluminio verniciato a polveri / Aluminium galvanisé et thermolaqué / Aluminium pulverbeschichtet

Solaire

WALL-MOUNTED PERGOLA CURVED ROOF / PERGOLA ADDOSSATA CURVA / PERGOLA ADOSSÉE COURBÉE ANBAUPERGOLA MIT GESCHWUNGENEM DACH

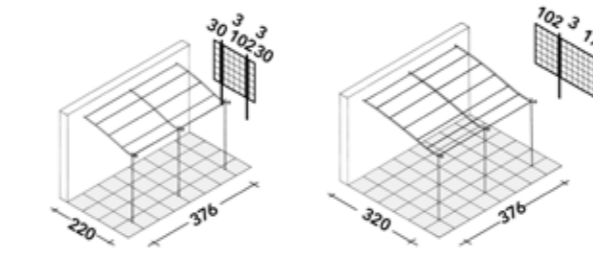

W 376 D 220 - 320

W 376 - Pergola / Pergola / Pergola / Pergola

D 220	PSW2C
D 320	PSW3C

W 186 - Extension / Estensione / Extension / Erweiterung

D 220	PSW2EC
D 320	PSW3EC

FREESTANDING PERGOLA CURVED ROOF / PERGOLA AUTOPORTANTE CURVA / PERGOLA AUTOPORTANTE COURBÉE FREI STEHENDE PERGOLA MIT GESCHWUNGENEM DACH

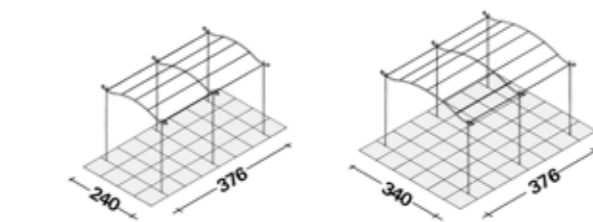

W 376 - 240 - 340

W 376 - Pergola / Pergola / Pergola / Pergola

D 240	PSA2C
D 340	PSA3C

W 186 - Extension / Estensione / Extension / Erweiterung

D 240	PSA2EC
D 340	PSA3EC

→ Iron graphite / Ferro grafite / Fer graphite / Eisen grafitgrau

Solaire

WALL-MOUNTED PERGOLA FLAT ROOF / PERGOLA ADDOSSATA PIANA / PERGOLA ADOSSÉE PLATE ANBAUPERGOLA MIT LINEAREM DACH

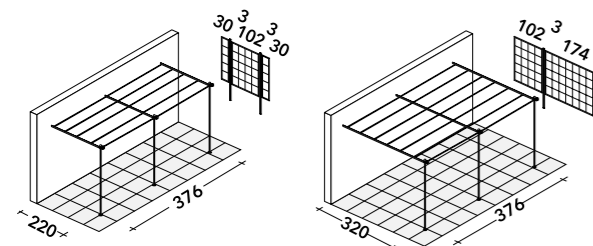

W 376 D 220 - 320

W 376 - Pergola / Pergola / Pergola / Pergola

D 220	PSP2C
D 320	PSP3C

W 186 - Extension / Estensione / Extension / Erweiterung

D 220	PSP2EC
D 320	PSP3EC

FREESTANDING PERGOLA FLAT ROOF / PERGOLA AUTOPORTANTE PIANA / PERGOLA AUTOPORTANTE PLATE FREI STEHENDE PERGOLA MIT LINEAREM DACH

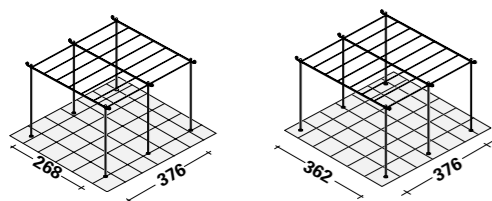

W 376 D 268 - 362

W 376 - Pergola / Pergola / Pergola / Pergola

D 268	PSAP2C
D 362	PSAP3C

W 186 - Extension / Estensione / Extension / Erweiterung

D 268	PSAP2EC
D 362	PSAP3EC

Dimensions given in the technical illustration refer to the maximum area occupied. The beam decoration overhangs the posts by approximately 20.5 cm in attached pergolas and by 18.5 cm in freestanding ones. Posts are Ø 3 cm H 250 cm. Thus the wall height of the curved attached pergola is: 280 cm for models 135 cm deep; 290 cm for models 220 cm deep; 310 cm for models 320 cm deep. Fixing kit excluded. /

Le misure riportate nei disegni si riferiscono agli ingombri massimi. Il decoro delle travi sporge rispetto ai pilastri di circa cm 20,5 nelle pergole addossate e di cm 18,5 in quelle autoportanti. I pilastri sono Ø cm 3 e H cm 250. La conseguente altezza a parete per le pergole addossate curve è di: cm 280 per il modello di profondità cm 135; cm 290 per il modello di profondità cm 220; cm 310 per il modello di profondità cm 320. Kit di fissaggio escluso. /

Les mesures reportées dans les dessins se réfèrent aux encombrements maximums. La décoration des travers dépassent d'environ 20,5 cm par rapport aux piliers pour les pergolas adossées et de 18,5 cm pour les pergolas autoportantes. Les piliers ont un Ø de 3 cm et H 250 cm. La hauteur conséquente au mur pour les pergolas adossées courbées est de : 280 cm pour le modèle de 135 cm de profondeur ; 290 cm pour le modèle de 220 cm de profondeur ; 310 cm pour le modèle de 320 cm de profondeur. kit de fixation exclu. /

Die in den Zeichnungen angegebenen Maße beziehen sich auf die Maximalmaße. Die Verzierung der Balken ragt bei Anbaupergolen ca. 20,5 cm und bei frei stehenden Pergolen ca. 18,5 cm über die Pfosten hinaus. Die Pfosten haben einen Durchmesser von 3 cm und eine Höhe von 250 cm. Die resultierende Wandhöhe für die gebogenen Pergolen beträgt: 280 cm für das 135 cm tiefe Modell; 290 cm für das 220 cm tiefe Modell; 310 cm für das 320 cm tiefe Modell. Befestigungssatz nicht im Lieferumfang enthalten. /

↳ Iron graphite / Ferro grafite / Fer graphite / Eisen grafitgrau

FIXED SHADES / TELI FISSI / TOILES FIXES / FESTE PLANEN

Kit for waterproof shade white (39% polyester coated with 61% PVC), complete with fixing components / Kit telo impermeabile bianco (poliestere 39% spalmato di PVC 61%), completo di elementi di fissaggio / Kit toile imperméable blanc (39% polyester enduit de 61% PVC), avec éléments de fixation / Bausatz für wasserfeste, weiße Plane (39% beschichtetes Polyester mit 61% PVC) /

For curved attached pergola, 220 cm deep / Per pergola addossata curva, cm 220 di profondità CO220 Pour pergola adossée courbée, de 220 cm de profondeur CO220 / Für geschwungene Anbaupergola, 220 Tiefe	CO220
With 1 extension / Con 1 estensione / Avec 1 extension / Mit einer Erweiterung	CO220E1
With 2 extensions / Con 2 estensioni / Avec 2 extensions / Mit zwei Erweiterungen	CO220E2
For curved attached pergola, 320 cm deep / Per pergola addossata curva, cm 320 di profondità CO320 Pour pergola adossée courbée, de 320 cm de profondeur CO320 / Für geschwungene Anbaupergola, 320 Tiefe	CO320
With 1 extension / Con 1 estensione / Avec 1 extension / Mit einer Erweiterung	CO320E1
With 2 extensions / Con 2 estensioni / Avec 2 extensions / Mit zwei Erweiterungen	CO320E2
For curved freestanding pergola, 240 cm deep / Per pergola autoportante curva, cm 240 di profondità CO240 Pour pergola autoportante courbée, de 240 cm de profondeur CO240 / Für geschwungene, frei stehende Pergola, 240 Tiefe	CO240
With 1 extension / Con 1 estensione / Avec 1 extension / Mit einer Erweiterung	CO240E1
With 2 extensions / Con 2 estensioni / Avec 2 extensions / Mit zwei Erweiterungen	CO240E2
For curved freestanding pergola, 340 cm deep / Per pergola autoportante curva, cm 340 di profondità CO340 Pour pergola autoportante courbée, de 340 cm de profondeur CO340 / Für geschwungene, frei stehende Pergola, 340 Tiefe	CO340
With 1 extension / Con 1 estensione / Avec 1 extension / Mit einer Erweiterung	CO340E1
With 2 extensions / Con 2 estensioni / Avec 2 extensions / Mit zwei Erweiterungen	CO340E2

To order roofing for pergolas with more than two extensions, substitute the "2" of the relative code of the pergola with two extensions, with the actual number of extensions (CO220E3 - CO220E4) Per ordinare coperture di pergole con più di 2 estensioni, sostituire il "2" nei codici relativi alle pergole con 2 estensioni con il numero di quelle previste (es. CO220E3 - CO220E4) Pour commander les couvertures des pergolas ayant plus de 2 extensions, remplacer le "2" dans les codes relatifs aux pergolas avec 2 extensions, avec le numéro des pergolas désirées (ex. CO220E3 - CO220E4) Für Überdachungen für Pergolen mit mehr als 2 Erweiterungen ersetzen Sie die Nummer „2“ in der Artikelnummer mit der Anzahl der gewünschten Erweiterungen (Bsp. CO220E3 - CO220E4) /

BAMBOO SHADES / STUOIE DI CANNE DI BAMBÙ / NATTES EN CANNES DE BAMBOU / BAMBUSMATTEN

Kit for bamboo shades made with bamboo canes of varying diameter (from 1 cm to 2 cm each) connected with a stainless steel wire. The kit includes fitting components / Kit di stuoie realizzate con canne di bambù di sezione variabile (da cm 1 a cm 2 ca.) e unite da un filo passante di acciaio inox. I kit sono completi di elementi di fissaggio / Kit de nattes réalisées en cannes de bambou de section variant de 1 cm à 2 cm environ et reliées par un fil en acier inoxydable. Eléments de fixation compris dans le kit. / Satz Bambusmatten gefertigt aus Bambusstäben mit variablem Schnittdurchmesser (von 1 cm bis ca. 2 cm), verbunden mit Inox-Edelstahldraht, komplett mit Befestigungsmaterial /

Structure / Struture / Structures / Pergolen	
PSA2EC - PSW2EC - PSP2EC - PSAP2EC	COBAM1
PSW2C - PSP2C - PSA2C - PSAP2C - PSW3EC - PSP3EC - PSA3EC - PSAP3EC - PSW3EC - PSP3EC PSA3EC - PSAP3EC	COBAM2
PSW3C - PSP3C - PSA3C - PSAP3C	COBAM3

↳ Iron graphite / Ferro grafite / Fer graphite / Eisen grafitgrau

Solaire

ROLL SHADES / TELI SCORREVOLI / TOILES COULISSANTES / FEDERZUGROLLOS

Kit for adjustable shade in 100% acrylic, colour écreu complete with powder coated aluminium casing, spring retractable mechanism with tracks, for attached pergolas and extensions / Kit telo regolabile di acrilico 100% colore écreu, completo di coprirullo di alluminio verniciato a polveri, avvolgibile a molla e guide, per pergole addossate ed estensioni / Kit toile réglable en 100% acrylique couleur écreu avec coffre pour rouleau en aluminium thermolaqué, enrouleur à ressort et glissières, pour pergolas adossées et extensions. / Bausatz für verschiebbare Bespannung aus 100% naturfarbenem Acrylstoff, komplett mit grafitgrau beschichteter Blende aus Aluminium, Federmechanik und Schienen für Anbaupergolen und Erweiterungen.

Kit for adjustable shade white (29% polyester coated with 71% PVC) complete with powder coated aluminium casing, graphite, spring retractable mechanism with tracks, for attached pergolas and extensions / Kit telo regolabile impermeabile bianco (poliestere 29% spalmato di PVC 71%), completo di coprirullo di alluminio verniciato a polveri grafite, avvolgibile a molla e guide, per pergole addossate ed estensioni / Kit toile réglable imperméable blanc (29% polyester enduit de 71% PVC), avec coffre pour rouleau en aluminium thermolaqué, enrouleur à ressort et glissières, pour pergolas adossées et extensions. / Bausatz für weiße wasserundurchlässige Tuchbespannung (29% Polyester - 71% PVC-Beschichtung), komplett mit grafitgrau beschichteter Blende aus Aluminium, Federmechanik und Schienen für Anbaupergolen und Erweiterungen.

Structure / Strutture / Structures / Pergolen

PSW2C	CORUS2
PSW2EC	CORUS2E
PSW3C	CORUS3
PSW3EC	CORUS3E
PSP2C	CORUSP2
PSP2EC	CORUSP2E
PSP3C	CORUSP3
PSP3EC	CORUSP3E

Structure / Strutture / Structures / Pergolen

PSW2C	CORUS2PVC
PSW2EC	CORUS2EPVC
PSW3C	CORUS3PVC
PSW3EC	CORUS3EPVC

PANELS IN DIAMOND PATTERN / PANNELLI A MAGLIA ROMBOIDALE / PANNEAUX MAILLE LOSANGE / PANEEL MIT RAUTENMUSTER

Grilles in iron with 13 x 13 cm perforated pattern in sheet metal with folded edges (W x H) / Grigliati di ferro con maglia di cm 13 x 13 in lamiera forata e bordo ripiegato (L x H) / Treillages en fer à mailles de 13 x 13 en tôle perforée et bord plié (L x H) / Gitter aus Eisen mit 13 x 13 cm großen Rauten aus Blech mit gefalteten Kanten (Breite / Höhe)

	30 x 102	GRFR12
	30 x 150	GRFR13
	102 x 102	GRFR22
	102 x 150	GRFR23
	174 x 102	GRFR42



PANELS IN SQUARE PATTERN / PANNELLI A MAGLIA QUADRATA / PANNEAUX MAILLE CARRÉE / PANEEL MIT QUADRATISCHEM MUSTER

Grilles in iron 23,2 x 23,2 cm square pattern of crisscrossed iron rods within a frame (W x H) / Grigliati di ferro con maglia di cm 23,2 x 23,2 in tondini di ferro sovrapposti e racchiusi in un telaio (L x H) / Treillages maille carrée 23,2 x 23,2 en barres de fer superposés et montées sur châssis (L x H) / Gitter aus Eisen 23,2 x 23,2 cm quadratisches Muster aus gekreuzten Eisenstäben innerhalb eines Rahmens (B x H)

	30 x 102	GRF12
	30 x 150	GRF13
	102 x 102	GRF22
	102 x 150	GRF23
	150 x 150	GRF33
	174 x 102	GRF42
	174 x 150	GRF43

CAPPING PIECES / ELEMENTO DI CORONAMENTO / COURONNEMENT / ZIERLEISTEN

Components Ø 2 in iron to fix between two posts, alone or with the relative grilles / Elementi Ø 2 di ferro da utilizzare tra due pilastri, da soli o con i rigliati corrispondenti / Éléments Ø 2 en fer à utiliser entre deux piliers, seuls ou avec les treillages correspondants / Eisenelemente Ø 2 zwischen zwei Pfosten, einzeln oder mit den entsprechenden Rankgittern (gerade)

Straight / Lineare / Linéaire / Gerade	Length / Lunghezza / Longueur / Länge	
	39	COF1L
	111	COF2L
	159	COF3L
	183	COF4L
Curved / Curvilineo / Arqué / Gebogen	Length / Lunghezza / Longueur / Länge	
	111	COF2C
	159	COF3C
	183	COF4C



→ Iron graphite / Ferro grafite / Fer graphite / Eisen grafitgrau

→ Iron graphite / Ferro grafite / Fer graphite / Eisen grafitgrau

Solaire

POSTS H 75 / PILASTRI H 75 / PILIERS H 75 / PFOSTEN HÖHE H 75



Post Ø 3 H 75 in iron with fixing bracket, bracket cover and ball finial decoration / Pilastro Ø 3 H 75 di ferro con staffa di fissaggio e copristaffa, decoro finale a sfera / Pilier Ø 3 H 75 en fer avec équerre pour fixation et cache pour équerre, boule d'ornement finale / Eisenpfosten Ø 3, 75 h mit Befestigungsprofil und Profillabdeckung, mit Kugeldekor mit Verbindungen zur Befestigung von Rankgittern

	*** Single with couplings for fixing grilles / *** Singolo con giunti per fissaggio grigliati *** Simple avec joints pour fixation des treillages / ***Einzel mit Verbindungen um Gitter zu befestigen	PFS75C
	Double with couplings for fixing grilles / Doppio con giunti per fissaggio grigliati Double avec joints pour fixation des treillages / Doppelt mit Verbindungen um Gitter zu befestigen	PFD75C

- (*) Single posts, couplings excluded, used to fix capping pieces, while single posts with couplings are used for bridging and creating openings.
 (**) Components can be cut to size, according to the width of the gap to be bridged.
 (***) Each post is fixed to the parapet using brackets with 3 masonry plugs Ref. TFP or with chemical plugs Ref. TC6SP according to the nature of the parapet.
 (*) I pilastri singoli, giunti esclusi, si utilizzano per il fissaggio di elementi di coronamento, mentre per gli elementi di compensazione e affaccio si utilizzano pilastri singoli con giunti.
 (**) Gli elementi possono essere tagliati su misura, in funzione del perimetro da schermare.
 (***) Il fissaggio di ogni pilastro singolo sul parapetto per mezzo della staffa avviene con 3 tasselli ad espansione Art. TFP o con tasselli chimici Art. TC6SP, da scegliere a seconda della natura del parapetto.
 (*) Les piliers simples, sans joints, s'utilisent pour la fixation des éléments de couronnement tandis que pour les éléments de compensation et de raccords utiliser des piliers simples avec joints.
 (**) Les éléments peuvent être découpés sur mesure, en fonction du périmètre à clôturer.
 (***) La fixation de chaque pilier simple au parapet à l'aide d'une équerre est faite avec 3 chevilles à expansion Réf. TFP ou avec des chevilles chimiques Réf. TC6SP en fonction du type de parapet.
 (*) Einzelfposten, ohne Verbindungen, werden für die Befestigung von Zierleisten verwendet, während Einzelfposten mit Verbindungen für Ausgleichselemente verwendet werden.
 (**) Die Elemente können nach Maß zugeschnitten werden, um eine Lücke auszufüllen
 (***) Die Pfosten werden am Mauerwerk mittels Profilen mit 3 Spreizdübeln Art. TFP oder mit chemischen Dübeln Art. TC6SP, je nach Beschaffenheit des Mauerwerks, befestigt.

POSTS H 260 / PILASTRI H 260 / PILIERS H 260 / PFOSTEN H 260

Post Ø 3 H 260 in iron with ball finial decoration / Pilastro Ø 3 H 260 di ferro con decoro finale a sfera / Piliers Ø 3 H 260 en fer avec boule d'ornement final / Pfosten Ø 3 H 260 aus Eisen mit einer dekorativen Kugel als Abschluss.

	Single with couplings for fixing grilles / Singolo con giunti per fissaggio grigliati / Simple avec joints pour fixation des treillages / Einzel mit Verbindungen zur Befestigung von Trenngittern	PFSG
	* Double with couplings for fixing grilles / * Doppio con giunti per fissaggio grigliati / * Double avec joints pour fixation des treillages / * Doppelt mit Verbindungen zur Befestigung von Trenngittern	PFDG
	Single, couplings not included / Singolo, giunti esclusi / Simple, joints exclus / Einfach, ohne Verbindungen	PFS

BRIDGE OPENING ** / COMPENSAZIONE - AFFACCIO ** / ÉLÉMENTS DE COMPENSATION - RACCORDS ** / AUSGLEICHSELEMENT **

Components including 2 capitals and 1 connecting piece in iron to bridge a gap and create an entrance / Elementi composti da 2 capitelli e 1 profilo di giunzione di ferro per realizzare zone di compensazione e affaccio / Éléments composés de 2 chapiteaux et d'un profilé de jonction en fer pour réaliser des zones de compensations et de raccords / Komponenten mit 2 Kapitellen und 1 Verbindungsstück aus Eisen, zur Überbrückung einer Lücke und um einen Eingang zu schaffen

	L 183	ECF183
	L 262	ECF262

→ Iron graphite / Ferro grafite / Fer graphite / Eisen grafitgrau

FITTING COMPONENTS / FISSAGGI / FIXATIONS / BEFESTIGUNGSELEMENTE / BEFESTIGUNGSELEMENTE

Bracket for fixing one post to the ground, complete with 3 plugs, Ø mm 10 / Staffa per fissaggio a terra di 1 pilastro, completa di 3 tasselli ad espansione, Ø mm 10 / Équerre pour fixer au sol 1 pilier, avec 3 chevilles à expansion Ø 10 mm / Befestigungsscheibe für einen Pfosten am Boden komplett mit 3 Spreizdübeln Ø 10 mm

SAPS

Hardware kit for fixing one panel to posts / Kit ferramenta per il fissaggio di un pannello ai pilastri / Paire d'équerres pour fixation d'un pilier
Beschlägeset zur Befestigung eines Panels an den Pfosten



EFP4

Pair of brackets for fixing post / Coppia di staffe per fissare il pilastro / Paire d'équerres pour fixation d'un pilier / Halterungen zur Befestigung von Pfosten



To masonry parapet / Al parapetto in muratura / À un parapet en maçonnerie
Profile zur Befestigung der Pfosten am Mauerwerk

SFP2



To iron railing / Alla ringhiera in ferro / À une balustrade en fer / Profile zur Befestigung der Pfosten am Eisengeländer

SFR2



Aluminium coupling for iron post / Giunto di alluminio per pilastro in ferro
Joint en aluminium pour pilier en fer / Aluverbindung für Eisenpfosten

G33NC

PAVILION / PADIGLIONE / GLORIETTE / PAVILLON

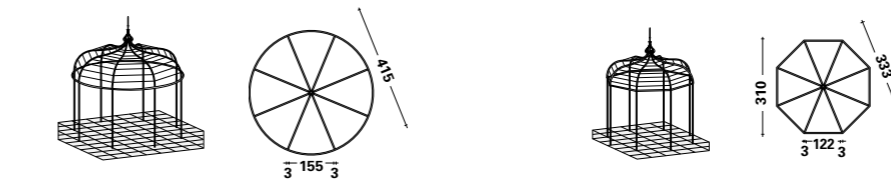

Ø 415 with 8 - round posts

octagonal side 122 (max Ø 333)

Pavilion round Ø 415 with 8 round posts Ø 3 H 250 in iron and galvanized steel wire
Rotondo Ø 415 con 8 pilastri rotondi Ø 3 di ferro e filo di acciaio zincato
Ronde Ø 415 avec 8 piliers ronds Ø 3 H 250 en fer et fil d'acier galvanisé
Pavillon rund Ø 415 mit 8 runden Eisenpfosten Ø 3, H 250 mit verzinktem Stahldraht

PATRR

Pavilion octagonal side 122 (max Ø 333) with 8 round posts Ø 3 H 250 in iron and galvanized steel wire
Padiglione ottagonale lato 122 (max Ø 333) con 8 pilastri rotondi Ø 3 H 250 di ferro e filo di acciaio zincato
Octogonale côté 122 cm (max Ø 333) avec 8 piliers ronds Ø 3 H 250 en fer et fil d'acier galvanisé
Pavillon achteckig Seitenlänge 122 (max. Ø 333) mit 8 runden Eisenpfosten Ø 3, H 250 mit verzinktem Stahldraht

PATRO

Grilles 102 cm wide are suitable for octagonal pavilions, and grilles 150 cm wide for round pavilions. Fixing kit excluded
Per il padiglione ottagonale sono adatti grigliati di larghezza cm 102; per il modello rotondo, grigliati di larghezza cm 150. Kit di fissaggio escluso
Pour les gloriettes octogonales choisir les treillages de 102 cm de largeur; pour les gloriettes rondes choisir les treillages de 150 cm de largeur. Kit de fixation exclu.
Für den achteckigen Pavillon eignen sich Trenngitter von 102 cm Breite; für das runde Modell Trenngitter von 150 cm Breite. Befestigungsmaterial nicht beinhaltet.

→ Iron graphite / Ferro grafite / Fer graphite / Eisen grafitgrau

Solaire

WATERPROOF COVERS / TELI DI COPERTURA / TOILE IMPERMÉABLES / WASSERUNDURCHLÄSSIGE TUCHBESpannung

Waterproof cover with fittings for pavilion Telo impermeabile con fissaggi Toile imperméable avec fixation Wasserundurchlässige Tuchbespannung mit Befestigungsmaterial für Pavillon	for round pavilion / per padiglione rotondo pour gloriette ronde / für runden Pavillon	TINTR
	for octagonal pavilion / per padiglione ottagonale pour gloriette octogonale / für achteckigen Pavillon	TINTO

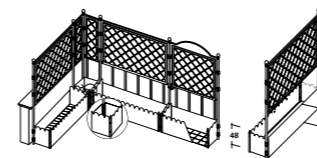

Wall-mounted Solaire planters must only be used with posts, grilles and the other accessories suggested on these and previous pages. 4 aluminium couplings Ref. G33NC, are necessary for fixing to posts, making the length of the planters 37, 109, 157 e 181 cm and respectively compatible with 30, 102, 150 e 174 cm grilles. A 42,5 x 42,5 cm corner unit is also available.

Le fioriere Solaire adossate devono essere utilizzate esclusivamente con i pilastri, i grigliati e gli altri accessori proposti in queste e nelle precedenti pagine. Per fissarle ai pilastri sono necessari 4 giunti in alluminio Art. G33NC che rendono le fioriere di lunghezza cm 37, 109, 157 e 181 compatibili rispettivamente con i grigliati di cm 30, 102, 150 e 174. È disponibile una variante d'angolo di cm 42,5 x 42,5.

Les jardinières Solaire adossées doivent être utilisées exclusivement avec les piliers, les treillages et les autres accessoires proposés dans ces pages. Pour les fixer aux piliers utiliser 4 joints en aluminium Réf. G33NC, p. 214 rendant ainsi compatibles, respectivement, les jardinières de 37, 109, 157 et 181 cm de longueur avec les treillages de 30, 102, 150 et 174 cm. Un modèle d'angle de 42,5 x 42,5 cm est également disponible. Die Anbaukästen Solaire sind nur mit den auf den vorhergehenden Seiten beschriebenen Pfosten, Rankgittern und Elementen zu verwenden. Um sie an den Pfosten zu befestigen, werden 4 Verbindungselemente aus Aluminium Art. G33NC benötigt, sodass die 37, 109, 157 und 181 breiten Blumenkästen zu den 30, 102, 150 und 174 langen Rankgittern passen. Es ist auch eine Eckversion von 42,5 x 42,5 cm erhältlich.

ACCESSORIES / ACCESSORI / ACCESSOIRES / ACCESSOIRES / ZUBEHÖR

	Coupling in aluminium for fixing iron grilles to pavilion / Giunto in alluminio per il fissaggio dei grigliati in ferro ai padiglioni / Joint en aluminium pour fixation des treillages en fer aux gloriettes / Aluverbindung für die Befestigung der Trenngitter aus Eisen an den Pavillon	G33NCT
	Hardware kit in aluminium for fixing 1 square or diamond pattern metal grille to octagonal pavilion / Kit ferramenta in alluminio per il fissaggio di 1 grigliato in ferro sia a maglia quadrata che romboidale al padiglione ottagonale / Kit pièces en aluminium pour fixation d'un treillage en fer à mailles carrées ou losanges à la gloriette octogonale / Beschläge-Set aus Aluminium für die Befestigung eines Trenngitters aus Eisen mit quadratischem Muster oder mit Rautenmuster am achteckigen Pavillon	EFP4TO
	Hardware kit in aluminium for fixing 1 iron diamond patterned grille to round pavilion / Kit ferramenta in alluminio per il fissaggio di 1 grigliato in ferro a maglia romboidale al padiglione rotondo / Kit pièces en aluminium pour fixation d'un treillage en fer à la gloriette ronde à maille losange / Beschlägeset aus Aluminium für die Befestigung eines Trenngitters mit Rautenmuster aus Eisen am runden Pavillon	EFPR4TR
	Hardware kit in aluminium for fixing 1 iron square patterned grille to round pavilion / Kit ferramenta in alluminio per il fissaggio di 1 grigliato in ferro a maglia quadrata al padiglione rotondo / Kit pièces en aluminium pour fixation d'un treillage en fer à la gloriette ronde à maille carrée / Beschlägeset aus Aluminium für die Befestigung eines Trenngitters mit quadratischem Muster aus Eisen am runden Pavillon	EFPQ4TR
	Bracket for fixing one post to the ground, complete with Ø 10 mm plugs / Staffa per fissaggio a terra di 1 pilastro, completa di 3 tasselli ad espansione Ø mm 10 / Équerre pour fixer au sol 1 pilier, avec 3 chevilles à expansion Ø 10 mm / Befestigungsscheibe für einen Pfosten am Boden komplett mit 3 Sprezdübeln Ø 10 mm	SAPS

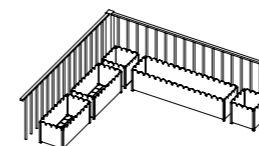

Freestanding planters can only be used as autonomous units and although compatible with items of the Collection, they cannot be affixed to them. Therefore they must be used as separate features or where grilles have already been installed.

Le fioriere Solaire autoportanti possono essere utilizzate solo come strutture autonome in quanto, pur essendo compatibili con gli elementi della collezione, non possono essere fissate ad essi. Devono essere quindi usate in modo indipendente o nel caso in cui i grigliati siano già stati fissati.

Les jardinières Solaire autoportantes peuvent être utilisées uniquement comme structures autonomes car bien qu'étant compatibles avec les éléments du Système, elles ne peuvent pas être fixées à ces dernières. Elles doivent donc être utilisées de façon indépendante ou dans le cas où les treillages aient déjà été fixés.

Die frei stehenden Pflanzkästen Solaire können nur als eigenständige Elemente verwendet werden, da sie nicht am System befestigt werden können, auch wenn sie zu den Elementen des Systems passen. Sie können überall dort eingesetzt werden, wo sie frei stehen oder wo die Trenngitter bereits befestigt wurden.

PLANTERS / FIORIERE / JARDINIÈRES / BLUMENKÄSTEN

	Wall-mounted / Adossate / Adossées / Anbau		
		37 x 42,5	FRS37
		42,5 x 42,5	FRS41
		109 x 42,5	FRS109
		157 x 42,5	FRS157
		181 x 42,5	FRS181

	Freestanding / Autoportanti / Autoportantes / Frei stehend		
		45 x 45	FARS45
		109 x 45	FARS109
		157 x 45	FARS157
		181 x 45	FARS181



FINISHES / FINITURE / FINITIONS / AUSFÜHRUNGEN

Powder coated galvanized iron graphite
Ferro zincato verniciato a polveri grafite
Fer galvanisé enduit de poudre graphite
Verzinktes, pulverbeschichtetes Eisen grafitgrau

White PVC sheet
Telo bianco PVC
Tôle PVC blanche
Weiße PVC Plane

100% acrylic fabric in white
Tessuto acrilico 100% bianco
Tissu 100% acrylique blanc
Weißer Stoff aus 100% Acryl

Bamboo mat
Stuoia bambù
Natte de bambou
Bambusmatte

→ Iron graphite / Ferro grafite / Fer graphite / Eisen grafitgrau

→ Iron graphite / Ferro grafite / Fer graphite / Eisen grafitgrau

Tibisco

FREESTANDING PERGOLA WITHOUT ROOFING* / PERGOLA AUTOPORTANTE SENZA COPERTURA* PERGOLA AUTOPORTANTE SANS COUVERTURE* / FREI STEHENDE PERGOLA OHNE BEDACHUNG*

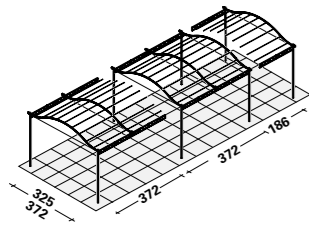

W 376 D 366 - 413

W 376 - Pergola / Pergola / Pergola / Pergola

D 366 **PEA366**

D 413 **PEA413**

W 186 - Extension / Estensione / Extension / Erweiterung

D 366 **EEA366**

D 413 **EEA413**

W 372 - Extension / Estensione / Extension / Erweiterung

D 366 **EEA366D**

D 413 **EEA413D**

Fixing kit excluded / Kit di fissaggio escluso / kit de fixation exclu / Ohne Befestigungsmaterial

WALL-MOUNTED PERGOLA WITHOUT ROOFING** / PERGOLA ADDOSSATA SENZA COPERTURA** PERGOLA ADOSSÉE SANS COUVERTURE** / ANBAUPERGOLA OHNE BEDACHUNG**

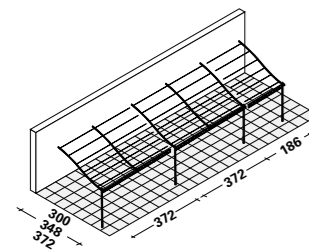

W 376 D 321 - 369 - 393

W 376 - Pergola / Pergola / Pergola / Pergola

D 321 **PE321**

D 369 **PE369**

D 393 **PE393**

W 186 - Extension / Estensione / Extension / Erweiterung

D 321 **EE321**

D 369 **EE369**

D 393 **EE393**

W 372 - Extension / Estensione / Extension / Erweiterung

D 321 **EE321D**

D 369 **EE369D**

D 393 **EE393D**

Fixing kit excluded / Kit di fissaggio escluso / kit de fixation exclu / Ohne Befestigungsmaterial

Maximum width to wall 385 cm. The relative measurements between posts are given in the technical illustration. The beam spirals overhang the posts by 18,5 cm.

L'ingombro totale a parete è di cm 385. Nei disegni sono riportate le misure di interesse tra i pilastri. Le volute delle travi sporgono di cm 18,5 rispetto ai pilastri.

L'encombrement total au mur est de 385 cm. Les mesures reportées dans les dessins sont les mesures entraxes des piliers. Les volutes des piliers dépassent de 18,5 cm par rapport aux piliers.

Das gesamte Richtmaß an der Wand beträgt 385 cm. In der Zeichnung sind die Maße für den Achsabstand zwischen den Pfosten angegeben. Die Voluten der Balken ragen 18,5 cm über die Pfosten hinaus.

→ Iron graphite / Ferro grafite / Fer graphite / Eisen grafitgrau

WALL-MOUNTED PERGOLA WITH POLYCARBONATE ROOF** / PERGOLA ADDOSSATA CON COPERTURA IN POLICARBONATO** PERGOLA ADOSSÉE AVEC COUVERTURE EN POLYCARBONATE** / ANBAUPERGOLA MIT BEDACHUNG AUS POLYKARBONAT**

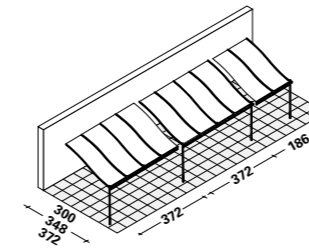

Maximum width to wall 385 cm.
L'ingombro totale a parete è di cm 385.
L'encombrement total au mur est de 385 cm.
Das gesamte Richtmaß an der Wand beträgt 385 cm.

W 376 D 321 - 369 - 393

W 376 - Pergola / Pergola / Pergola / Pergola

D 321 **PE321PC**

D 369 **PE369PC**

D 393 **PE393PC**

W 186 - Extension / Estensione / Extension / Erweiterung

D 321 **EE321PC**

D 369 **EE369PC**

D 393 **EE393PC**

W 372 - Extension / Estensione / Extension / Erweiterung

D 321 **EE321DPC**

D 369 **EE369DPC**

D 393 **EE393DPC**

Fixing kit excluded / Kit di fissaggio escluso / kit de fixation exclu / Ohne Befestigungsmaterial

*Freestanding pergolas have 4 x 4 cm posts H 280 which must be fixed to the ground, set in concrete to a depth of 40 cm

*Le pergole autoportanti hanno pilastri di cm 4 x 4 h cm 280 che devono essere fissati a terra, cementandoli, per circa cm 40.

* Les pergolas autoportantes ont des piliers de 4 x 4 cm h 280 cm qui doivent être fixés au sol dans à peu près 40 cm de ciment.

*Die frei stehenden Pergolen verfügen über Pfosten von 4 x 4 cm, H 280 und müssen 40 cm tief in den Boden zementiert werden.

**Attached pergolas have 4 x 4 cm posts H 240 with a wall height of:

- 280 cm for models 321 cm deep;

- 285 cm for models 369 cm deep;

- 292 cm for models 393 cm deep.

**Le pergole addossate hanno pilastri di cm 4 x 4 H cm 240 con altezza a parete di:

- cm 280 per i modelli di profondità cm 321;

- cm 285 per i modelli di profondità cm 369;

- cm 292 per i modelli di profondità cm 393.

**Les pergolas adossées ont des piliers de 4 x 4 cm H 240 cm avec hauteur au mur de:

- 280 cm pour les modèles de 321 cm de profondeur ;

- 285 cm pour les modèles de 369 cm de profondeur ;

- 292 cm pour les modèles de 393 cm de profondeur.

**Die Anbaupergolen verfügen über Pfosten von 4 x 4 cm, H 240 cm mit der entsprechenden Höhe an der Wand

- 280 cm für die 321 cm tiefen Modelle;

- 285 cm für die 369 cm tiefen Modelle;

- 292 cm für die 393 cm tiefen Modelle.

→ Iron graphite / Ferro grafite / Fer graphite / Eisen grafitgrau

Tibisco

PAVILION / PADIGLIONE / GLORIETTE / PAVILLON

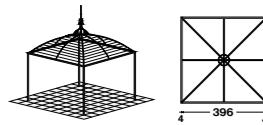

W 404 D 404 posts 4 x 4 H 280 / L 404 P 404 pilastri 4 x 4 H 280 / L 404 P 404 pilastri 4 x 4 H 280 / L 404 P 404 Pfosten 4 x 4 H 280

Pavilion complete with 4 posts 4 x 4 H 280 / Padiglione completo di 4 pilastri 4 x 4 H 280
Gloriette avec 4 piliers 4 x 4 H 280 / Pavillon komplett mit 4 Pfosten 4 x 4 H 280





PTD400

Waterproof cover / Telo impermeabile / Toile imperméable / Wasserundurchlässige Tuchbespannung

TPF400









Fixing kit excluded / Kit di fissaggio escluso / kit de fixation exclu / Ohne Befestigungsmaterial

ACCESSORIES / ACCESSORI / ACCESSOIRES / ACCESSOIRES / ZUBEHÖR

	Bracket for fixing 4 x 4 posts to the ground Staffa per il fissaggio a terra di pilastri 4 x 4 Équerre pour fixation piliers 4 x 4 cm au sol Pfostenschuh zur Befestigung der 4 x 4 Pfosten am Boden	SFPGS
	Pair of brackets for fixing 4 x 4 posts to parapet Coppia di staffe per il fissaggio a parapetto di pilastri 4 x 4 Paire d'équerres pour fixation de piliers 4 x 4 cm à parapet 2 Schraubprofile zur Befestigung der 4 x 4 Pfosten an der Brüstung	SFPQ2
	Pair of brackets for fixing 4 x 4 posts to railing Coppia di staffe per il fissaggio a ringhiera di pilastri 4 x 4 Paire d'équerres pour fixation de piliers 4 x 4 cm à garde-corps 2 Profile zur Befestigung der 4 x 4 starken Pfosten am Geländer	SFRQ2
	Set of 2 spandrels W 98 H 98 with fittings Set di 2 semiarchi L 98 H 98 con fissaggi Set de 2 arceaux L 98 H 98 avec fixations Set mit 2 Halbbögen aus Eisen B 98 H 98 mit Befestigungsmaterial	CAFER2
	Decorative base post H 30 with bracket for fixing to ground Decoro di base H 30 per pilastro con staffa di fissaggio a terra Décor pour base du pilier H 30 avec équerre pour fixation au sol Basisdekor H 30 für Eisenpfosten mit Befestigungsplatte	DBC

- Iron graphite / Ferro grafite / Fer graphite / Eisen grafitgrau

PRESTIGE COUPLING - FITTINGS / GIUNTO PRESTIGE - FISSAGGI / JOINT PRESTIGE - FIXATIONS / PRESTIGE VERBINDUNG UND BEFESTIGUNGEN

	Coupling Prestige 5,5 x 5,5 cm H 6 in aluminium with powder coated fittings in graphite, for fixing grilles and planters to 4 x 4 iron posts Giunto Prestige 5,5 x 5,5 H 6 cm di alluminio con fissaggi verniciati a polveri grafite, per fissare grigliati e fioriere a pilastri in ferro di 4 x 4 Joint Prestige 5,5 x 5,5 H 6 cm en aluminium avec fixations thermolaquées couleur graphite, pour fixer treillages et jardinières aux piliers en fer de 4 x 4 cm Aluverbindung Prestige mit Befestigungen, 5,5 x 5,5, H 6 grafitgrau pulverbeschichtet, um Trenngitter und Blumenkästen an 4 x 4 Pfosten zu befestigen	G55NC
	Kit of 4 components for fixing graphite iron grilles Kit di 4 elementi per fissaggio di grigliati in ferro Kit de 4 éléments pour fixer les treillages en fer, couleur graphite Set mit 4 Abstandhaltern für Rankgitter aus grafitgrauem Eisen	EFP4
	Bracket for fixing graphite iron grilles to the wall Staffa per il fissaggio a parete di grigliati in ferro Équerre pour fixer au mur les treillages en fer, couleur graphite Schraubprofil zur Befestigung der Trenngitter aus grafitgrauem Eisen an der Wand	SFPG
	Bracket for fixing 4 x 4 cm posts to the ground Staffa per il fissaggio a terra di pilastri 4 x 4 cm Équerre pour fixer au sol les piliers 4 x 4 cm Pfostenschuh zur Befestigung der 4 x 4 Pfosten am Boden	SFPGS
	Pair of brackets for fixing 4 x 4 cm posts to parapet Coppia di staffe per il fissaggio al parapetto di pilastri 4 x 4 cm Paire d'équerres pour fixer piliers 4 x 4 cm à parapet 2 Profile zur Befestigung der 4 x 4 starken Pfosten an der Brüstung	SFPQ2
	Pair of brackets for fixing 4 x 4 cm posts to railing Coppia di staffe per il fissaggio alla ringhiera di pilastri 4 x 4 cm Paire d'équerres pour fixer piliers 4 x 4 cm à la balustrade 2 Profile zur Befestigung der 4 x 4 starken Pfosten am Geländer	SFRQ2
	Post 4 x 4 H 240 cm in iron with fittings for fixing to decorated beam Pilastro 4 x 4 H 240 cm in ferro con fissaggi alla trave decorata Pilier 4 x 4 H 240 cm en fer avec fixations à la poutre décorée Eisenpfosten 4 x 4, 240 h mit Befestigungen am verzierten Träger	PQF
	Post 4 x 4 H 240 cm in iron with "ball" for Tibisco pergola Pilastro 4 x 4 H 240 cm in ferro con "sfera", per pergola Tibisco Pilier 4 x 4 H 240 cm en fer avec boule d'ornement, pour pergola Tibisco Eisenpfosten 4 x 4, 240 h mit Kugeldekor für Pergola Tibisco	PQS

- Iron graphite / Ferro grafite / Fer graphite / Eisen grafitgrau

Tibisco

FIXED SHADES / TELI FISSI / TOILES FIXES / FESTE PLANEN

Kit for waterproof shade white (39% polyester coated with 61% PVC), complete with fixing components for attached pergolas 321 cm deep Kit telo impermeabile bianco (poliestere 39% spalmato di PVC 61%), completo di elementi di fissaggio per pergola addossata, di profondità cm 321 Kit toile imperméable blanche (39% polyester enduit de 61% PVC), éléments de fixation inclus pour pergola adossée de 321 cm de profondeur Bausatz aus wasserdichter weißer Plane (39% Polyester mit 61% PVC-Beschichtung), komplett mit Befestigungsmaterial für Anbaupergola mit 321 cm Tiefe	CO321
Kit for waterproof shade white (39% polyester coated with 61% PVC), complete with fixing components for attached pergolas 321 cm deep with 1 extension Kit telo impermeabile bianco (poliestere 39% spalmato di PVC 61%), completo di elementi di fissaggio per pergola addossata, di profondità cm 321 con 1 estensione Kit toile imperméable blanche (39% polyester enduit de 61% PVC), éléments de fixation inclus pour pergola adossée de 321 cm de profondeur avec 1 extension Bausatz aus wasserdichter weißer Plane (39% Polyester mit 61% PVC-Beschichtung), komplett mit Befestigungsmaterial für Anbaupergola mit 321 cm Tiefe und einer Erweiterung	CO321E1
Kit for waterproof shade white (39% polyester coated with 61% PVC), complete with fixing components for attached pergolas 321 cm deep with 2 extension Kit telo impermeabile bianco (poliestere 39% spalmato di PVC 61%), completo di elementi di fissaggio per pergola addossata, di profondità cm 321 con 2 estensioni Kit toile imperméable blanche (39% polyester enduit de 61% PVC), éléments de fixation inclus pour pergola adossée de 321 cm de profondeur avec 2 extensions Bausatz aus wasserdichter weißer Plane (39% Polyester mit 61% PVC-Beschichtung), komplett mit Befestigungsmaterial für Anbaupergola mit 321 cm Tiefe und zwei Erweiterungen	CO321E2
Kit for waterproof shade white (39% polyester coated with 61% PVC), complete with fixing components for attached pergolas 369 cm deep Kit telo impermeabile bianco (poliestere 39% spalmato di PVC 61%), completo di elementi di fissaggio per pergola addossata, di profondità cm 369 Kit toile imperméable blanche (39% polyester enduit de 61% PVC), éléments de fixation inclus pour pergola adossée de 369 cm de profondeur Bausatz aus wasserdichter weißer Plane (39% Polyester mit 61% PVC-Beschichtung), komplett mit Befestigungsmaterial für Anbaupergola mit 369 cm Tiefe.	CO369
Kit for waterproof shade white (39% polyester coated with 61% PVC), complete with fixing components for attached pergolas 369 cm deep with 1 extension Kit telo impermeabile bianco (poliestere 39% spalmato di PVC 61%), completo di elementi di fissaggio per pergola addossata, di profondità cm 369 con 1 estensione Kit toile imperméable blanche (39% polyester enduit de 61% PVC), éléments de fixation inclus pour pergola adossée de 369 cm de profondeur avec 1 extension Bausatz aus wasserdichter weißer Plane (39% Polyester mit 61% PVC-Beschichtung), komplett mit Befestigungsmaterial für Anbaupergola mit 369 cm Tiefe und einer Erweiterung	CO369E1
Kit for waterproof shade white (39% polyester coated with 61% PVC), complete with fixing components for attached pergolas 369 cm deep with 2 extensions Kit telo impermeabile bianco (poliestere 39% spalmato di PVC 61%), completo di elementi di fissaggio per pergola addossata, di profondità cm 369 con 2 estensioni Kit toile imperméable blanche (39% polyester enduit de 61% PVC), éléments de fixation inclus pour pergola adossée de 369 cm de profondeur avec 2 extensions Bausatz aus wasserdichter weißer Plane (39% Polyester mit 61% PVC-Beschichtung), komplett mit Befestigungsmaterial für Anbaupergola mit 369 cm Tiefe und zwei Erweiterungen	CO369E2
Kit for waterproof shade white (39% polyester coated with 61% PVC), complete with fixing components for attached pergolas 393 cm deep Kit telo impermeabile bianco (poliestere 39% spalmato di PVC 61%), completo di elementi di fissaggio per pergola addossata, di profondità cm 393 Kit toile imperméable blanche (39% polyester enduit de 61% PVC), éléments de fixation inclus pour pergola adossée de 393 cm de profondeur Bausatz aus wasserdichter weißer Plane (39% Polyester mit 61% PVC-Beschichtung), komplett mit Befestigungsmaterial für Anbaupergola mit 393 cm Tiefe.	CO393
Kit for waterproof shade white (39% polyester coated with 61% PVC), complete with fixing components for attached pergolas 393 cm deep with 1 extensions Kit telo impermeabile bianco (poliestere 39% spalmato di PVC 61%), completo di elementi di fissaggio per pergola addossata, di profondità cm 393 con 1 estensione Kit toile imperméable blanche (39% polyester enduit de 61% PVC), éléments de fixation inclus pour pergola adossée de 393 cm de profondeur avec 1 extension Bausatz aus wasserdichter weißer Plane (39% Polyester mit 61% PVC-Beschichtung), komplett mit Befestigungsmaterial für Anbaupergola mit 393 cm Tiefe und einer Erweiterung	CO393E1
Kit for waterproof shade white (39% polyester coated with 61% PVC), complete with fixing components for attached pergolas 393 cm deep with 2 extensions Kit telo impermeabile bianco (poliestere 39% spalmato di PVC 61%), completo di elementi di fissaggio per pergola addossata, di profondità cm 393 con 2 estensioni Kit toile imperméable blanche (39% polyester enduit de 61% PVC), éléments de fixation inclus pour pergola adossée de 393 cm de profondeur avec 2 extensions Bausatz aus wasserdichter weißer Plane (39% Polyester mit 61% PVC-Beschichtung), komplett mit Befestigungsmaterial für Anbaupergola mit 393 cm Tiefe und zwei Erweiterungen	CO393E2
Kit for waterproof shade white (39% polyester coated with 61% PVC), complete with fixing components for freestanding pergolas 366 cm deep Kit telo impermeabile bianco (poliestere 39% spalmato di PVC 61%), completo di elementi di fissaggio per pergola autoportante, di profondità cm 366 Kit toile imperméable blanche (39% polyester enduit de 61% PVC), éléments de fixation inclus pour pergola autoportante de 366 cm de profondeur Bausatz aus wasserdichter weißer Plane (39% Polyester mit 61% PVC-Beschichtung), komplett mit Befestigungsmaterial für freistehende Pergola mit 366 cm Tiefe	COA366
Kit for waterproof shade white (39% polyester coated with 61% PVC), complete with fixing components for freestanding pergolas 366 cm deep with 1 extension Kit telo impermeabile bianco (poliestere 39% spalmato di PVC 61%), completo di elementi di fissaggio per pergola autoportante, di profondità cm 366 con 1 estensione Kit toile imperméable blanche (39% polyester enduit de 61% PVC), éléments de fixation inclus pour pergola autoportante de 366 cm de profondeur avec 1 extension Bausatz aus wasserdichter weißer Plane (39% Polyester mit 61% PVC-Beschichtung), komplett mit Befestigungsmaterial für Anbaupergola mit 366 cm Tiefe und einer Erweiterung	COA366E1
Kit for waterproof shade white (39% polyester coated with 61% PVC), complete with fixing components for freestanding pergolas 366 cm deep with 2 extensions Kit telo impermeabile bianco (poliestere 39% spalmato di PVC 61%), completo di elementi di fissaggio per pergola autoportante, di profondità cm 366 con 2 estensioni Kit toile imperméable blanche (39% polyester enduit de 61% PVC), éléments de fixation inclus pour pergola autoportante de 366 cm de profondeur avec 2 extensions Bausatz aus wasserdichter weißer Plane (39% Polyester mit 61% PVC-Beschichtung), komplett mit Befestigungsmaterial für Anbaupergola mit 366 cm Tiefe und zwei Erweiterungen	COA366E2
Kit for waterproof shade white (39% polyester coated with 61% PVC), complete with fixing components for freestanding pergolas 413 cm deep Kit telo impermeabile bianco (poliestere 39% spalmato di PVC 61%), completo di elementi di fissaggio per pergola autoportante, di profondità cm 413 Kit toile imperméable blanche (39% polyester enduit de 61% PVC), éléments de fixation inclus pour pergola autoportante de 413 cm de profondeur Bausatz aus wasserdichter weißer Plane (39% Polyester mit 61% PVC-Beschichtung), komplett mit Befestigungsmaterial für freistehende Pergola mit 413 cm Tiefe.	COA413
Kit for waterproof shade white (39% polyester coated with 61% PVC), complete with fixing components for freestanding pergolas 413 cm deep with 1 extension Kit telo impermeabile bianco (poliestere 39% spalmato di PVC 61%), completo di elementi di fissaggio per pergola autoportante, di profondità cm 413 con 1 estensione Kit toile imperméable blanche (39% polyester enduit de 61% PVC), éléments de fixation inclus pour pergola autoportante de 413 cm de profondeur avec 1 extension Bausatz aus wasserdichter weißer Plane (39% Polyester mit 61% PVC-Beschichtung), komplett mit Befestigungsmaterial für Anbaupergola mit 413 cm Tiefe und einer Erweiterung	COA413E1
Kit for waterproof shade white (39% polyester coated with 61% PVC), complete with fixing components for freestanding pergolas 413 cm deep with 2 extensions Kit telo impermeabile bianco (poliestere 39% spalmato di PVC 61%), completo di elementi di fissaggio per pergola autoportante, di profondità cm 413 con 2 estensioni Kit toile imperméable blanche (39% polyester enduit de 61% PVC), éléments de fixation inclus pour pergola autoportante de 413 cm de profondeur avec 2 extensions Bausatz aus wasserdichter weißer Plane (39% Polyester mit 61% PVC-Beschichtung), komplett mit Befestigungsmaterial für Anbaupergola mit 413 cm Tiefe und zwei Erweiterungen	COA413E2

→ Iron graphite / Ferro grafite / Fer graphite / Eisen grafitgrau

BAMBOO SHADES / STUOIE DI CANNE DI BAMBÙ / NATTES EN CANNES DE BAMBOU / BAMBUSMATTEN

Kit for bamboo shades made with bamboo canes of varying diameter (from 1 cm to 2 cm each) connected with a stainless steel wire. The kit includes fitting components / Kit di stuoie realizzate con canne di bambù di sezione variabile (da cm 1 a cm 2 ca.) e unite da un filo passante di acciaio inox. Il kit sono completi di elementi di fissaggio / Kit de nattes en cannes de bambou (de diamètre variant de 1 cm à 2 cm) reliées par un fil d'acier inoxydable. Eléments de fixations inclus dans le kit. / Satz Bambusmatten gefertigt aus Bambusstäben mit variablem Schnittdurchmesser (von 1 cm bis ca. 2 cm), verbunden mit Inox-Edelstahldraht, komplett mit Befestigungsmaterial

Structure / Strutture / Structures / Pergolen	
EE321 - EE369 - EE393 - EEA366 - EEA413	COBAM2
PE321 - EE321D - PE369 - EE369D PEA366 - EEA366D	COBAM3
PE393 - EE393D - PEA413 - EEA413D	COBAM4

ROLL SHADES / TELI SCORREVOLI / TOILES COULISSANTES / SONNENSCHUTZROLLO

Kit for adjustable shade in 100% acrylic, écru, complete with powder coated aluminium casing, colour graphite, spring retractable mechanism with tracks, for attached pergolas and extensions. / Kit telo regolabile di acrilico 100% colore écru, coprinullo di alluminio verniciato a polveri grafite, avvolgibile a molla e guide, per pergole addossate ed estensioni. / Kit toile réglable 100% acrylique, couleur écru, coffre pour rouleau en aluminium thermolaqué, couleur graphite, enrouleur à ressort et glissières inclus, pour pergolas adossées et extensions. / Bausatz für verstellbaren Sonnenschutz aus 100% ecrufarbenem Acryl, komplett mit pulverbeschichtetem Aluminiumkasten in der Farbe graphit. Federzugmechanismus mit Laufschiene für angebaute Pergolen und Erweiterungen.

Structure / Strutture / Structures / Pergolen	
PE321	CRE32
EE321	CRE32ES
EE321D	CRE32ED
PE369	CRE36
EE369	CRE36ES
EE369D	CRE36ED
PE393	CRE39
EE393	CRE39ES
EE393D	CRE39ED

FINISHES / FINITURE / FINITIONS / AUSFÜHRUNGEN

	Powder coated galvanized iron graphite Ferro zincato verniciato a polveri grafite Fer galvanisé enduit de poudre graphite Verzinktes, pulverbeschichtetes Eisen grafitgrau		100% acrylic fabric in white Tessuto acrilico 100% bianco Tissu 100% acrylique blanc Weißer Stoff aus 100% Acryl		Bamboo mat Stuoia bambù Natte de bambou Bambusmatte
---------------------------------------------------------------------------------------	-------------------------------------------------------------------------------------------------------------------------------------------------------------------------------------	---------------------------------------------------------------------------------------	---------------------------------------------------------------------------------------------------------------------------	---------------------------------------------------------------------------------------	--------------------------------------------------------------

→ Iron graphite / Ferro grafite / Fer graphite / Eisen grafitgrau

Complements
Technical
Sheets

Egadi
Jolly Cushions
Portofino
Rugs
Symi
Syros
Solare
Vases

Egadi

SITTING AND LOUNGE / SEDUTA E LOUNGE / ASSISE ET LOUNGE / SITZMÖBEL

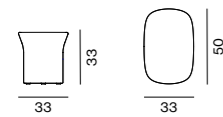

Sgabello basso in fibra smaltata
Low stool in enamelled fiber
Tabouret bas en fibre émaillée
Niedriger Hocker aus emailliertem Fiberglas

EGSGAGP Stone / Stone / Stone / Stone
EGSGAGTE Terracotta / Terracotta / Terracotta / Terracotta

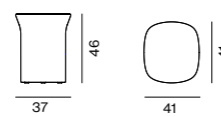

Sgabello alto in fibra smaltata
High stool in enamelled fiber
Tabouret haut en fibre émaillée
Hoher Hocker aus emailliertem Fiberglas

EGSGAPTO Dove / Dove / Dove / Dove
EGSGAPC Chocolate / Cioccolato / Chocolat / Schokolade

FINISHES / FINITURE / FINITIONS / AUSFÜHRUNGEN



Glazed cement Stone
Cemento smaltato Stone
Ciment émaillé Stone
Emaillierter Beton Stone



Glazed cement Dove
Cemento smaltato Dove
Ciment émaillé Dove
Emaillierter Beton Dove



Glazed cement Terracotta
Cemento smaltato Terracotta
Ciment émaillé Terracotta
Emaillierter Beton Terracotta



Glazed cement Chocolate
Cemento smaltato Cioccolato
Ciment émaillé Chocolat
Emaillierter Beton Schokolade

→ Glazed cement / Cemento smaltato / Ciment émaillé / Aluminium

Jolly Cushions

CUSHIONS / CUSCINI / COUSSINS / KISSEN

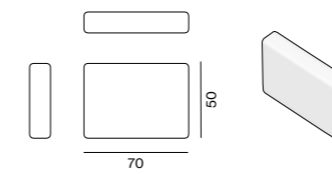

Removable cushion / Cuscino sfoderabile
Coussin déhoussable / Abziehbares Kissen
DECUR

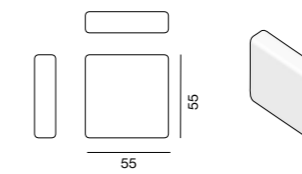

Removable cushion / Cuscino sfoderabile
Coussin déhoussable / Abziehbares Kissen
DECUG

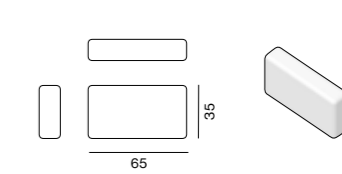

Removable cushion / Cuscino sfoderabile
Coussin déhoussable / Abziehbares Kissen
DECURP

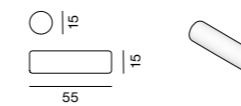

Removable cushion / Cuscino sfoderabile
Coussin déhoussable / Abziehbares Kissen
DECIL

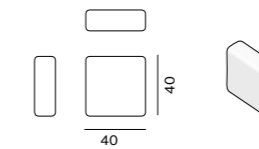

Set 4 removable cushion / Set 4 cuscini sfoderabili
Set 4 coussin déhoussable / Set mit 4 abziehbaren Kissen
DECUP

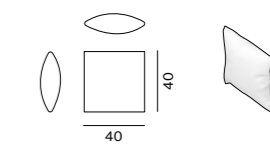

Set 5 removable cushion / Set 5 cuscini sfoderabili
Set 5 coussin déhoussable / Set mit 5 abziehbaren Kissen
DEJO

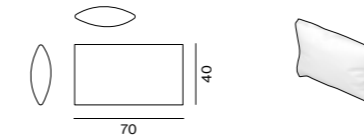

Removable cushion / Cuscino sfoderabili
Coussin déhoussable / Abziehbares Kissen
DEJOR

FINISHES / FINITURE / FINITIONS / AUSFÜHRUNGEN



Removable cushions Colour Collection pg. 305
Cuscini sfoderabili Colour Collection pg. 305
Coussins déhoussables Colour Collection pg. 305
Abziehbare Kissen aus der Kollektion Seite 305

→ Removable cushion / Cuscini sfoderabili / Coussin déhoussable / Abziehbare Kissen

Portofino

TABLE LAMP / LAMPADA DA TAVOLO / LAMPE DE TABLE / TISCHLAMPE



Table lamp in aluminum / Lampada da tavolo in alluminio
Lampe de table en aluminium / Tischlampe aus Aluminium

LANPOTC Terracotta / Terracotta
Terracotta / Terracotta

FINISHES / FINITURE / FINITIONS / AUSFÜHRUNGEN

 Aluminum terracotta
Alluminio terracotta
Aluminium terracotta
Aluminium terracotta

Pouf

POUF IN ROPE / POUF IN CORDA / POUF EN CORDE / HOCKER AUS SEIL

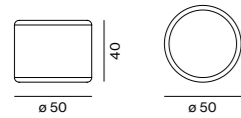

PU5040PGC
Light grey / Grigio chiaro / Gris clair / Hellgrau

PU5040PGS
Dark grey / Grigio scuro / Gris foncé / Dunkelgrau

FINISHES / FINITURE / FINITIONS / AUSFÜHRUNGEN

 Light grey polyolefin cord
Corda poliolefinica grigio chiaro
Cordon polyoléfine gris clair
Polyolefin-Seil Farbe Hellgrau

 Dark grey polyolefin cord
Corda poliolefinica grigio scuro
Cordon polyoléfine gris foncé
Polyolefin-Seil Farbe Dunkelgrau

Rugs

RUGS / TAPPETI / TAPIS / TEPPICHE

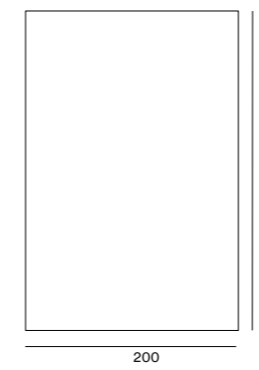

TAP32PJB
Ponza anthracite and ecru / Ponza antracite ecru
Ponza anthracite et écru / Ponza in Anthrazit und Ecru

TAP32PMA
Tropea striped in terracotta / Tropea a righe terracotta
Tropea à rayures terre cuite / Tropea mit terrakottafarbenen Streifen

FINISHES / FINITURE / FINITIONS / AUSFÜHRUNGEN

 Polypropylene cord anthracite and ecru
Corda polipropilene antracite ecru
Corde polypropylène anthracite et écru
Seil aus Polypropylen Anthrazit und Ecru

 Polypropylene cord stripes in terracotta
Corda polipropilene righe terracotta
Corde polypropylène rayures terre cuite
Seil aus Polypropylen terrakottafarbene Streifen

→ Polypropylene cord / Corda polipropilene / Corde polypropylène / Seil aus Polypropylen

Symi

TABLES / TAVOLI / TABLES / TISCHE

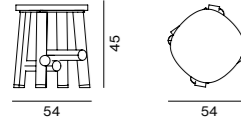

Low square table with teak base
Tavolo basso quadrato con base in teak
Table basse carrée avec base en teck
Quadratischer Couchtisch mit Teakholz-Gestell

COTBQUT Ceramic top with stone finish
Piano ceramica in finitura Stone
Plateau en céramique finition effet Stone
Keramikplatte in Stone

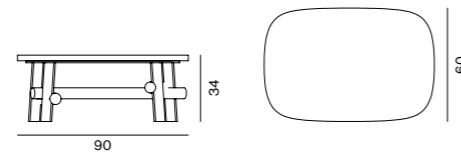

Low rectangular table with teak base
Tavolo basso rettangolare con base in teak
Table basse rectangulaire avec base en teck
Rechteckiger Couchtisch mit Teakholz-Gestell

COTBRET Ceramic top with Dove finish
Piano ceramica in finitura Dove
Plateau en céramique finition effet Dove
Keramikplatte in Dove

FINISHES / FINITURE / FINITIONS / AUSFÜHRUNGEN

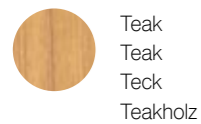

Teak
Teak
Teck
Teakholz



Ceramic Stone
Ceramica Stone
Céramique effet Stone
Keramik Stone



Ceramic Dove
Ceramica Dove
Céramique effet Dove
Keramik Dove

→ Teak / Teak / Teck / Teakholz
→ Ceramic / Ceramica / Céramique / Keramik

Syros

TABLES / TAVOLI / TABLES / TISCHE

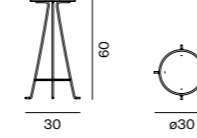

Occasional table in iron / Tavolo vuota tasche in ferro
table vide-poches en fer / Ablagetisch für Kleinteile aus Eisen

SYTASTTE Terracotta / Terracotta
Terracotta / Terracotta
SYTASTGR Graphite / Grafite
Graphite / Grafitgrau

FINISHES / FINITURE / FINITIONS / AUSFÜHRUNGEN



Powder coated galvanized iron graphite
Ferro zincato verniciato a polveri grafite
Fer galvanisé enduit de poudre graphite
Verzinktes, pulverbeschichtetes Eisen grafitgrau



Powder coated galvanized iron Terracotta
Ferro zincato verniciato a polveri Terracotta
Fer galvanisé enduit de poudre Terracotta
Verzinktes, pulverbeschichtetes Eisen Terracotta

→ Powder coated galvanized iron / Ferro zincato verniciato a polveri / Fer galvanisé enduit de poudre / Verzinktes, pulverbeschichtetes Eisen

Solare



LANTERNS / LANTERNE / LANTERNES / LATERNEN



LANATEBA Teak and graphite aluminium
Teak e alluminio grafite
Teck et aluminium graphite
Teakholz und grafitgraues Aluminium

LANITEBA Teak and stainless steel
Teak e acciaio inox
Teck et acier inoxydable
Teakholz und Edelstahl



LANTEQU Teak and graphite aluminium
Teak e alluminio grafite
Teck et aluminium graphite
Teakholz und grafitgraues Aluminium

FLOOR LAMPS / PIANTANE / LAMPADAIRES / BODENLEUCHTEN

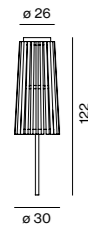

PITEAL Teak and graphite aluminium
Teak e alluminio grafite
Teck et aluminium graphite
Teakholz und grafitgraues Aluminium

PITEIN Teak and stainless steel
Teak e acciaio inox
Teck et acier inoxydable
Teakholz und Edelstahl

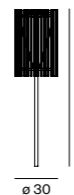

PIANTEQU Teak and graphite aluminium
Teak e alluminio grafite
Teck et aluminium graphite
Teakholz und grafitgraues Aluminium

Base not included, see on the opposite page / Basi non incluse vedi nella pagina accanto
Choix du pied de la lampe à la page suivante / Leuchtenfuß nicht enthalten, siehe nebenstehende Seite

- Teak slats / Listelli di Teak / Lattes de teck / Holzleisten aus Teak
- Aluminum / Alluminio / Aluminium / Aluminium
- Polyolefin cord / Corda poliolefinica / Corde en polyoléfine / Polyolefin Seil
- LED 13200mAh - 2700k - 600 lm

COMPLEMENTS / COMPLEMENTI / COMPLÉMENTS / ZUBEHÖR

Graphite aluminum base	Base in alluminio grafite	Base en aluminium graphite	Fuß aus Aluminium Farbe graphit	PIELA30FE
White aluminum base	Base in alluminio bianco	Base en aluminium blanc	Fuß aus Aluminium Farbe weiß	PIELA30FEB
Stainless steel base	Base in acciaio inox	Base en acier inoxydable	Fuß aus Edelstahl	PIELA30IN
Spike in stainless steel	Picca in acciaio inox	Pique en i acier inoxydable	Erdspieß aus Edelstahl	PICPIASO
Bracket for anchoring to cement	Staffa per ancoraggio al cemento	Support pour ancrage au béton	Halterung zur Verankerung in Beton	PIECESO

FINISHES / FINITURE / FINITIONS / AUSFÜHRUNGEN

 Aluminum graphite
Alluminio grafite
Aluminium graphite
Aluminium grafitgrau

 Stainless steel
Acciaio inox
Acier inoxydable
Fuß aus Edelstahl

 Aluminum white
Alluminio bianco
Aluminium blanc
Aluminium weiß

 Teak slats
Listelli di Teak
Lattes de Teck
Holzleisten aus Teak

- Teak slats / Listelli di Teak / Lattes de teck / Holzleisten aus Teak
- Aluminum / Alluminio / Aluminium / Aluminium
- Polyolefin cord / Corda poliolefinica / Corde en polyoléfine / Polyolefin-Seil
- LED 13200mAh - 2700k - 600 lm

Vases

VASE IN CONCRETE AND MARBLE / VASO IN CEMENTO E MARMO / VASE EN BÉTON ET MARBRE / PFLANZGEFÄß AUS BETON UND MARMOR

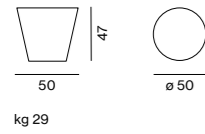

VAA5047TC

Terracotta / Terracotta
Terracotta / Terracotta

VAA5047GS

Dark grey / Grigio scuro
Gris foncé / Dunkelgrau

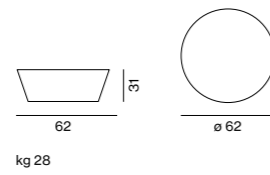

VAC6231TC

Terracotta / Terracotta
Terracotta / Terracotta

VAC6231GS

Dark grey / Grigio scuro
Gris foncé / Dunkelgrau

FINISHES / FINITURE / FINITIONS / AUSFÜHRUNGEN



Concrete and marble terracotta
Cemento e marmo terracotta
Béton et marbre terracotta
Beton und Marmor terracotta



Concrete and marble dark grey
Cemento e marmo grigio scuro
Béton et marbre gris foncé
Beton und Marmor Dunkelgrau

Concrete and marble / Cemento e marmo / Béton et marbre / Beton und Marmor

→ Concrete and marble / Cemento e marmo / Béton et marbre / Beton und Marmor

Protection Covers

Covers for AGORÀ	
Sofa	C237T
Armchair	C130T
Lounge and End modules	C162T
Corner module	C10668T
Backrest module	C74106T
Sunlounger	C216T
Square coffee table	C106T
Island	C208T
Covers for ARIETE	
Armchair	C130T
Sofa	C212T
Covers for AURORA	
Armchair Art. MORPOS	C100T
Sofa Art. MORDIS	C196T
Chair	C60T
Armchair Art. AUPOLG	C69T
Sofa Art. AUDIG	C140T
Sunlounger	C216T
Covers for CAPRI	
Small armchairs	C69T
Covers for C'EST LA VIE	
Corner / Backrest Module	C80T
Sofa 2 seats	C162T
Sofa 3 seats	C262T
Sunlounger	C216T
Double sunlounger	C200145T
Rectangular table extractable tabletops	C162T
Square table	C150QT
Rectangular coffee table	C8268T
Covers for CHELSEA	
Armchair	C82T
Sofa 144 cm	C162T
Sofa 209 cm	C212T
Sunlounger	C216T
Chairs and small armchairs SEBRI BRISE	C69T
Sofa 155 cm	C162T
Sofa 183 cm	C186T
Table 165 x 90 cm	C180T
Table 217 x 102 cm	C237T
Table 80 x 80 cm	C80T
Table 140 x 80 cm	C162T
Square coffee table 50 x 50 cm	C5050T
Square coffee table 80 x 80 cm	C106T
Covers for CORA	
Chair	C69T
Armchair	C80T
Sofa	C162T
Sunlounger	C216T
Double sunlounger	C200145T
Island	C165T
Round table	C150QT

Covers for COSETTE	
Deckchair	C20100T
Small armchair	C69T
Table 230 x 100 cm	C237T
Covers for DAVOS	
Armchair / End module	C130T
Backrest / Corner module	C10668T
Lounge module	C162T
Sunlounger	C216T
Pouf / Rectangular coffee table module	C106T
Covers for GINGER	
Small armchair	C69T
Covers for IGEEA	
Chair	C20100T
Chair with armrests	C69T
Armchair	C82T
Sofa 2 seats	C162T
Sofa 3 seats	C262T
Pouf	C106T
Sunlounger	C216T
Covers for LIPARI	
Umbrella Art. RE34A	C01T
Umbrella Art. QU98A	C02T
Covers for LUCE	
Armchair	C7272T
Sofa 2 seats	C15083T
Sofa 3 seats	C186T
Chair and small armchair	C64T
Stool	C6258T
Sunlounger	C216T
Covers for OLIMPIA	
Armchair	C82T
Sofa 2 seats	C162T
Sofa 3 seats	C212T
Rectangular coffee table	C10070T
Covers for PEVERO	
Armchair	C64T
Rectangular coffee table	C5050T
Covers for SALO	
Armchair	C100T
Sofa 2 seats	C162T
Sofa 3 seats	C262T
Sunlounger	C216T
Chair	C64T
Stool with backrest	C6258T
Tall stool	C60T
Low stool	C5050T
Covers for SYMI	
Rectangular coffee table	C10070T
Square coffee table	C5050T

Covers for SYNTHESIS	
Chair	C60T
Small armchair	C60T
Small armchair low	C6069T
Armchair Art. SYPO	C8093T
Deckchair Art. SDRASY	C6586T
Lounge armchair Art. POLOS Y	C6586T
Sofa Art. SYDI - SYLD	C212T
Pouf SYPU	C106T
Sofa Art. SYDIG	C262T
Lounge, Backrest and End modules	C162T
Sunlounger	C216T
Table Art. TASYQU - SYTARO	C150QT
Table 230 x 100 cm	C237T
Table Art. TASYQB	C8093T
Table Art. TAQULESY	C80T
Coffee table Art. SYTABQM	C5050T
Coffee table Art. SYTABRM - SYTABR	C15585T
Covers for TITANIC	
Chaise longue	C20100T
Covers for TOSCANA	
Armchair	C82T
Sofa	C162T
Chair and small armchair	C20100T
Covers for TREBLE	
Armchair	C80T
Sofa, lounge and corner modules	C15083T
Covers for VERSILIA	
Round table	C150QT
Rectangular table	C180T
Covers for WELCOME	
Armchair	C10668T
Rectangular coffee table	C15585T
Square coffee table	C5555T
Covers for WILLIAM	
Chair	C20100T

ACCESSORIES / ACCESSORI ACCESSOIRES / ZUBEHÖR

Anti-slip fabric for teak furniture 200 x 140 cm	TESANT
Tessuto antiscivolo per arredi in Teak 200 x 140 cm	
Tissu antidérapant pour meubles en teak 200 x 140 cm	
Rutschhemmender Stoff für Teakholzmöbel, 200x 140 cm	

Cleaning kit & Paint

A kit is available for cleaning synthetic fibre and consists of a special non-foaming detergent that removes dirt and restores the appearance of the fibre, as well as a protective spray that maintains the furniture longer, nourishes the plasticisers and maintains the flexibility of the fibre. The UV filter keeps the look unchanged and extends its life over time, helping to prevent stains. This compound can also be used on iron, stone, fabric rope and aluminium to clean and maintain products properly. Another product that ensures long life for outdoor wooden furniture is Teak Oil, a teak-coloured impregnating agent capable of moisturising and restoring the furniture's original golden colour.

Per la pulizia della fibra sintetica è disponibile un Kit composto da un detergente speciale non schiumogeno che rimuove lo sporco e ripristina l'aspetto della fibra, e da uno spray di protezione che mantiene i mobili più a lungo, alimenta i plastificanti e mantiene la flessibilità della fibra. Il filtro UV mantiene inalterato l'aspetto e ne prolunga la durata nel tempo aiutando a prevenire le macchie. Questo composto può essere anche usato su ferro, pietra, corda in tessuto e alluminio per pulire e mantenere al meglio i prodotti. Altro prodotto per garantire lunga vita ai mobili da esterno in legno è l'Olio di Teak, impregnante color teak in grado di idratare e restituire l'originale colorazione dorata ai mobili.

Pour le nettoyage de la fibre synthétique, nous proposons un Kit composé d'un détergent spécial non moussant qui élimine la saleté et répare l'aspect de la fibre, et d'un spray de protection qui préserve durablement la beauté des meubles, nourrit les revêtements en plastique et entretient la flexibilité de la fibre. Le filtre UV permet de conserver son apparence et prolonge sa durée de vie tout en protégeant des taches. Ce composé, qui peut également être utilisé sur le fer, la pierre, la corde en tissu et l'aluminium, est idéal pour nettoyer et optimiser l'entretien des meubles. Un autre produit permet de préserver la beauté des meubles d'extérieur : il s'agit de l'Huile de Teck, un agent d'imprégnation de couleur teak qui hydrate et restitue leur couleur dorée originale aux meubles.

Zur Pflege der Kunstfaser ist ein Reinigungsset verfügbar. Dieses Set besteht aus einem nicht schäumenden Spezialreiniger, der Schmutz entfernt und die Faser wieder in ihrem ursprünglichen Erscheinungsbild erstrahlen lässt und aus einem Schutzspray, das die Möbelstücke pflegt und die Flexibilität der Faser erhält. Auch der enthaltene UV-Filter wirkt sich positiv auf das Erscheinungsbild aus, indem er hilft Flecken vorzubeugen und somit die Lebensdauer der Möbelstücke zu verlängern. Dieses Mittel kann auf Eisen, Stein, Stoffseilen und Aluminium angewandt werden, um damit sämtliche Produkte optimal zu reinigen und zu pflegen. Ein weiteres Produkt für die Langlebigkeit von Holzmöbeln im Außenbereich ist Teaköl, ein Imprägniermittel für Holz, das diesem Feuchtigkeit zuführt und Teakholz seine ursprüngliche goldene Farbe zurückgibt.



OLTEAK05



Transparent paint 2,5 lt

UCNS
Dark walnut / Noce scuro
Noyer foncé / Nussbaum

UCP
Teak / Teak / Teck / Teak

Paint 2,5 lt

UCB
White / Bianco / Blanc / Weiß

UCG
Graphite / Grafite / Graphite / Grafitgrau

UCV
English green / Verde inglese
Vert anglais / Englisch Grün



KITCHARETEAK



KITCHARESURF



NAGIMP1L

Impregnating oil for wood Nagi collection
Olio impregnante per legno collezione Nagi
Bidon d'huile de 1 litre pour bois collection Nagi
Imprägnieröl für Holz für die Kollektion Nagi

Wood

TEAK / TEAK / TECK



En -

We manufacture our teak products in Indonesia, near controlled regrowth plantations which are protected and guaranteed by certifications, a precise choice to reduce CO2 emissions. Each tree is carefully selected before being sent for processing, in total compliance with eco-sustainability procedures. The teak wood in warm shades used by Unopiù is sourced exclusively from controlled regrowth plantations in accordance with strict reforestation processes and is grade A only, which is the highest grade in terms of quality, by selecting the middle part of the trunk to ensure durability and dimensional stability. Naturally rich in mineral salts and oils, it is particularly resistant to atmospheric conditions such as sun, rain and sea salt, as well as being naturally resistant to parasites, making it especially suitable for outdoor use.

MAINTENANCE

Teak is a very valuable wood that by its very nature has exceptional weather resistant characteristics. Unopiù uses it by leaving it natural, without any treatment; therefore, colour variations between one element and another are to be considered normal. Any cracks that may occur on the surface are not to be considered a defect, and their visibility will vary depending on changes in temperature and humidity. Before using it for the first time, Unopiù recommends leaving the furniture in the open air for 24-48 hours, helping the reactivation of the fibres which, by nature, will expel the excess natural oil produced during storage. It is then advisable to wipe the entire surface with a damp cloth made of natural fibres such as cotton or jute. It is good practice to repeat this process periodically. When left exposed to the elements, it tends to turn silvery-grey in colour; this phenomenon is testimony to the natural state of the wood that lives and reacts to the external environment with a maturation/oxidation process that in no way alters the structural integrity of the product. The honey shade can be maintained or restored by using the specific maintenance products that Unopiù offers its customers.

It -

Realizziamo i nostri prodotti in teak in Indonesia, vicino a piantagioni a ricrescita controllata, protette e garantite da certificazioni, una scelta precisa per ridurre le emissioni di CO2. Ogni albero viene accuratamente selezionato prima di essere destinato alla trasformazione, nel totale rispetto delle procedure di ecosostenibilità. Il legno di teak utilizzato da Unopiù, dalle calde sfumature di colore, proviene esclusivamente da piantagioni a ricrescita controllata nel rispetto dei rigidi processi di riforestazione ed è solo di grado A - il grado più elevato in termini di qualità - selezionandone la parte centrale del tronco, per garantire durabilità e stabilità dimensionale. Ricco per natura, di sali minerali ed oli, è particolarmente resistente agli agenti atmosferici quali sole, pioggia, salsedine, oltre a resistere per natura all'attacco di parassiti, per questo è particolarmente adatto all'outdoor.

MANUTENZIONE

Il teak è un legno molto pregiato che per natura ha caratteristiche di eccezionale resistenza agli agenti atmosferici. Unopiù lo utilizza lasciandolo naturale, senza alcun trattamento; pertanto, sono da considerare del tutto nella norma variazioni di colore tra un elemento e l'altro. Non sono da considerare un difetto, eventuali fessurazioni che potrebbero verificarsi in superficie, esse saranno più visibili o meno, in base ai cambiamenti di temperatura e in base al tasso di umidità. Prima del primo utilizzo, Unopiù consiglia di lasciare il mobile all'aria aperta per 24-48 ore, favorendo la riattivazione delle fibre che per natura, espelleranno l'eccesso di olio naturale, prodotto durante l'immagazzinamento, e successivamente, di passare su tutta la superficie, con un panno umido in fibra naturale quali cotone o juta. È buona abitudine, ripetere tale operazione periodicamente. Lasciato esposto agli agenti atmosferici tende ad assumere una colorazione argentea tendente al grigio; tale fenomeno è la testimonianza della naturalità del legno che vive e reagisce all'ambiente esterno con un processo di maturazione/ossidazione che non altera in nessuno modo l'integrità strutturale del prodotto. La tonalità miele potrà essere mantenuta o ripristinata grazie ai prodotti specifici per la manutenzione che Unopiù propone ai suoi clienti.

MAHOGANY / MOGANO / ACAJOU



En -

This high-quality wood is popular due to its fine grain, elegance and finish. Mahogany is a wood that comes in warm red to dark brown tones and has a tendency to darken over time, a distinctive and elegant feature. With a very pleasant appearance, in the past it was used for elegant English drawing rooms as well as vessels and fleets. It is easy to process, enabling precise and refined details to be created. Unopiù treats mahogany with a special polishing process that enhances its elegance and makes it very pleasant to the touch and aesthetically appealing.

MAINTENANCE

As far as cleaning is concerned, there are certain things to bear in mind: if the mahogany is processed and has hollows, a soft bristle brush can be used gently to clean these thoroughly. Unopiù then suggests wringing out a soft cloth, first soaked in a solution of lukewarm water with a mild liquid soap, and wiping it all over the wood. Once all the surfaces have been cleaned, dry them immediately and thoroughly. Unopiù recommends that mahogany products are used under a covered exterior, such as a pergola.

It -

Un legno pregiato, apprezzato per la grana fine, l'eleganza e la finitura. Il mogano è un legno che offre calde tonalità dal rosso al marrone scuro e ha la tendenza a scurirsi nel tempo, un tratto distintivo ed elegante. Esteticamente molto gradevole, in passato era destinato a eleganti salotti inglesi come pure a vascelli e flotte. La facilità di lavorazione permette di realizzare dettagli precisi e raffinati. Unopiù tratta il mogano con uno speciale processo di lucidatura che ne esalta l'eleganza e che lo rende tanto gradevole al tatto e alla vista.

MANUTENZIONE

Per quanto riguarda la pulizia, ci sono delle accortezze da tenere a mente: se il mogano è lavorato e presenta parti incave, per pulirle in profondità basta usare con delicatezza un pennello a setole morbide. Unopiù suggerisce poi di strizzare un panno morbido, prima bagnato in una soluzione di acqua tiepida con un sapone liquido neutro, e passarlo sul legno in ogni sua parte. Una volta pulite tutte le superfici, asciugarle subito e accuratamente. Unopiù consiglia l'utilizzo dei prodotti in mogano sotto un esterno coperto (pergole).

PINE / PINO / PIN



En -

Unopiù uses top-quality Nordic pine for its structures, a material which is particularly resistant and durable due to the cold climate in which it grows. Unopiù's Nordic pine effectively undergoes a vacuum pressure impregnation process and is then treated with specific plant oil-based products, which strengthen its resistance to weathering. Thanks to these treatments, which also protect it from attacks by insects, mould and fungi, it is able to maintain its attractive appearance even in harsh atmospheric conditions. The life of properly impregnated and regularly maintained wood is almost unlimited.

MAINTENANCE

Unopiù's Nordic pine undergoes effective preliminary impregnation processes, providing the material surface with an adequate protective layer, which can be renewed using our specific maintenance products.

It -

Unopiù utilizza, per realizzare le proprie strutture, pino nordico di prima qualità, materiale di particolare resistenza e durata conferitogli dal clima freddo in cui cresce. Il pino nordico di Unopiù, viene sottoposto con efficacia a un processo di impregnazione sottovuoto, successivamente viene trattato con prodotti specifici a base di olio vegetale, che ne rafforzano la resistenza agli agenti atmosferici. Grazie a questi trattamenti, che lo preservano anche da attacchi di insetti, muffe, funghi, è in grado di mantenere inalterato il suo aspetto gradevole anche di fronte all'usura degli agenti atmosferici. La durata di un buon legno impregnato e regolarmente mantenuto è pressoché illimitata.

MANUTENZIONE

Il pino nordico di Unopiù viene sottoposto ad efficaci processi di impregnazione preliminare, che forniscono alla superficie del materiale, un adeguato strato protettivo, che è possibile rinnovare, utilizzando i nostri prodotti specifici per la manutenzione.

Metal

IRON / FERRO / FER



En -

Iron is one of the most common elements on the planet and is characterised by high resistance to harsh weather conditions. It is the material that belongs to Unopiù's heritage and it features in some of its timelessly stylish collections. The ductility of iron lends itself very well to artisanal or industrial processing in multiple morphologies, being malleable both for creations with linear and minimalist aesthetics and for more detailed and creative products. The Unopiù wrought iron is entirely handmade by skilled craftsmen using old-fashioned techniques and is galvanised to achieve an even-looking and resistant surface. The galvanising process is commonly used to protect iron from atmospheric and water corrosion. The Unopiù wrought iron outdoor furniture combines aesthetics, durability and practicality, as it does not have to be stored inside during the winter season.

MAINTENANCE

Wash with natural mild soap, wipe with Vaseline oil once dry. In order to avoid water stagnation, when it rains it is advisable to leave it to dry in the sun before covering it.

It -

Il ferro è uno degli elementi più comuni sul pianeta ed è caratterizzato da un'elevata resistenza a condizioni atmosferiche sfavorevoli. È il materiale che appartiene all'heritage di Unopiù e con il quale ha realizzato alcune delle sue collezioni dallo stile senza tempo. La duttilità del ferro si presta egregiamente alla lavorazione artigianale o industriale in molteplici morfologie, risultando malleabile sia per realizzazioni dall'estetica lineare ed essenziale, sia per prodotti più articolati e creativi. Il ferro battuto di Unopiù è interamente lavorato a mano da abili artigiani con le tecniche di una volta e viene zincato per ottenere una superficie omogenea e resistente. Comunemente, il processo di zincatura è utilizzato per proteggere il ferro dalla corrosione atmosferica e dell'acqua. Gli arredi da esterni in ferro battuto di Unopiù abbinano estetica, durabilità e praticità perché non devono necessariamente essere riposti all'interno durante stagione invernale.

MANUTENZIONE

Lavare con sapone neutro naturale, una volta asciugato passare olio di vasellina. Al fine di evitare ristagni d'acqua, quando piove è consigliabile farlo asciugare al sole prima di coprirlo.

STAINLESS STEEL / ACCIAIO INOX / ACIER INOXYDABLE



En -

Steel is an alloy consisting mainly of iron and carbon. Stainless steel is a durable stainless material with exceptional technical and aesthetic properties. High corrosion resistance makes it more long-lasting and reliable over time. The contemporary appeal of steel is perfectly matched by its extreme versatility, making it a superior material with an almost infinite number of uses. Unopiù chooses steel as the go-to material for many of its outdoor products, taking advantage of its exceptional characteristics to create durable, high-quality furniture in a refined version, successfully enhancing a material that is considered industrial by combining it with elegantly designed pieces. Unopiù uses AISI304 stainless steel, a fine material with high resistance in harsh environments, especially to corrosion and all weathering.

MAINTENANCE

It is an exceptional material, able to withstand weathering while maintaining its appeal over time. To maintain it, it must be cleaned and polished with specific products and when unused for prolonged periods and exposed to UV rays, Unopiù recommends storing the furniture in a sheltered place.

It -

L'acciaio è una lega composta principalmente da ferro e carbonio. L'acciaio inox è un materiale inossidabile dalle eccezionali caratteristiche tecniche, estetiche e dalle straordinarie proprietà di durata. L'alta resistenza alla corrosione lo rende maggiormente duraturo e affidabile nel tempo. Il fascino contemporaneo dell'acciaio si sposa perfettamente a una estrema versatilità, rendendolo un materiale superiore dagli usi pressoché infiniti. L'acciaio è il materiale d'elezione per molti prodotti per outdoor di Unopiù, che sfrutta le eccezionali caratteristiche dell'acciaio per creare arredi durevoli e di alta qualità in una versione raffinata, valorizzando con successo un materiale considerato industriale legandolo a oggetti dall'elegante design. Unopiù utilizza acciaio inox AISI304, materiale nobile dalla elevata resistenza in ambienti aggressivi, in particolare alla corrosione e a tutti gli agenti atmosferici.

MANUTENZIONE

È un materiale eccezionale, capace di resistere alle sollecitazioni degli agenti atmosferici mantenendo nel tempo il suo appeal. Per mantenerlo deve essere pulito e lucidato con prodotti specifici e in caso di periodi prolungati di inutilizzo con esposizione ai raggi UV, Unopiù consiglia di riporre gli arredi in un luogo riparato.

Aluminium

TERRACOTTA



En -

Aluminium is a lightweight and strong metal which is one of the most naturally occurring elements. It has a high level of corrosion resistance, allowing the products to have excellent durability. Its high malleability and ductility and extreme lightness make it a very supple metal. In addition to being easy to handle and process, its versatility makes it suitable for producing various kinds of objects, from tables and lamps to chairs and armchairs. Aluminium is environmentally friendly, being an infinitely recyclable material that can be transformed and reintroduced into the production cycle, taking on a new aesthetic and functional value each time while being kind to the environment. The Unopiù aluminium alloy furniture, which is lightweight and easy to move despite its elegance, is treated with a coating that involves the electrostatic application of thermosetting polyester powders, with subsequent polymerisation in an oven at temperatures of 180-200°.

MAINTENANCE

Wash with natural mild soap, wipe with Vaseline oil once dry. In order to avoid water stagnation, when it rains it is advisable to leave it to dry in the sun before covering it.

It -

L'alluminio è un metallo leggero e robusto, uno degli elementi più presenti in natura. Ha un elevato livello di resistenza alla corrosione, il che consente ai prodotti di avere un'eccellente durata. L'ottima malleabilità e duttilità e l'estrema leggerezza lo rendono un metallo altamente plastico. Oltre a essere maneggevole e di facile lavorazione – la sua versatilità lo rende adatto alla produzione di oggetti di diversa natura, da tavoli a lampade fino a sedie e poltrone – l'alluminio è rispettoso dell'ambiente, essendo un materiale infinitamente riciclabile che può essere trasformato e reimmesso all'interno del ciclo produttivo, assumendo ogni volta una nuova valenza estetica e funzionale nel rispetto dell'ambiente. I mobili in lega di alluminio di Unopiù, leggeri e pratici da spostare pur nella loro eleganza, vengono trattati con una verniciatura che prevede l'applicazione elettrostatica di polveri poliestere termoindurenti, con successiva polimerizzazione in forno a temperature di 180-200°.

MANUTENZIONE

Lavare con sapone neutro naturale, una volta asciugato passare olio di vasellina. Al fine di evitare ristagni d'acqua, quando piove è consigliabile farlo asciugare al sole prima di coprirlo.

SALVIA



SABBIA

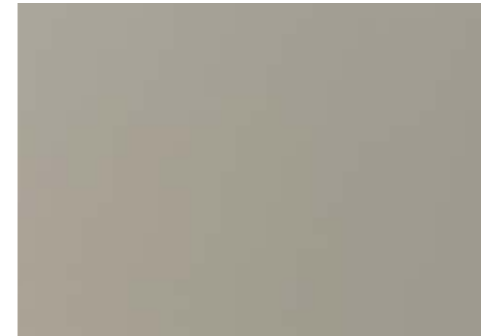

GRAFITE



CIOCCOLATO

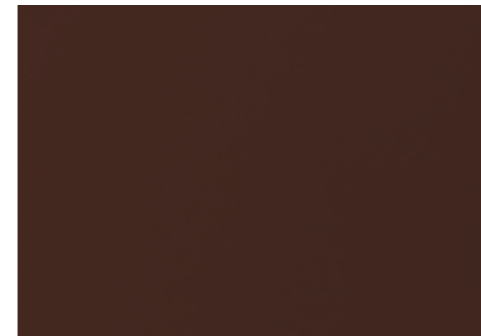

Synthetic Fibre

WAPROLACE®



En ~

WaProLace® is a state-of-the-art synthetic material, registered by Unopiù and designed to withstand the challenges of outdoor environments - such as the attack of climatic agents, salt, chlorine, mould, parasites, fungi, bacteria and sunscreens - while maintaining its colour and characteristics and perfectly reproducing the warm, genuine appearance of natural fibre texture. WaProLace® is a recyclable and biodegradable material that is lightweight, smooth to the touch, impermeable to liquids, stain-resistant, antistatic and easy to clean; it is resistant to temperature variations and can withstand harsh winter weather. WaProLace® synthetic fibre is made of polyethylene, treated to make it anti-oxidising, UV-resistant and fireproof. Unopiù's decision to use WaProLace® in the creation of many of its outdoor furniture lines reflects the company's commitment to creating weather-resistant furniture. Both aesthetically and in terms of performance, the remarkable features of this synthetic fibre are guaranteed, making WaProLace® a high-quality and sustainable material.

MAINTENANCE

WaProLace® fibre can be washed with water and mild soap, and rinsed well. Once dry, it can be treated with a special product that revives the colour and protects the fibres. Everything you need is contained in the Unopiù cleaning kit.

It ~

WaProLace® è un materiale sintetico di ultima generazione, registrato da Unopiù e progettato per resistere alle sfide degli ambienti outdoor – come l'attacco di agenti climatici, salsedine, cloro, muffe, parassiti, funghi, batteri e creme solari – mantenendo sempre inalterati colore e caratteristiche e riproducendo perfettamente l'aspetto caldo e genuino della tessitura delle fibre naturali. WaProLace® è un materiale riciclabile e biodegradabile, leggero, liscio al tatto, impermeabile ai liquidi, antimacchia, antistatico e semplice da pulire; è resistente alle variazioni di temperatura e può sopportare un clima invernale rigido. La fibra sintetica WaProLace® è realizzata in polietilene, trattato per renderlo antiossidante, resistente ai raggi UV ed ignifugo. La decisione di Unopiù di utilizzare WaProLace® nella creazione di molte delle sue linee di arredo per esterni rispecchia l'impegno dell'azienda nel creare mobili resistenti agli agenti atmosferici. Sia a livello estetico sia prestazionale, le notevoli prerogative di questa fibra sintetica sono garantite, rendendo WaProLace® un materiale sostenibile di alta qualità ed eleganza d'uso.

MANUTENZIONE

La fibra WaProLace® può essere lavata con acqua e sapone neutro, e ben risciacquata, una volta asciugata può essere trattata con apposito prodotto che ravviva il colore e protegge le fibre. Tutto il necessario è contenuto nel kit di pulizia Unopiù.

Rope

POLYOLEFIN ROPE / CORDA POLIOLEFINICA / CORDE POLYOLÉFINE



En ~

Compared to any other man-made fibre, including polyester and nylon, polyolefin rope is more resistant to chemicals - at room temperature, this rope has a high resistance to the effects of alkaline acids. Polyolefin rope is resistant to fungi and bacteria and is well tolerated by living tissue, as long as it does not contain any special stabilisers or additives that - if they were to transpire to the outside - could alter its strength properties. The polyolefin rope chosen by Unopiù is solution-dyed using pigments purchased from a few selected, highly qualified suppliers: this dyeing process guarantees not only excellent colour uniformity but also very high resistance. Polyolefin rope perfectly combines the typical characteristics of the finest natural fabrics, such as their soft, pleasant feel and practicality, with the strength of a synthetic fibre.

MAINTENANCE

Woven polyolefin rope is a material that provides excellent performance in outdoor environments due to its practicality and softness, which is typical of natural fabrics, combined with the extreme resistance resulting from the use of a synthetic material. To keep its attractive appearance over time, it does not require any maintenance treatment, but if desired, it can be washed periodically to remove dirt and dust that may get stuck in the weave. To avoid damaging the material during this process, Unopiù suggests using lukewarm clean water (max. 30°), a mild detergent such as Marseille soap or one for delicate fabrics (never bleach or ammonia), and a soft synthetic brush. After washing, Unopiù recommends drying the rope in the shade, possibly in the open air but away from heat sources.

It ~

Rispetto a qualsiasi altra fibra artificiale, inclusi poliestere e nylon, la corda poliolefinica è maggiormente resistente agli agenti chimici – a temperatura ambiente, questa corda presenta un'elevata resistenza agli effetti degli acidi alcalini. La corda in polipropilene è resistente a funghi e batteri ed è ben tollerata dai tessuti vivi, purché non contenga stabilizzanti o additivi particolari che – se dovessero traspirare verso l'esterno – potrebbero alterarne le proprietà di resistenza. La corda poliolefinica scelta da Unopiù è tinta in massa utilizzando pigmenti acquistati da pochi fornitori selezionati, altamente qualificati: questo processo di tintura garantisce non solo un'ottima uniformità del colore ma anche una resistenza molto elevata. La corda poliolefinica combina perfettamente le caratteristiche tipiche dei tessuti naturali più pregiati, come morbidezza, piacevolezza al tatto e praticità, e la resistenza di una fibra sintetica.

MANUTENZIONE

La corda poliolefinica intrecciata è un materiale che offre ottime prestazioni negli ambienti esterni grazie alla sua praticità e morbidezza, tipiche dei tessuti naturali, unite all'estrema resistenza dovuta all'utilizzo di un materiale sintetico. Per mantenersi bella nel tempo non necessita di alcun trattamento di manutenzione, ma se lo si desidera si può provvedere a lavarla periodicamente per eliminare sporco e polvere che possono insinuarsi nell'intreccio. Per non danneggiare il materiale durante questa operazione, Unopiù suggerisce di utilizzare acqua pulita tiepida (max 30°), un detergente neutro come il sapone di Marsiglia o uno per i tessuti delicati (mai candeggina o ammoniaca), e infine una spazzola morbida sintetica. Una volta terminato il lavaggio, Unopiù consiglia di far asciugare la corda all'ombra, possibilmente all'aria aperta ma lontano da fonti di calore.

Gres

En -

Porcelain stoneware is the ideal choice for those seeking durability, high performance, and elegant design. Thanks to its hardness and resistance to chemical agents, it is perfect for any environment, both indoors and outdoors, and guarantees long-lasting performance even in high-traffic areas, such as contract spaces. It is resistant to fungi, bacteria, and does not retain dust or dirt, making cleaning easier.

MAINTENANCE

For everyday cleaning, simply use a neutral detergent with lukewarm water, avoiding harsh products such as bleach or ammonia. For stubborn stains, use a non-abrasive sponge and, if necessary, a specific stain remover, avoiding steel wool. Rinse the surface quickly to remove any residue from liquids or caustic substances. Avoid products containing hydrofluoric acid and/or its derivatives to preserve the surface. With proper care, porcelain stoneware maintains its features over time, offering quality and longevity.

It -

Il gres porcellanato è la scelta ideale per chi cerca resistenza, prestazioni elevate e design elegante. Grazie alla sua durezza e resistenza agli agenti chimici, è perfetto per ogni ambiente, interno ed esterno, e garantisce lunga durata anche in ambienti ad alto traffico, come quelli contract. È resistente a funghi, batteri e non trattiene polvere o sporco, facilitando la pulizia.

MANUTENZIONE

Per la pulizia quotidiana, basta un detergente neutro con acqua tiepida, evitando prodotti aggressivi come candeggina o ammoniaca. Per macchie persistenti, utilizzare una spugna poco abrasiva e, se necessario, un prodotto smacchiante specifico, evitando pagliette d'acciaio. Risciacquare rapidamente la superficie per rimuovere residui di liquidi o sostanze caustiche.

Evitare prodotti contenenti acido fluoridrico e/o suoi derivati per preservare la superficie. Con la giusta cura, il gres porcellanato mantiene intatte le sue caratteristiche nel tempo, offrendo qualità e longevità.

PIETRA

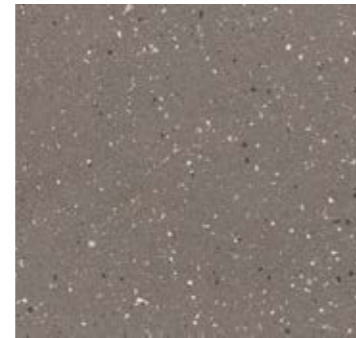

TERRACOTTA



DESERTO



Fiberstone

En -

Fiberstone is ideal for those seeking contemporary design, visual lightness, and long-lasting durability. Thanks to the combination of polyresin, fiberglass, and crushed stone, it provides a solid and sturdy structure. The handcrafted process, including manual sanding and finishing, ensures a refined and carefully detailed appearance.

MAINTENANCE

For daily cleaning, use a neutral liquid detergent or mild soap with water, applying with a soft-bristle brush and gentle motions to preserve the sealant. Avoid citrus-based cleaners, harsh solvents, bleach, ammonia, or industrial products.

Fiberstone can be damaged if exposed to standing water or mud in freezing temperatures. In areas with prolonged frost, it is recommended to cover or store the products indoors during winter months.

With proper care, fiberstone maintains its aesthetic and structural characteristics over time, offering lasting quality and durability.

It -

Il fiberstone è ideale per chi cerca design contemporaneo, leggerezza visiva e durabilità nel tempo. Grazie alla combinazione di poliresina, fibra di vetro e pietra frantumata, garantisce una struttura solida e resistente. La lavorazione artigianale, con carteggiatura e levigatura manuale, assicura un aspetto raffinato e curato nei dettagli.

MANUTENZIONE

Per la pulizia quotidiana, utilizzare un detergente liquido neutro o un sapone delicato con acqua, applicando con una spazzola a setole morbide e movimenti delicati per preservare il sigillante. Evitare detergenti a base di agrumi, solventi aggressivi, candeggina, ammoniaca o prodotti industriali.

Il fiberstone può danneggiarsi se esposto a acqua stagnante o fango in caso di temperature sotto lo zero. In aree soggette a gelate prolungate, si consiglia di coprire o riporre i prodotti al chiuso durante l'inverno.

Con la giusta cura, il fiberstone mantiene inalterate le sue caratteristiche estetiche e strutturali nel tempo, offrendo qualità e longevità.

TERRACOTTA



CIOCCOLATO

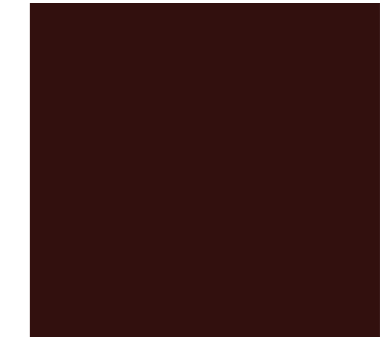

STONE



DOVE



CEMENTO



Stores and info

ITALY

MILANO

Via Pontaccio, 9
20121 Milano
Tel. +39 02 72094197

GENOVA

Via XII Ottobre, 94/R
16121 Genova
Tel. +39 010 2759165

TORINO

Corso Marche, 36
10146 Torino
Tel. +39 011 4240098

VITERBO

S. S. Ortana, km 14,500
01038 Soriano nel Cimino
Tel. +39 0761 7581

SPAIN

MADRID

Calle Padilla, 30
28006 Madrid
Tel. +34 91 659 26 20

FRANCE

PARIS

212 boulevard Saint Germain
75007 Paris
Tel. +33 1 55 35 00 42

CANNES

Palace Center 1, Z.I. des Tourrades
06210 Mandelieu
Tél. +33 (0) 4 92 19 57 77

MARSEILLE

286, Avenue du Millet, Z.I. Les Paluds
13400 Aubagne
Tél. +33 (0) 4 42 18 60 80

GERMANY

MÜNCHEN

Sendlinger Str. 10 - Hofstatt Passage
80331 München
Tel. +49 (0) 89 - 512 666 800

ORDERS PROJECTS AND ESTIMATES

ufficiotecnico@unopiu.it
T +39 0761 758 888
lun-ven 10-13 / 15-19 / sab 10-19

CONTRACT

T +39 0761 758986
contract.hq@unopiu.it

CUSTOMER SERVICE

T +39 0761 758 111
assistenza.clienti@unopiu.it
customer.service@unopiu.co.uk - ENG
kundenservice@unopiu.de - DE
service.apresvente@unopiu.fr - FR
postventa@unopiu.es - ES

ORDERS

ordini@unopiu.it - IT
order@unopiu.co.uk - ENG
estero@unopiu.it - EU / WORLD - UK - AT - CH
pedidos@unopiu.es - ES
info@unopiu.fr - FR
info@unopiu.de - DE

www.unopiu.com

ECOLIGHT

Unopiù, sensitive and attentive to the protection of the environment, complies with the European RoHS/WEEE standard. It is part of the ECOLIGHT consortium that provides for the collection and the disposal of end-of-life products according to strictly ecological standards.

FACEBOOK

facebook.com/unopiu/

INSTAGRAM

instagram.com/unopiu.official/

E condividi le tue foto con l'hashtag
#unopiu



The mark of
responsible forestry

FSC™ C201162

Unopiù is an FSC™ Forest Stewardship Council™ certified company, guaranteeing the quality of the materials used and respect for nature. Certificate TUEV-COC-002147



—
Project:
YellowPark

Photos by:
Mattia Aquila
Fabrizio Bergamo
Adriano Brusaferrì
Francesco Caredda
Giulio Ghirardi
Mattia Greggi
Mauro Mattioli
Thomas Pagani
Alberto Strada
Pierrick Verny
Gionata Xerra

Printed:
November 2025

Unopiù S.p.A

Headquarters
S.S. Ortana Km. 14,5
01038 Soriano nel Cimino (VT)

Registered Office
Via Pontaccio, 9
20121 Milano

info@unopiu.it
marketing@unopiu.it

unopiu.com

